



THAT'S  S LITE

The main headline features the words 'THAT'S' and 'LITE' in large, bold, black, sans-serif capital letters. The word 'S' is significantly larger and colored red. In the center, where the 'S' would normally be, is a black and red LaCimbali S-Lite coffee machine. The machine's top panel has 'LA-CIMBALI S-Lite' printed on it in red and white. The machine is a compact, modern design with a glass front and a red base.

LA-CIMBALI / S-Lite

EN

THAT'S S LITE

04 LACIMBALI S-LITE

06 PRODUCT FEATURES

12 SEGMENTS

18 DIGITAL SOLUTIONS

24 TECHNICAL SHEETS

LA CIBALI S-Lite

COMPACT AND PERFORMANT

In the bustling world of small businesses, every inch of space counts. Every piece of equipment must justify its place. That's why we've created the smallest LaCimbali machine ever.

Meet S-Lite. Designed for those who need a compact product without compromising on the in-cup coffee quality.

S-Lite is perfect for anyone looking for a coffee machine that guarantees quick performance, ease of use, and easy maintenance.

FITS

RIGHT IN



PRODUCT FEATURES

INNOVATIVE FAMILY FEELING

NEW DESIGN

LaCimbali S-Lite introduces an all-new compact design that effortlessly blends into any setting.

Despite its smaller size, it carries the distinctive LaCimbali essence, aligning it with the rest of the S-Line family.

A distinctive and customizable LED light wraps S-Lite's display, reflecting every space's mood in style. Extremely compact sizes allowed by the integrated hopper, which perfectly sits within S-Lite's body, allowing it to snug into every room. A perfect balance between tradition and modernity, combining the classic LaCimbali aesthetic with a fresh, compact form.

S-Lite proves that great things indeed come in small packages.



TASTE ON THE BIG SCREEN

10.1" TOUCHSCREEN DISPLAY

S-Lite comes with a 10.1" touchscreen display, making it incredibly user-friendly. It's all about simplicity and efficiency, allowing every user to have an intuitive user experience, whether the coffee is for them or their clients.

The large display ensures that all the necessary information is easily visible, and the intuitive interface makes it easy even for beginners to brew a perfect cup of coffee.

READY WHEN YOU ARE

PLUG & PLAY

S-Lite is a Plug & Play machine, meaning there's no need for a direct water supply or an expert specialist setting it up. Just plug it in, and you're ready to start serving great coffee. The Plug & Play nature makes S-Lite the ideal choice for businesses that require a quick and easy solution for their coffee needs. With S-Lite, superior coffee is closer than ever.



MAKE IT YOURS

CUSTOMIZABLE INTERFACE

S-Lite's flexible UI allows you to personalize it to suit your and your business' preferences, making it the best device to showcase your identity. Tweak its logo, screen-saver, in-brew loading screens and icons. Designed to adapt to your needs, it provides a seamless coffee-making experience. Whether you prefer a minimalist design or want to have all the features at your fingertips, S-Lite allows you to customize the interface to your liking.



STAY CONNECTED

INTEGRATED WI-FI AND USB

S-Lite is equipped with integrated Wi-Fi and USB, adding a layer of convenience and connectivity. This "always online" feature means S-Lite smooth coffee-making can get even smoother. Whether you need to update the software or want to download the latest coffee recipes, the integrated Wi-Fi and USB make it easy.





EFFORTLESS CLEANING

AUTOMATIC WASHING SYSTEM

S-Lite features the same convenient cleaning technology as the biggest members of the S-line family. Thanks to the Automatic Washing System, you can save time and ensure your machine is always ready to deliver the perfect cup of coffee. It's about making your life easier, one less worry at a time. With AWS, you can be sure that your machine is always in the best condition, without the hassle of dedicated cleaning staff. **For an even higher grade of cleanliness, choose LaCimbali cleaning products, designed to thoroughly look after your machine.**

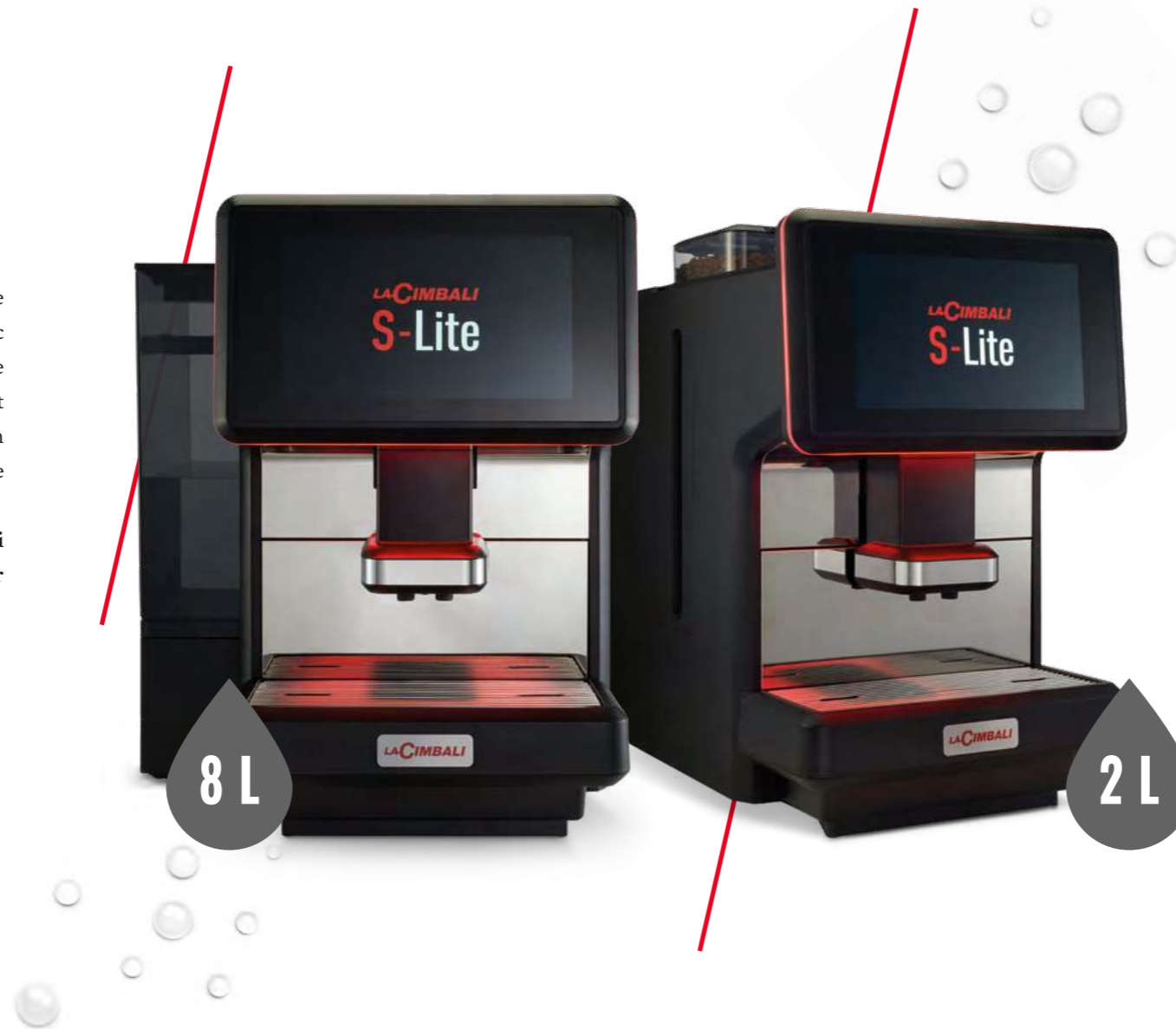

FLEXIBLE TO YOUR NEEDS

WATER TANK OPTIONS

Flexibility is key with S-Lite, that's why it comes in two versions to cater to your specific needs. Choose between a 2-litre water tank for smaller operations or an 8-litre version for busier environments. This ensures you can serve your customers without any interruptions, regardless of your business' size. Whether you have a small office or a bustling restaurant, S-Lite's water tank options provide the convenience you need to keep your business running smoothly. Need a constant water flow? S-Lite comes with a water supply connection kit, ensuring non-stop refill.

THE OFFICE ENERGIZER

OFFICES

Meet your office's own barista. With its compact size and user-friendly features, S-Lite is the perfect addition to any office environment. It fits seamlessly into any break room or kitchenette. Moreover, depending on your team's dimension, the two water tank versions ensure that there's always enough coffee to fuel their productivity. Plus, with AWS and easy maintenance, you can keep your focus on your work, not on your coffee machine. Boost morale, foster collaboration, and keep your team energized throughout the day.



THE
OFFICE
ENERGIZER



THE
PERFECT
BUSINESS
PARTNER

THE PERFECT BUSINESS PARTNER

BUSINESSES

For small businesses, every square foot and every piece of equipment counts.

That's where S-Lite comes in. Its compact size makes it perfect for small spaces, while its advanced features ensure it delivers big performance.

Whether you're running a boutique, a salon, or a small retail store, S-Lite can enhance your customer experience by providing high-quality coffee on demand.

Plus, being Plug & Play, setting up S-Lite is as easy as 1-2-3.



ELEVATE YOUR GUEST EXPERIENCE

HOTELS

In the hospitality industry, small touches make a big difference. S-Lite can help small hotels elevate their guest experience by providing high-quality coffee at any time of the day. Its compact size makes it perfect for breakfast areas and lobbies, while its user-friendly features ensure that anyone can make a perfect cup of coffee. With S-Lite, you take up a notch your coffee offer and make your guests' stay even more memorable.



CONVENIENCE AT ITS BEST

CONVENIENCE STORE & PETROL STATION

In a convenience store or a petrol station, speed and efficiency are key. S-Lite is designed with these needs in mind. Its fast brewing time and easy-to-use interface allow you to serve your customers quickly, while its coffee can turn a quick stop into a joyful experience.

S-Lite can also handle the high-traffic environment of a convenience store or petrol station with ease, thanks to its durable design and easy maintenance.

DINING DELIGHT

SMALL BISTROS & RESTAURANTS

Small sizes but big results, S-Lite understands the needs of small food venues like bistros and restaurants. Its compact design fits effortlessly into intimate dining spaces, or behind the counter, complementing your culinary offerings. With the Plug & Play feature, S-Lite is ready to serve without fuss, allowing you to focus on crafting memorable dining experiences.



ART.IN.COFFEE

DATA CONTROL, STREAMLINED

LaCimbali supports every business with dedicated solutions, easing parts of the workload and facilitating the consultation and management of others. Art.In.Coffee backs every business up by offering advanced data processing, allowing the owner to remotely check beverage consumption.

More than data analysis: the bidirectional telemetry available on LaCimbali fully automatic machines allows for remote intervention, streamlining the whole process*. With Art.In.Coffee, you can slim operations down, enhance user experience, and facilitate business decision-making.

Art.In.Coffee supports the integration with other data collection and visualization systems through API access.

*Available from Q1 2024



GLOBAL REMOTE SERVICE PROGRAM*

WE HAVE THE SOLUTION. WHEREVER YOU ARE, WHENEVER YOU NEED IT, WHATEVER THE ISSUE.

Business service has never been easier thanks to our **Global Remote Service Program**. LaCimballi's technical experts and service partners can access the machine's user interface remotely like they're right next to it. This allows them to monitor machine operations, access configurations for changing settings, view diagnostic archives, and update the software. By doing so, problems can be diagnosed and fixed, reducing travel costs by 15% and optimizing technician labor time on-site by 20%.

Remote Control: in case of malfunctioning, ours or our partners' tech experts can make any necessary adjustments remotely.

Quicker On-Site Intervention: in case of mechanical issues detected, the remote overview can provide all relevant information to the technician, saving them a great deal of time.

*Sold separately, subscription required

GLOBAL REMOTE SERVICE PROGRAM

SERVICE



UX LIKE NO OTHERS

Create and manufacture formidable machines, and make them as easy to use as possible: this is LaCimbali's goal and the reason we've developed innovative apps to take every user through a pleasant and seamless experience.

CASHLESS PAYMENT SYSTEMS

S-Lite is ready to be paired with MDB protocols-equipped cashless payment systems. With them, everyone can pay comfortably and safely using their credit card or smartphone, without having to use hard cash. This modern convenience not only streamlines the payment process but also facilitates a smoother, quicker service, enhancing the overall customer experience



CUP4YOU

Experience a more flexible and personal way to pair your S-Lite and manage orders, without the constraint of a unified Wi-Fi network. Cup4You allows you to control multiple machines at once, managing all of the most important features remotely. It also brings new layers of convenience and customer fidelity aid:

- **Users management:** set and manage different users

within your network, from staff to guests, giving them access to specific areas and functionalities.

- **Credit tab:** hand a set amount of credit to a user, allowing

them to make use of the machine for free during a defined amount of time or for a number of uses.

Cup4You's API package is also available to develop an autonomous digital solution able to communicate with LaCimbali machines.

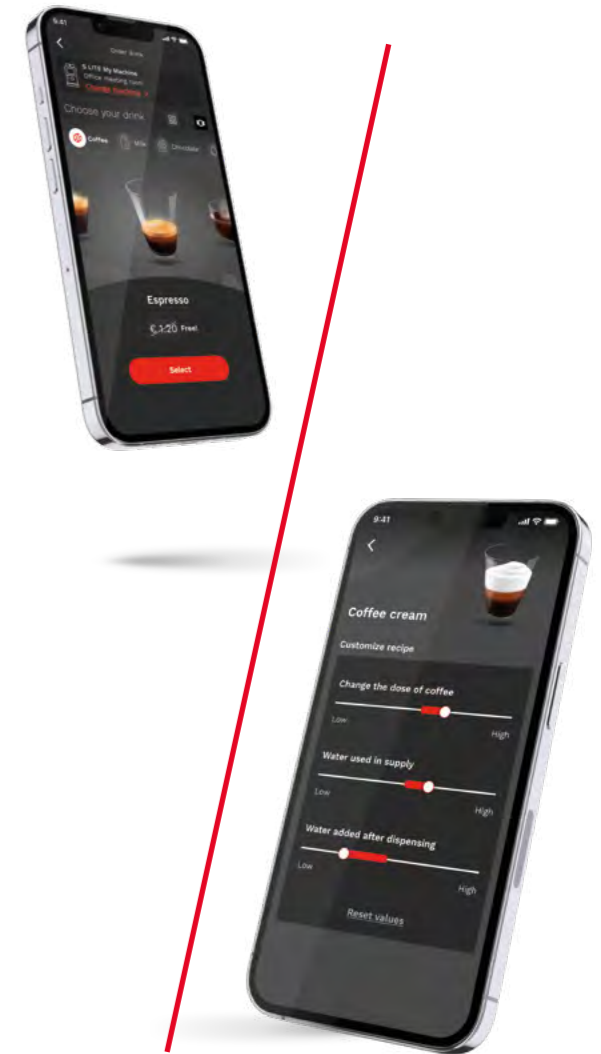

DIMENSIONS

Width x Depth x Height	320 x 512 x 535 mm (2 L) 420 x 512 x 535 mm (8 L)
------------------------	--

Weight	19 kg (2 L) - 20,5 kg (8 L)
--------	-----------------------------

CONNECTIONS

Power supply	220-240V / 120 V / 100 V
--------------	--------------------------

Power	2900 W
-------	--------

Connection to the water main	Optional
------------------------------	----------

Water tank inside	Double solution: 2 L - 8 L
-------------------	----------------------------

CAPACITY

Recommended cups/day	Up to 80
----------------------	----------

HOPPERS

Coffee bean hopper	750 g
--------------------	-------

FEATURES

Added water	Yes
-------------	-----

Control panel	10,1" Touch Screen Display
---------------	----------------------------

Number of selections	Up to 24	1x4 3x6 3x7
----------------------	----------	-----------------

Coffee spout height (from/to)	85 / 175 mm
-------------------------------	-------------

Water Pump	Vibration pump
------------	----------------

Grounds container capacity	45 pieces (10 g / piece)
----------------------------	--------------------------

Drip tray	1,7 L approx.
-----------	---------------

THERMAL SYSTEM

Thermoblock	
-------------	--

GRINDERS

Number of grinders	1
--------------------	---

Blades	Ceramic
--------	---------

DEK

Grounded dek inlet	Yes
--------------------	-----

COFFEE GROUP

Coffee group type	Plastic
-------------------	---------

Min / max dose	Up to 16 g
----------------	------------

Coffee washing cycle (type)	Automatic (tablets)
-----------------------------	---------------------

MILK SYSTEM

Milk suction system	Venturi System
---------------------	----------------

Milk washing cycle	Automatic
--------------------	-----------

INTERFACE

Payment system (equipped with MDB Protocol)	Optional
--	----------

USB	Yes
-----	-----

Telemetry/Wi-Fi	Yes
-----------------	-----

PERFORMANCE

Espresso (cups/hour) (50 ml)	80 cups
------------------------------	---------

Americano (cups/hour) (240 ml)	75 cups
--------------------------------	---------

Cappuccino (cups/hour) (200 ml)	65 cups
---------------------------------	---------

Hot water (litres/h - delivery of 500 cc)	30 L
---	------

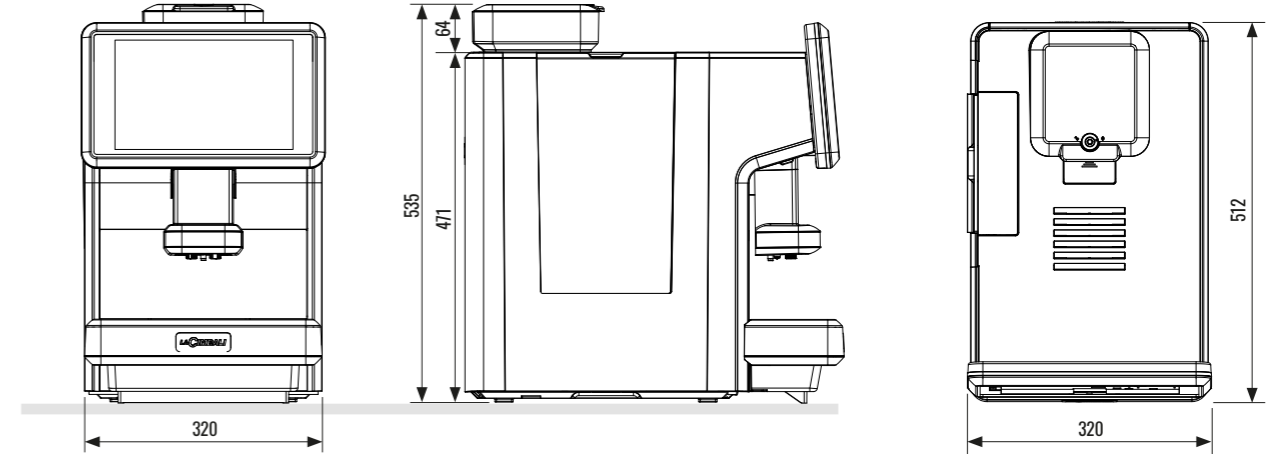
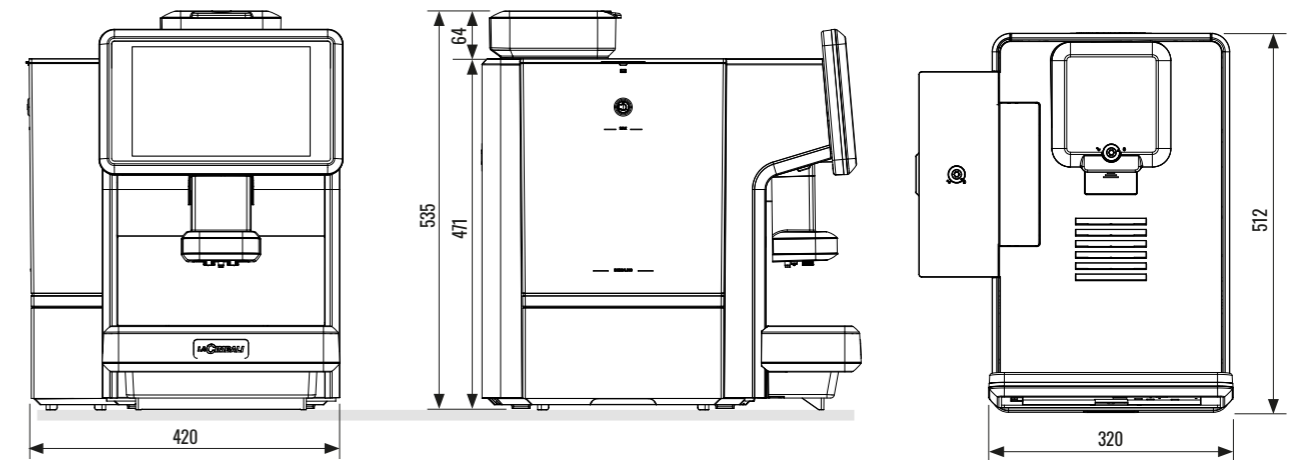
2L**8L**

Take a peek in AR by scanning the QR Code



or discover it with LaCimbali Project App

LA-CIMBALI



Specialty Beverage Solutions

7519 Flint Road SE, Calgary, AB T2H1G3

www.sbsolutions.ca | Tel: 1-888-805-5528 | Email: sales@sbsolutions.ca