



MODELS

KGL-OF-(40, 50, 60)-S

KGL-OF-(40, 50, 60)-R

**GRAB-N-GO
LOW PROFILE CASE**

CASE HOLDS 36°F TO 40°F • FORCED AIR REFRIGERATION • OPEN FRONT
FRONT LOADING • LED LIGHTING IN CANOPY AND UNDER ALL SHELVES
PULL DOWN NIGHT CURTAIN • CASES CAN BE MULTIPLEXED



Intertek



Intertek



AUTODESK®
REVIT®

| SELF CONTAINED | Model | O.A. Length (inches) | Volume FT ³ | Electrical 115 Volts | | | | | NEMA 115 V Plug | Weight lbs | | Crate Size (inches) | | | |
|----------------|-------------|----------------------|------------------------|----------------------|------------|-------|-------------|----------|-----------------|------------|----------|---------------------|------|------|----|
| | | | | Front | Compressor | | LIGHTS Fans | EVAP Pan | | Total Amps | No Crate | With Crate | L" | W" | H" |
| | | | | | H.P | F.L.A | | | | | | | | | |
| | KGL-OF-40-S | 41 | 12.98 | 5/8 | 8.9 | 0.85 | 6.7 | 16.42 | 5-20P | 357 | 507 | 43.8 | 34.5 | 67.8 | |
| | KGL-OF-50-S | 50.2 | 16.21 | 3/4 | 16 | 1.33 | 6.7 | 24.00 | - | 394 | 569 | 53 | 34.5 | 67.8 | |
| | KGL-OF-60-S | 60.6 | 19.85 | 3/4 | 16 | 1.39 | 6.7 | 24.06 | - | 454 | 653 | 63.5 | 34.5 | 67.8 | |

| REMOTE | Model | O.A. Length (inches) | 115 Volts Total Amps | B.T.U | Weight lbs | |
|--------|-------------|----------------------|----------------------|-------|------------|------------|
| | | | | | No Crate | With Crate |
| | | | | | | |
| | KGL-OF-50-R | 50.2 | 0.43 | 4897 | 317 | 491 |
| | KGL-OF-60-R | 60.6 | 0.49 | 5141 | 376 | 575 |

STANDARD FEATURES

- Silver colored PVC coated steel front panel
- CFC free injected foam insulation
- PVC coated steel gray interior
- Black steel kick plate
- Foamed polystyrene black end panels
- Tempered side glass
- Height adjustable shelves can be tilted
- Products stop on shelves
- Temperature and defrost regulated by a digital controller
- Digital thermometer
- Slide out condensing unit on self-contained units
- Removable condensate evaporating pan for easy cleaning on self contained units
- Cord and plug KGL-OF-40S only
- Levelling feet

OPTIONAL FEATURES

- Stainless steel exterior and / or interior
- Other colors available
- Additional shelves
- Price tag molding
- Joining kit
- Partition or product dividers
- Condensate evaporating pan for remote cases
- Casters-add 4-3/8" to height
- Stainless steel legs are adjustable from 5-1/8" to 7-5/8"

WARRANTY

One year parts and labor with an additional four years on the compressor (part only)

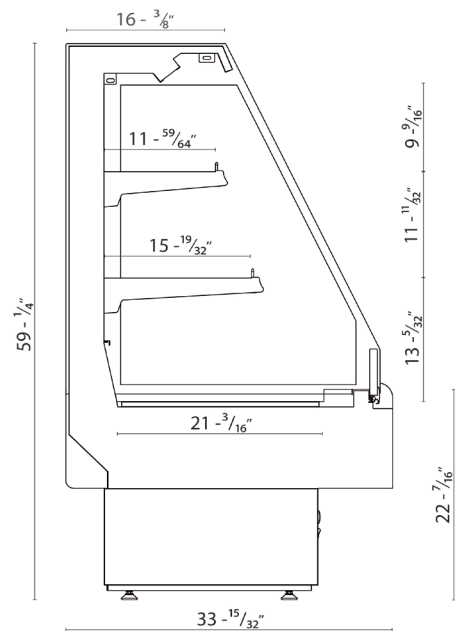

Standard Mounting



Levelling Feet

Optional Mounting





Adjustable Legs

Casters

NOTE

These cases are engineered to operate in locations not exceeding 75°F and 55% R.H. These cases are designed to operate using R404a refrigerant. Alternate refrigerants available by special order. O.A. length includes (2) ends at 1-1/2" each. Ventilation grills at front and back cannot be blocked. B.T.U.'s are calculated at 14°F (evaporator) and 90°F (ambient). Remote cases are provided with an expansion valve and a liquid solenoid for pump down cycle. On remote cases, if no floor drain is provided, a condensate evaporating pan must be ordered and 6.7 amps added to the amp load. Remote cases must be hard wired - no plugs.

 Tel: 786.600.4687 / Toll Free: 844.218.8477
Fax: 786.661.4100

 Tel: 514.737.9701 / Toll Free: 888.275.4538
Fax: 514.342.3854 / toll free: 877.453.8832

06/2017 sales@mvpgroupcorp.com / mvpgroupcorp.com



Hydra - Kool is a registered trademark of MVP Group Corp.
SPECIFICATIONS SUBJECT TO CHANGE WITHOUT NOTICE