



# KM-301B\_J

## SELF-CONTAINED CUBER WITH BUILT-IN STORAGE BIN



KM-301B\_J  
07/24/19  
Item # 13550

Item #: \_\_\_\_\_  
Project: \_\_\_\_\_  
Qty: \_\_\_\_\_  
AIA#: \_\_\_\_\_

**W x D x H**  
**30" x 28" x 39"\***  
\*including 6" legs

ADA Compliant

**KM Edge DESIGN**

**KM-301BAJ**  
Air-Cooled  
Shown

**KM-301BWJ**  
Water-Cooled



## Features

- ▶ Individual crescent cube
- ▶ Stainless steel evaporator
- ▶ CycleSaver™ design

- Up to 290 lbs. of ice production per 24 hours
- Built-in storage capacity of 3.3ft<sup>3</sup>/100 lbs.
- Durable stainless steel exterior
- Front-in, front-out airflow
- Removable air filter (air-cooled model only)
- Ice bin opening is ADA compliant
- 6.5 ft. (2000 mm) power cord with NEMA 5-15P plug
- EverCheck™ alert system
- R-404A Refrigerant

### Warranty:

3 Year Parts & Labor on entire machine. 5 Year Parts & Labor on Evaporator. 5 Year Parts on Compressor; air-cooled condenser coil. Valid in United States, Canada, Puerto Rico and U.S. Territories. Contact factory for warranty in other countries.

Shipping: (LxWxH) 34" x 33" X 39" Volume: 25.32ft<sup>3</sup>



Condenser	Model	ICE PRODUCTION		WATER USAGE		ELECTRICAL			Heat Rejection BTU/hr.	Refrigerant Charge Amount	Net / Ship Weight (lbs.)	
		Air / Water Temp Lbs. per 24 hours 70°/50°F	90°/70°F	Potable Gal. per 100 lbs. 90°/70°F	Condenser Gal. per 100 lbs. 90°/70°F	kWh Used per 100 lbs. 90°/70°F	Max. Fuse Size or HACR Circuit Breaker	Amperage				Voltage
Air-Cooled	KM-301BAJ	290	212	22.0	N/A	7.1	15A	8.4A	115V/60/1	4,200	13.4 oz.	171 / 206
Water-Cooled	KM-301BWJ	285	237	20.0	92	4.9	15A	5.7A	115V/60/1	4,050	12.3 oz.	154 / 189

Power cord included

### KM Edge Cube Dimensions\*

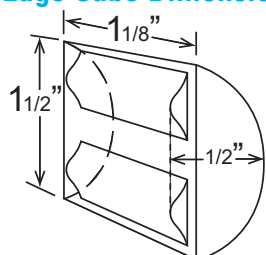

\* approximate size in inches, image not to scale

### Operating Limits

- Ambient Temp Range 45 - 100°F
- Water Temp Range 45 - 90°F
- Water Pressure 10 - 113 PSIG
- Voltage Range 104 - 127V

### Service

- Allow enough space at rear for water supply and drain connections. Allow at least 2" (5 cm) on right side for proper air circulation and at least 0.6" (15 mm) clearance at top for service/maintenance.

### Plumbing

- Icemaker Water Supply Line: Min. 1/4" Nominal ID Copper Water Tubing or Equivalent
- Icemaker Drain Line: Min. 3/4" Nominal ID Hard Pipe or Equivalent
- Water-Cooled Model (Lines Must Be Independent of Icemaker)
- Condenser Water Supply Line: Minimum 1/4" Nominal ID Copper Water Tubing or Equivalent
- Condenser Drain/Return Line: Min. 1/4" Nominal ID Hard Pipe (open drain system) or Copper Water Tubing (closed loop system) or Equivalent

### Water Filter

Please refer to water filter spec sheet for recommended configurations.

Hoshizaki reserves the right to change specifications without notice.



# KM-301B\_J

## SELF-CONTAINED CUBER WITH BUILT-IN STORAGE BIN



KM-301B\_J  
07/24/19  
Item # 13550

FRONT VIEW

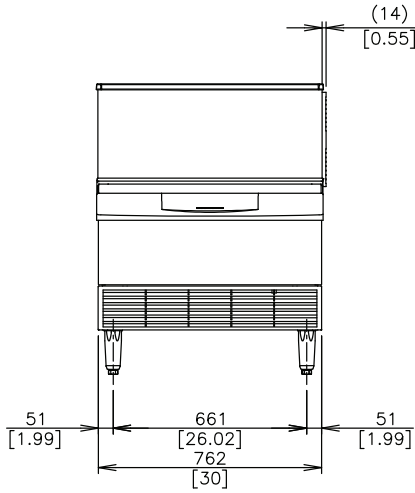

AIR-COOLED

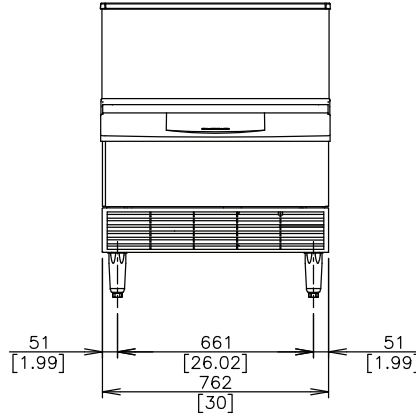

WATER-COOLED

### TOP VIEW

mm  
[inch]

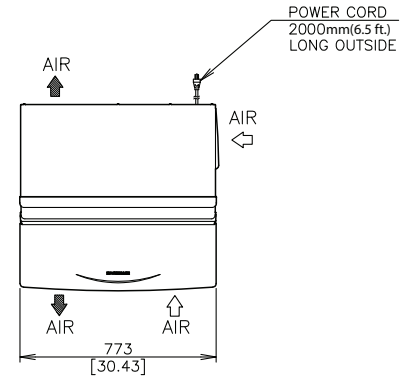

AIR-COOLED

SIDE VIEW

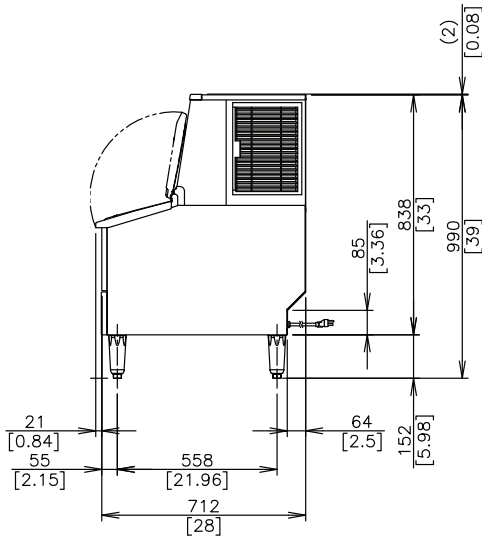

AIR-COOLED

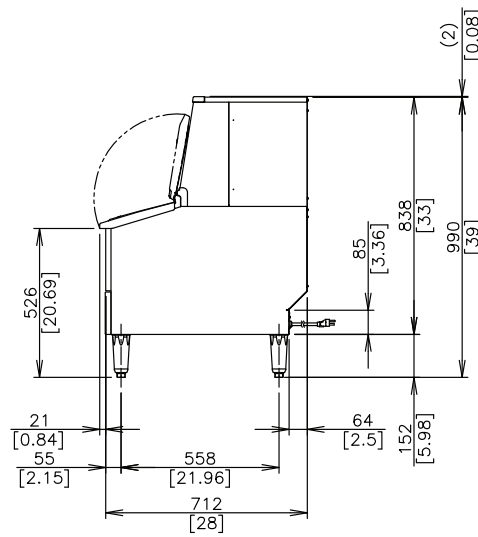

WATER-COOLED

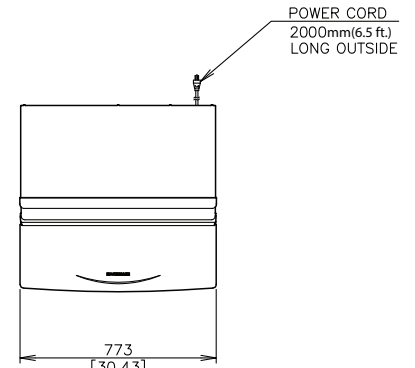

WATER-COOLED

REAR VIEW

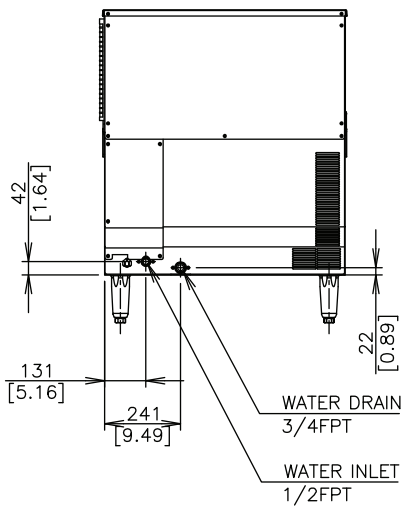

AIR-COOLED

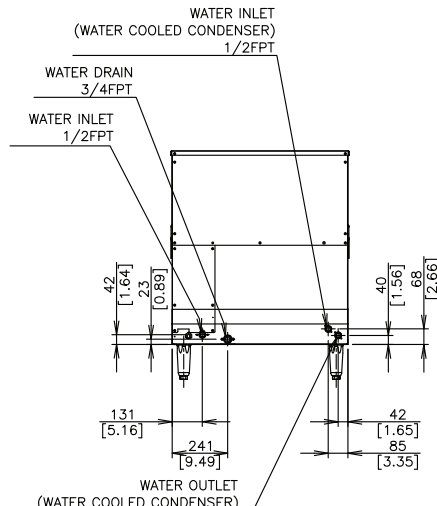

WATER-COOLED