

INSTRUCTIONS



V1401 MIXER

M802 & V1401 MIXERS

MODELS

M802 ML-104687, 104694, 104697, 134085

V1401 ML-104674, 104675, 104685, 104686, 134075



701 S. RIDGE AVENUE
TROY, OHIO 45374-0001

937 332-3000

www.hobartcorp.com

FORM 33785 Rev. C (Aug. 2003)



Model M802 Mixer



Model V1401 Mixer

Installation, Operation and Care of M802 and V1401 MIXERS

SAVE THESE INSTRUCTIONS

GENERAL

The M802 model mixer is a heavy-duty 80-quart mixer with a 3 horsepower motor and an electro-mechanical timer as standard equipment. Other standard features include a clutch and a power bowl lift. With the use of bowl adapters and special agitators, 30-, 40-, or 60- quart bowls may be used on the M802. This mixer is also available with a 14" higher than standard pedestal.

The V1401 model mixer is a heavy-duty 140-quart mixer with a 5 horsepower motor and an electro-mechanical timer as standard equipment. Other standard features include a clutch and a power bowl lift. With the use of bowl adapters and special agitators, 30-, 40-, 60-, 80-, or 100- quart bowls may be used on the V1401. This mixer is also available with a 17" higher than standard pedestal.

The Bowl Guard is standard equipment on all M802 and V1401 models.

A Programmable Timer Controller is optional on M802 and V1401 models.

These mixers can be ordered with deluxe finish, which includes a chrome-plated transmission case, base, bowl support, and pedestal.

A variety of attachments and accessories are available for all mixers. These are described in a separate *Use and Applications Handbook* which is furnished with each mixer.

INSTALLATION

UNPACKING

Immediately after unpacking the mixer, check for possible shipping damage. If this machine is found to be damaged after unpacking, save the packaging material and contact the carrier within 15 days of delivery.

Prior to installation, test the electrical service to assure that it agrees with the specifications on the machine data plate.

LOCATION

Place the mixer in its operating location. There should be adequate space around the mixer for the user to operate the controls and install and remove bowls. The area above the mixer should allow the top cover to be removed for routine maintenance and servicing.

Holes are provided in the base for permanent bolting to the floor, although this is not necessary in normal installations. Four plastic plugs are supplied with the mixer to plug these holes if they are not used.

Once located, the mixer must be leveled.

Remove the top cover screws and the top cover.

Place a level on the machined surface of the transmission case (Fig. 1) and slide shims under the legs (base) of the mixer as required to level it front-to-back and side-to-side.

Do not replace the top cover until installation is completed.

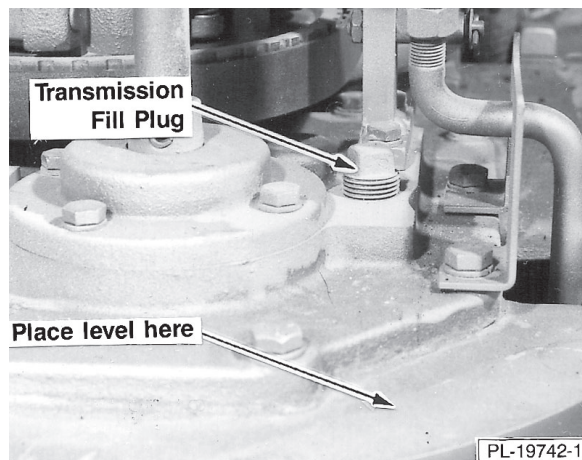

Fig. 1

Check Lubrication Before Use

This mixer is shipped with oil in the transmission and planetary. Check oil levels before starting mixer. Refer to LUBRICATION, pages 13 – 14, for applicable lubrication procedures.

ELECTRICAL CONNECTIONS

WARNING: ELECTRICAL AND GROUNDING CONNECTIONS MUST COMPLY WITH THE APPLICABLE PORTION OF THE NATIONAL ELECTRICAL CODE AND/OR OTHER LOCAL ELECTRICAL CODES.

WARNING: DISCONNECT ELECTRICAL POWER SUPPLY AND PLACE A TAG AT THE DISCONNECT SWITCH INDICATING THAT YOU ARE WORKING ON THE CIRCUIT.

A threaded hole for $\frac{3}{4}$ " trade size conduit is located at the top of the pedestal. Make electrical connections per the wiring diagram located on the inside of the Top Cover.

Check Rotation (Three-Phase Machines Only)

Three-phase machines must be connected so the planetary rotates in the direction of the arrow on the Drip Cup. To check rotation:

Set the gear shift lever on 1.

Apply power to the mixer, set the Electro-Mechanical Timer on HOLD; or, if equipped with a Programmable Timer Controller, set it on [-- : --]. Place the Bowl Support all the way up. Set the speed on 1. Position the clutch on RUN. Momentarily run the machine by pushing the START button and then the STOP button.

If rotation is incorrect, DISCONNECT ELECTRICAL POWER SUPPLY and interchange any two of the incoming power supply leads.

OPERATION

WARNING: MOVING BEATER IN BOWL, KEEP HANDS, CLOTHING, AND UTENSILS OUT WHILE IN OPERATION. DO NOT USE WITHOUT INTERLOCKED GUARD.

Every M802 and V1401 mixer is equipped with either Electro-Mechanical Timer Control (described on this page) or a Programmable Timer Controller (described on pages 7 – 9). Also, become familiar with the other operating parts (Fig. 2) and their functions, which are referenced throughout the OPERATION section (pages 6 – 12).

The Bowl Guard must be in position or the mixer will not operate. Refer to page 11.

If the Bowl Support is not all the way up, the mixer will not operate unless the START button is held in.

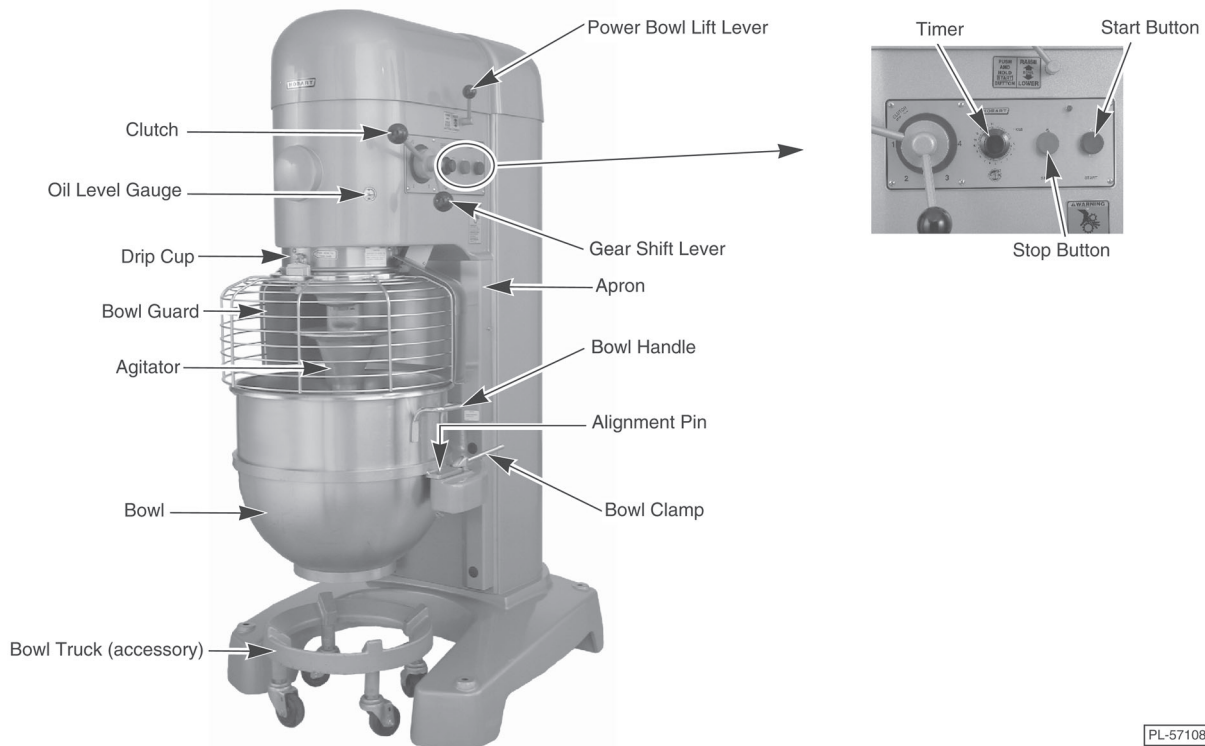

Fig. 2

ELECTRO-MECHANICAL TIMER CONTROLS (when equipped)

The START button is used to start the mixer.

The STOP button is used to stop the mixer.

The TIMER is used in conjunction with the START button for timed mixing operations and will stop the mixer when a preset time has elapsed.

For timed mixing — Place the clutch lever on STOP and set the gear shift lever at the desired speed. Set the timer at the desired time and press the START button to start the motor. Move the clutch lever to RUN to start mixing. (Clutch Lever and Gear Shift Lever are described on page 10.)

If you need to stop the mixer before the time has elapsed, move the clutch lever to STOP and press the STOP button. To resume mixing, press the START button and move the clutch lever to RUN.

For non-timed mixing — Place the clutch on STOP and set the gear shift lever at the desired speed. Set the timer on HOLD, press the START button to start the motor, and move the clutch lever to RUN to start mixing. To stop the mixer, move the clutch lever to STOP and press the STOP button.

PROGRAMMABLE TIMER CONTROLLER (when equipped)

At Idle, the timer display [-- : --] shows that no time has been set (Fig. 3).

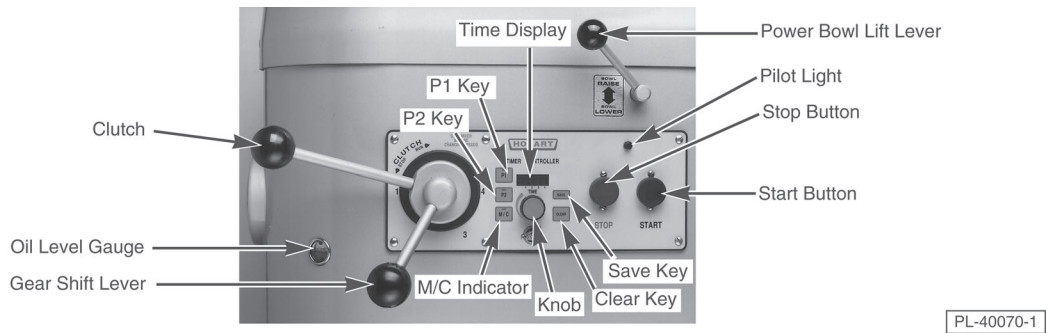

Fig. 3

Timer Keys	Programming Function (if the mixer is not mixing).
P1	Contains up to four preset times. Displays each preset time sequentially.
P2	Contains up to four additional preset times. Displays each preset time sequentially.
Knob	Changes the time as indicated by the display.
Save	Replaces the preset time with the indicated time.
Clear	Returns to Idle from a programming function.

For Continuous Mixing

START and STOP buttons control mixing operation.

Beginning from the Idle display [-- : --], press START to begin mixing. The M/C indicator will be lit and the total mixing time will be indicated (minutes and seconds).

Press STOP when mixing is done; the M/C indicator light goes off and the Idle display [-- : --] returns.

Using the Dial Timer to Set the Mixing Time

Beginning from the Idle display [-- : --], turn the KNOB to set the mixing time. The M/C indicator will be lit.

START and STOP buttons control mixing operation.

Press START to begin mixing. The timer will count down from the set time to [00 : 00].

If STOP is pressed, both mixing and timer countdown will be interrupted. After pressing STOP, press START to resume both mixing and timer countdown, or press CLEAR to return to the Idle display.

When the timer reaches [00 : 00] the mixer stops, the M/C indicator goes off, a beep tone sounds for two seconds and the Idle display [-- : --] returns.

PROGRAMMABLE TIMER CONTROLLER (when equipped) continued

Using the Preset Keys, P1 or P2, to Set the Mixing Time

Each preset key has four time settings. The indicator above the number 1, 2, 3 or 4 and the P1 or P2 indicator light identify which preset time is being displayed. The chart below shows the default settings; the next page shows how to revise these preset times. The Dial Timer KNOB can be used to adjust the mixing time if the knob is turned prior to pressing START.

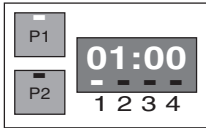

□ Indicators above P1 and 1 indicate the first preset time contained in P1.

Beginning from the Idle display [-- : --], press P1 or P2 to display the #1 preset mixing time. (Pressing P1 or P2 again will display the next preset time, etc.)

* The Dial Timer KNOB can adjust the time.

START and STOP buttons control mixing operation.

Press START to begin mixing. The timer will count down from the set time to [00 : 00].

If STOP is pressed, both mixing and timer countdown will be interrupted. After pressing STOP, press START to resume both mixing and timer countdown, or press CLEAR to return to the Idle display.

When the mixer is stopped, you may perform any appropriate task, such as the following: Add ingredients, change speed, reset the timer, continue mixing or unload.

When the timer reaches [00 : 00] the mixer stops, a beep tone sounds for two seconds and the next preset mixing time displays. When the last preset time reaches [00 : 00] the P1 or P2 indicator goes off and the Idle display [-- : --] returns. Repeat from * to complete four preset times.

The timer reverts to the Factory Programmed Preset Times after any power interruption:

Factory Programmed Preset Times

Preset Key	Indicator			
	1	2	3	4
P1	01:00	02:00	10:00	00:00
P2	02:00	01:00	05:00	03:00

PROGRAMMABLE TIMER CONTROLLER (when equipped) continued

To Revise the Preset Mixing Times Contained in P1 or P2

Each preset key has four preset time settings. The indicator above the number 1, 2, 3 or 4 and the P1 or P2 indicator light identify which preset time is being displayed.

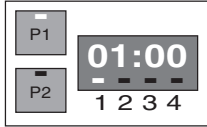

□ Indicators above P1 and 1 indicate the first preset time contained in P1.

Beginning from the Idle display [-- : --], press P1 or P2 to display the #1 preset mixing time. (Pressing P1 or P2 again will display the next preset time, etc.)

+ Turn the KNOB to change the time for the indicated preset.

- Press SAVE to retain the revised time and move to the next preset time.

Repeat from + for each preset time (1, 2, 3 and 4 contained in P1 or P2).

Pressing CLEAR will retain the saved times and return to the Idle display [-- : --].

The timer reverts to the Factory Programmed Preset Times after any power interruption:

Factory Programmed Preset Times

Preset Key	Indicator			
	1	2	3	4
P1	01:00	02:00	10:00	00:00
P2	02:00	01:00	05:00	03:00

CHANGING SPEEDS

The Clutch Lever is used when changing speeds. Moving the Clutch Lever to STOP disengages the clutch and activates a brake which stops the planetary. The motor will continue to run with the Clutch Lever on STOP unless the STOP button is pressed.

The Gear Shift Lever is used to change speeds. To change speeds, disengage the clutch by moving the Clutch Lever to STOP. The brake is automatically actuated. When the agitator shaft has stopped, move the Gear Shift Lever to the desired speed. Make sure the Gear Shift Lever lines up with the number on the shifter plate — **never position the handle between numbers**. Place the Clutch Lever on RUN to continue operation.

POWER BOWL LIFT

CAUTION: Before lowering the bowl onto a bowl truck, always unlock both bowl clamps.

The Power Bowl Lift Lever is used to raise or lower the bowl while the motor is running. The Wire Cage Assembly must be in the front-center position. If the Clutch Lever is in the RUN position, the Planetary and Agitator will be mixing at the speed indicated by the position of the Gear Shift Lever (this may be required by recipe or when using the Bowl Scraper Attachment). If the Clutch Lever is on STOP, the Planetary and Agitator will not be mixing. The Electro-Mechanical Timer (if equipped) will allow the mixer to operate if it is on HOLD or if time is set on the timer. The Programmable Timer Controller will allow the mixer to operate if it is set to [-- : --] or if time is set on the timer. Press and hold the START button and move the Power Bowl Lift Lever clockwise to raise the bowl or counterclockwise to lower it. An overload slip clutch will ratchet at the top and bottom stop positions to signal end of travel and protect the operating mechanism. **NOTE:** On new machines, the power bowl lift lever may need to be manually returned to the center neutral position until parts are broken-in.

MIXING

This section explains operation of the mixer and how to install bowls, agitators and attachments. A separate *Use and Applications Handbook*, provided with the mixer, contains information on mixing procedures and specific uses for agitators, attachments and accessories.

Bowl

New mixer bowls and agitators (beaters, whips, and dough arms) should be thoroughly washed with hot water and a mild soap solution, rinsed with either a mild soda or vinegar solution, and thoroughly rinsed with clear water BEFORE being used. This cleaning procedure should also be followed for bowls and agitators before whipping egg whites or whole eggs.

The bowl must be installed before the agitator. To install the bowl, fully lower the bowl support. Position the bowl so the alignment bracket on the back of the bowl is under the retainer on the bowl support and the alignment pins on the front of the bowl support fit in the holes in the bowl. Lock the bowl in place by rotating the bowl clamps over the ears of the bowl.

If a bowl adapter is required, install it on the bowl support as you would the bowl and then install the bowl on the adapter.

Agitator

To install an agitator, the bowl must be installed and fully lowered. Place the agitator in the bowl, push it up on the agitator shaft, and turn it clockwise to seat the shaft pin in the slot of the agitator shank.

Bowl Guard (Fig. 4)

The Wire Cage Assembly on the Bowl Guard can be rotated out of the way to add ingredients or access the bowl and agitator. Some ingredients, such as liquids or powders, may be added through the wire cage assembly while the mixer is in operation. An ingredient chute accessory is available to assist in adding ingredients. Contact your local Hobart Sales representative for more information.

To Rotate the Wire Cage Assembly to the Rear

Push the Latch in to release the Centering Pin from the Centering Ramp. Note how the grooves on the nylon Retainers allow the Wire Cage to ride around the circular Ridge on the planetary Drip Cup. The Wire Cage can rotate 360° to the left or right. When the Wire Cage returns to the front-center position, the Centering Pin is captured and held by the Centering Ramp, restricting rotation of the Wire Cage until the Latch is pressed again.

The Wire Cage must be in the front-center position for the mixer to operate.

To Remove the Wire Cage Assembly for Cleaning

Lower the Bowl. Rotate the Wire Cage to the rear. Remove both Agitator and Bowl. Return the Wire Cage to the front.

While holding the Wire Cage securely with both hands, use your thumb to push down on the Black Release Knob. Lower and remove the Wire Cage. Wash it in a sink, rinse with clear water and dry with a clean cloth.

The stainless steel Splash Guard can be wiped off or washed easily with a cloth or sponge and warm soapy water. Rinse with clear water. Dry with a clean cloth.

To Reinstall the Wire Cage Assembly

Hold the Wire Cage so its top ring is positioned around the planetary Drip Cup with the grooves in both nylon Rear Retainers straddling the Ridge on the Drip Cup. Push in the Front-Center Retainer until it stays in and so that its grooves also straddle the Ridge on the Drip Cup. The Wire Cage is properly assembled when all three Retainers straddle the Ridge on the Drip Cup in the three opposed locations.

Rotate the Wire Cage out of the way to install or remove the Agitator and Bowl or to add ingredients.

Return the Wire Cage to its front-center position to operate the mixer.

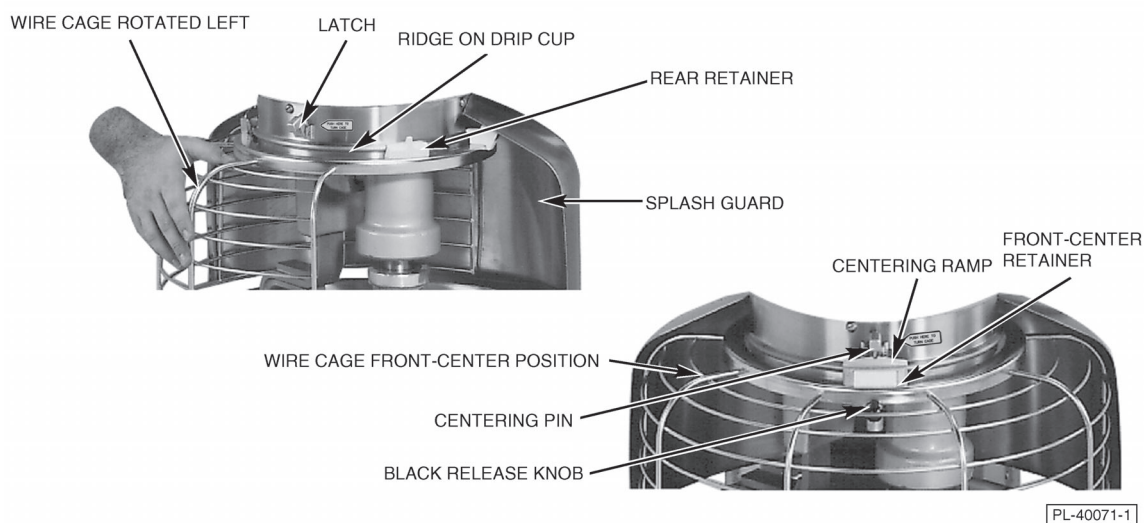

Fig. 4

Attachments (When Mixer is Equipped With Attachment Hub)

ALWAYS place the clutch lever on STOP and press the STOP button before installing or removing attachments.

To install an attachment, loosen the attachment hub thumb screw and remove the plug. Insert the attachment into the attachment hub, making certain that the square shank of the attachment is in the square driver of the mixer. Secure the attachment by tightening the thumb screw.

Move the gear shift lever to the desired speed. Move the clutch handle to RUN. With the bowl support all the way up and the wire cage in the front-center position, start the mixer to operate the attachment.

The meat and food chopper attachment should be operated in second or third speed. If material in the cylinder stalls the mixer, push the STOP button at once. DO NOT attempt to restart the mixer in a lower speed — remove the adjusting ring, knife, plate, and worm and clear any obstruction. THIS ATTACHMENT MUST NOT BE USED TO CHOP BREAD CRUMBS.

NOTE: Attachment hub should not be used while mixing.

Mixer Speeds

Speed 1 (Low) — This speed is for heavy mixtures such as pizza dough, heavy batters and potatoes.

Speed 2 (Medium-low) — This speed is for mixing cake batters, mashing potatoes and developing bread dough.

Speed 3 (Medium-high) — This speed is for incorporating air into light batches, as well as finishing whipped items.

Speed 4 (High) — This speed is for maximum and accelerated air incorporation into light batches.

Bowl Scraper Attachment

The Mixer Bowl Scraper Attachment (when ordered) is provided with a separate instruction manual covering its installation, operation, use and care.

CLEANING

WARNING: DISCONNECT ELECTRICAL POWER SUPPLY AND PLACE A TAG AT THE DISCONNECT SWITCH INDICATING THAT YOU ARE WORKING ON THE CIRCUIT BEFORE BEGINNING ANY CLEANING PROCEDURE.

A flat scraper is furnished to aid in cleaning bowls and agitators.

The mixer should be thoroughly cleaned daily. DO NOT use a hose to clean the mixer — wash it with a clean damp cloth. The base allows ample room for cleaning under the mixer. The apron may be removed by loosening the thumb screws.

The drip cup-splash guard (which is secured by three screws) should be removed periodically and wiped clean.

For cleaning the Bowl Guard (including both Wire Cage Assembly and Splash Guard), refer to page 11.

MAINTENANCE

WARNING: DISCONNECT ELECTRICAL POWER SUPPLY AND PLACE A TAG AT THE DISCONNECT SWITCH INDICATING THAT YOU ARE WORKING ON THE CIRCUIT BEFORE BEGINNING ANY MAINTENANCE PROCEDURE.

LUBRICATION

Planetary

The planetary oil should be checked periodically. To check, DISCONNECT ELECTRICAL POWER SUPPLY and remove the drip cup-splash guard, which is secured by three screws. Remove the Planetary Fill Plug (Fig. 5). Oil should be even with the bottom of the fill plug hole. If the oil is not at the proper level, slowly add the recommended planetary lubricant until the proper level is achieved. Replace the fill plug and the drip cup-splash guard.

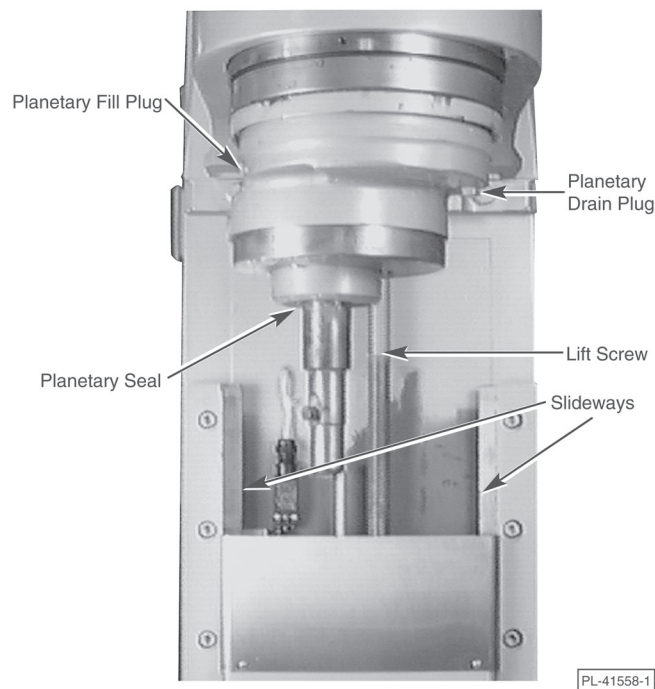

Fig. 5

A Planetary Drain Plug (Fig. 5) is located on the bottom of the planetary. Should draining become necessary, remove the drip cup-splash guard and place a suitable catch pan under the drain plug. Remove the drain plug, allow the oil to completely drain, and replace the drain plug. Remove the fill plug and pour in 6 fluid ounces of the recommended planetary lubricant. Replace the fill plug and the drip cup-splash guard. Contact your local Hobart Service Office for the recommended planetary lubricant.

Planetary Seal

Occasionally, the Planetary Seal (Fig. 5) may become dry and begin to squeak. To correct this, work a little lubrication under the lip of the seal.

Transmission

The transmission oil should be even with the line on the oil level gauge when the motor is NOT running. If the oil falls below this line, DISCONNECT ELECTRICAL POWER SUPPLY and remove the top cover, which is secured by two screws. Remove the Transmission Fill Plug (Fig. 6) and add a small amount of the recommended transmission oil until it returns to the proper level. DO NOT overfill the transmission — leakage may result. Contact your local Hobart Service Office for the recommended transmission oil.

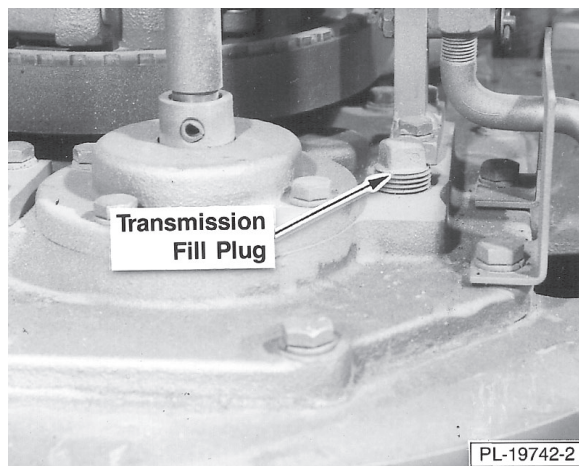

Fig. 6

Bowl Lift

The bowl clamp area of the bowl support, the slideways and lift screw should be lubricated two or three times per year, depending on use. To reach these areas, loosen the thumb screws securing the apron and remove the apron. Remove the inner apron by removing its screws.

The slideways and lift screw (Fig. 5) should be lubricated approximately twice a year. To reach these areas, fully lower the bowl support and remove the apron, which is secured by four thumb screws. Wipe a thin coat of Lubriplate 630AA (supplied) on the bowl clamp area of the bowl supports, each slideway and the lift screw.

Replace the apron.

ADJUSTMENTS

Bowl Clamps

The height of the bowl clamp is controlled by a spring washer and lock nut, which are located on the bottom of the bowl support. Turning the lock nut clockwise will loosen the clamp; turning the lock nut counterclockwise will tighten the clamp. If repeated adjustments are necessary, additional service is indicated. Contact your local Hobart Service Office.

Agitator Clearance

The agitator clearance should be checked with each bowl change. The agitator must not touch the bowl. The maximum clearance between the bottom of the bowl and the B Flat Beater is $\frac{1}{8}$ " ; the maximum clearance between the bottom of the bowl and the E or ED Dough Arm is $\frac{5}{16}$ ".

Install a Bowl and Agitator. If the Bowl and Beater come into contact before the Bowl Support reaches its stop, adjust the Stop Screw upwards following the procedure below.

To Measure the Clearance

Pour enough flour in the bowl to cover the bottom of the bowl where the beater travels. With the bowl fully raised, briefly run the mixer in Speed 1.

Turn off the mixer, DISCONNECT ELECTRICAL POWER SUPPLY, and measure the depth of flour where the beater has traced a path. This measurement should be taken at several points around the bowl to assure accuracy.

To Adjust Bowl / Agitator Clearance

- Remove the Apron (which is secured by four thumbscrews).
- Loosen the Locking Nut on the Stop Screw (Fig. 7), turn the Stop Screw counterclockwise to increase the clearance or clockwise to decrease the clearance.
- Tighten the Locking Nut while holding the Stop Screw.
- After adjustments are made, replace the Apron.
- Reconnect the electrical power supply.
- Carefully operate the bowl lift several times to check the adjustment.

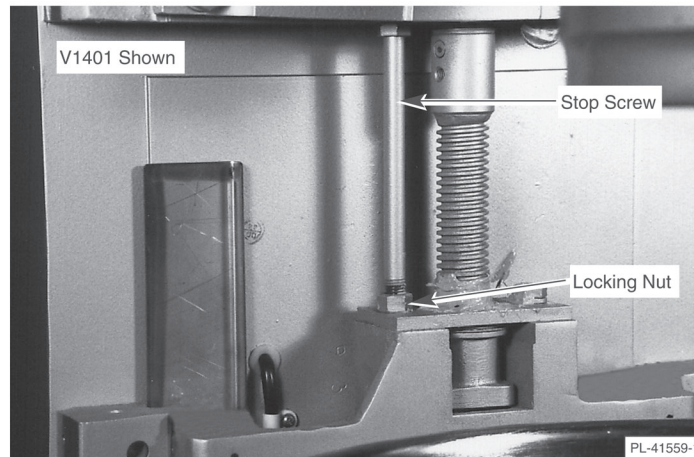

Fig. 7

TROUBLESHOOTING

SYMPTOMS	POSSIBLE CAUSES
Mixer will not start.	<ol style="list-style-type: none">1. Gear shift lever is between gears (not fully engaged).2. Electrical power supply is interrupted. Circuit breaker or disconnect switch is off, or fuse is blown.3. Mixer or attachment is overloaded.4. Bowl is not all the way up.5. Wire Cage Assembly is not in the front-center position.
Agitator touches bowl.	<ol style="list-style-type: none">1. Bowl clamp(s) are not closed.2. Improper agitator clearance —see MAINTENANCE for adjustment procedure.3. Bowl clamp(s) are improperly adjusted — see MAINTENANCE for adjustment procedure.
Planetary seal squeaks.	<ol style="list-style-type: none">1. Seal requires occasional lubrication — see MAINTENANCE.

SERVICE

If service is needed on this equipment, contact your local Hobart Service Office.