



Equipment for the Foodservice Industry

value + quality + service

Work Top Refrigeration

FWDW2-48VC



FWDW2-48VC

Features

Features

- Exterior & interior stainless steel construction
- Heavy duty Embraco compressor
- Self-closing and stay open door
- Efficient refrigeration system
- Recessed door handle
- Removable gasket that is easy to clean and replace
- Casters for easy movement
- Pre-installed shelves

Warranty

- One year parts and labour; Five years on compressor
- Specifications subject to change without notice



WARRANTY
INFORMATION
One year parts and
labour. Five years on
compressor



FWDW2-48VC Specifications

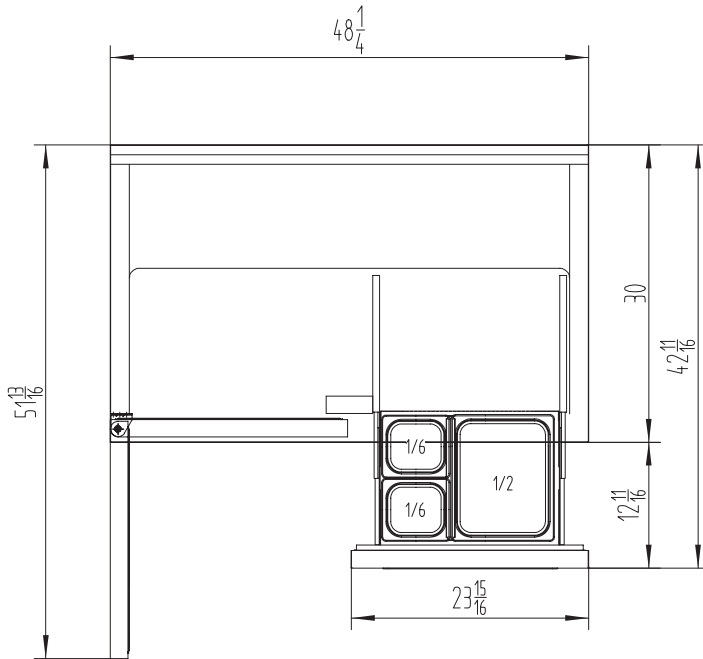
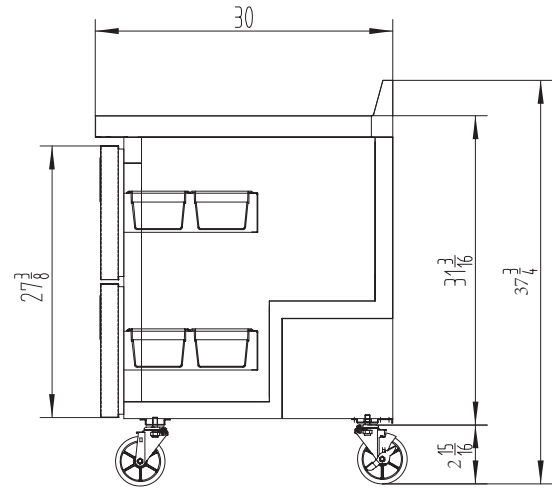
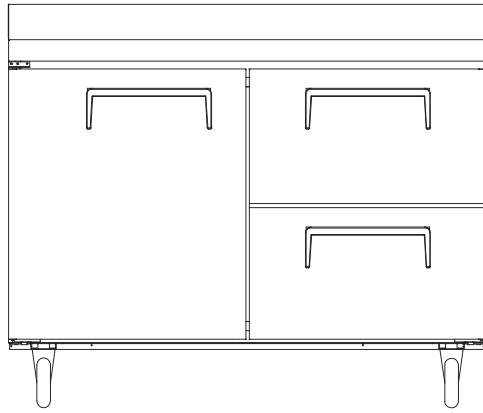

Model	Refrigerant	Doors	Shelves	Dimension (mm) (inch)			HP	Voltage	Amps	Capacity (L) (Cu Ft.)	Net Weight (KG) (LBS)	Temperature Range	NEMA Config.
				L	D	H							
FWDW2-48VC	R404a	1	1	1225	762	919	1/2	115/60	7.2	340	110	-10 ~ 0°C	5-15P ⓘ
				48.2	30.0	36.2				12.0	242	-25 ~ -17°F	