

## Enclosed Bases (with or without Backsplash)



### STAINLESS STEEL ENCLOSED BASES

#### FEATURES

- Keep the work area cleaner and free of clutter
- Available with or without a 4" backplash
- Sliding doors for access to under table storage
- Heavy duty, 18 gauge, Type 430 Stainless Steel top provides long life
- Top is TIG welded
- Entire top surface is machine polished to a satin finish
- Reinforced to exceed industry standards
- Galvanized hat channels are secured to top by structural adhesive and weld studs
- Gussets welded to support hat sections
- Hemmed edges provide strength and safety
- Simple assembly
- Shipped unassembled for reduced cost and space
- Galvanized legs and undershelf for durability and economy
- Sides and doors made with 18 gauge Type 430 Stainless Steel
- Die cast reinforced leg sockets for stability
- Legs are 1 5/8" diameter
- Adjustable ABS bullet feet to accommodate uneven flooring

### ENCLOSED BASES

Product #	Width	Shipping Dimensions			Weight (lbs)
		L"	W"	H"	
TEC3048	48	51	33	8	125
TEC3060	60	63	33	8	147
TEC3072	72	75	33	8	169
TEC3084	84	87	33	8	198
TEC3096	96	99	33	8	218

### ENCLOSED BASES WITH BACKSPLASH

Product #	Width	Shipping Dimensions			Weight (lbs)
		L"	W"	H"	
TECB3048	48	51	33	12	131
TECB3060	60	63	33	12	153
TECB3072	72	75	33	12	175
TECB3084	84	87	33	12	206
TECB3096	96	99	33	12	228

#### DIMENSIONS

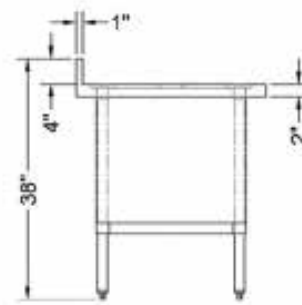
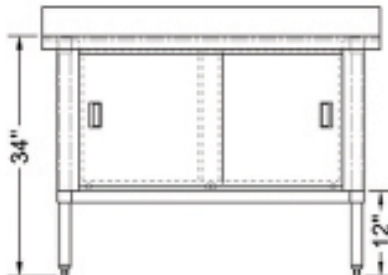
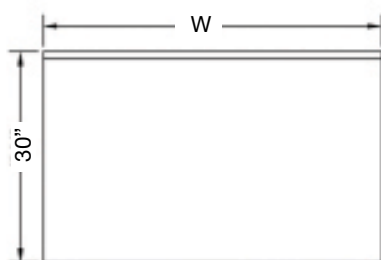

Specifications subject to change without notice.