

Tables

Equipment Stands



TES2424 NSF

STAINLESS STEEL EQUIPMENT STANDS

FEATURES

- 1½" riser on three sides to securely hold equipment in place
- Heavy duty, 18 gauge, Type 430 Stainless Steel top provides long life
- Top is TIG welded
- Entire top surface is machine polished to a satin finish
- Reinforced to exceed industry standards
- Galvanized hat channels are secured to top by structural adhesive and weld studs
- Gussets welded to support hat sections
- Hemmed edges provide strength and safety
- Simple assembly
- Shipped unassembled for reduced cost and space
- Galvanized legs and undershelf for durability and economy
- Die cast reinforced leg sockets for stability
- Legs are 1 5/8" diameter
- Adjustable ABS bullet feet to accommodate uneven flooring

DIMENSIONS

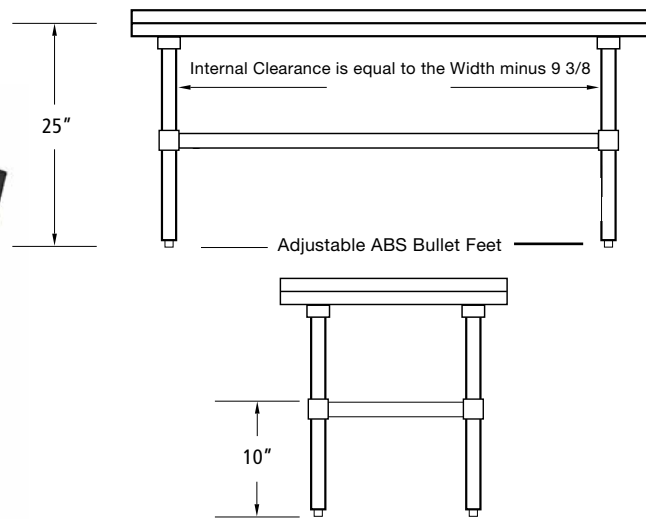

EQUIPMENT STANDS 24" DEPTH

Product #	Width	Shipping Dimensions			Weight (lbs)
		L"	W"	H"	
TES2412	12	14	26	5	31
TES2414	14	16	26	5	33
TES2416	16	18	26	5	35
TES2418	18	20	26	5	38
TES2424	24	26	26	5	40
TES2430	30	32	26	5	45
TES2436	36	38	26	5	49
TES2448	48	50	26	5	60
TES2460	60	62	26	5	80
TES2472	72	74	26	5	98

EQUIPMENT STANDS 30" DEPTH

Product #	Width	Shipping Dimensions			Weight (lbs)
		L"	W"	H"	
TES3012	12	14	32	5	32
TES3014	14	16	32	5	34
TES3016	16	18	32	5	37
TES3018	18	20	32	5	40
TES3024	24	26	32	5	48
TES3030	30	32	32	5	52
TES3036	36	38	32	5	57
TES3044	44	46	32	5	65
TES3048	48	50	32	5	69
TES3060	60	62	32	5	75
TES3072	72	74	32	5	100

Specifications subject to change without notice.

