



FEATURES & BENEFITS

- Stainless Steel Constructed
- Compact & Illuminated
- Adjustable Feet
- Easy to Read Thermometer
- Adjustable Temp Control up to 175°F
- Removable Glass Panels for Easy Cleaning
- Internal Water Pan for Added Humidity
- (4) Rotating Shelves—4" Shelf Spacing

OPTIONS & ACCESSORIES

- Pass-Thru Doors (1 Front/1Rear) (*Suffix PT*)

FINISH

Stainless Steel

STANDARD PRODUCT WARRANTY

One Year Parts & Two Years Labor

DIMENSIONS & SHIPPING WEIGHT

22 3/8" W X 23 3/4" D X 29 1/8" H
(567 mm X 604 mm X 739 mm)
150 lb (68 kg)

STANDARD PRODUCT WARRANTY

One Year Parts & Two Years Labor

ELECTRICAL SYSTEM

1 Phase:

- 120V - 8.4 A - 1.1 kW - 60 Hz - 2 wires + Ground - NEMA 5-15P

CAPACITY

- (4) 19" (508 mm) Pizzas—1 Per Shelf
- (16) 9" (229 mm) Pizzas—4 Per Shelf
- (16) Chickens

DOOR OPENING

19 3/4" (507 mm)

DRAWINGS

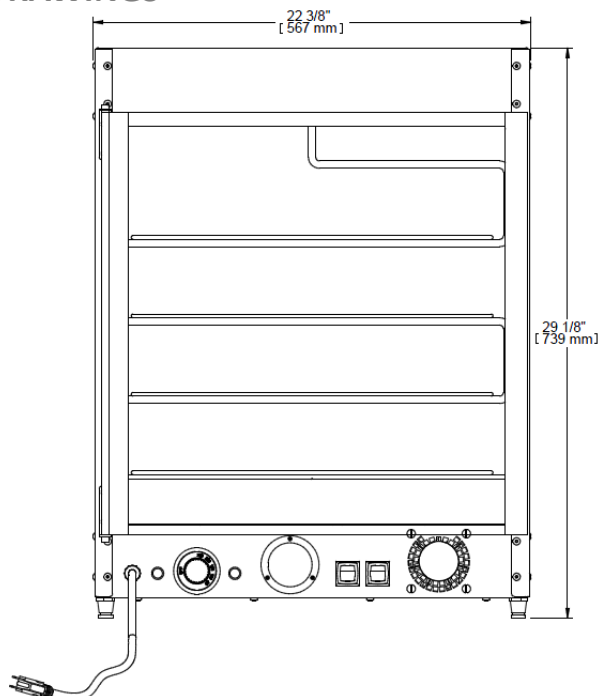

SHORT SPECIFICATION

Warming Merchandiser, Stainless Steel Construction, Electric, 120V 60Hz Single Phase, NEMA 5-15P Power Cord Included, Removable Glass Panels, Fully Illuminated, (4) Rotating Shelves, 4" Shelf Spacing, One Year Labor & Two Year Parts Warranty