

**Warmer, Merchandiser**  
**MODEL: DRP3**



**FEATURES & BENEFITS**

- Stainless Steel Constructed
- Compact & Illuminated
- Adjustable Feet
- Easy to Read Thermometer
- Adjustable Temp Control up to 175°F
- Removable Glass Panels for Easy Cleaning
- Internal Water Pan for Added Humidity
- (3) Removable Stainless Steel Shelves—4" Shelf Spacing

**OPTIONS & ACCESSORIES**

- Pass-Thru Doors (1 Front/1Rear) (*Suffix PT*)

**FINISH**

Stainless Steel

**STANDARD PRODUCT WARRANTY**

One Year Parts & Two Years Labor

**DIMENSIONS & SHIPPING WEIGHT**

20 1/8" W X 21 5/8" D X 21 3/8" H  
(511 mm X 556 mm X 546 mm)  
80 lb (36 kg)

**STANDARD PRODUCT WARRANTY**

One Year Parts & Two Years Labor

**ELECTRICAL SYSTEM**

1 Phase:

- 120V - 8.4 A - 1.1 kW - 60 Hz - 2 wires + Ground - NEMA 5-15P

**CAPACITY**

- (3) 18" (508 mm) Pizzas—1 Per Shelf
- (12) 9" (229 mm) Pizzas—4 Per Shelf
- (12) Chickens

**DOOR OPENING**

18 3/4" (477 mm)

**DRAWINGS**

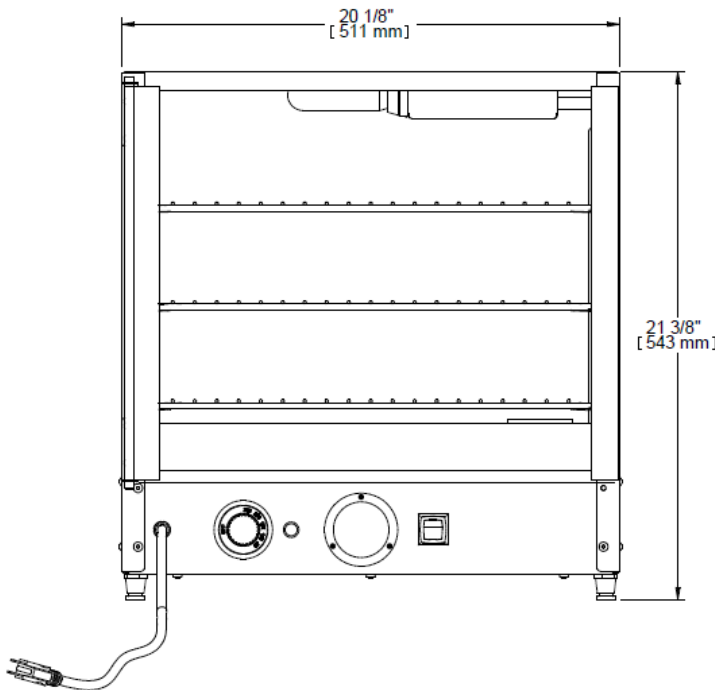

**SHORT SPECIFICATION**

Warming Merchandiser, Stainless Steel Construction, Electric, 120V 60Hz Single Phase, NEMA 5-15P Power Cord Included, Removable Glass Panels, Fully Illuminated, (3) Removable Shelves, 4" Shelf Spacing, One Year Labor & Two Year Parts Warranty