



DREAM

PERFORMANCE AND QUALITY

Make Classic Slush, Frozen cocktails or Dairy Slush



Quality Frozen drinks Production

Thanks to the H-O-T system and the type of feed (gravity), users can set the desired consistency for classic Slush, creamy dairy slushes or frozen cocktails with more pronounced ice crystals.

PERFORMANCE AND QUALITY

Dream software prepares the mixture by modulating the cylinder temperature to create the ideal compact, frozen drink slush structure with the presence of ice crystals.

Electronic consistency Control

The electronic control system that allows you to easily change the consistency of the frozen drink according to the type of product inserted or desired style.





PERFORMANCE AND QUALITY

Gravity Feeding System

For unique styles of frozen drinks. The different diameters of the holes on the feeding tube naturally dose the mixture with or without overrun.



High Efficiency beater

Obtains the maximum performance for product extraction. The metal body and interchangeable plastic flap allows user to adjust the Ice crystal size for a dedicated shake style.

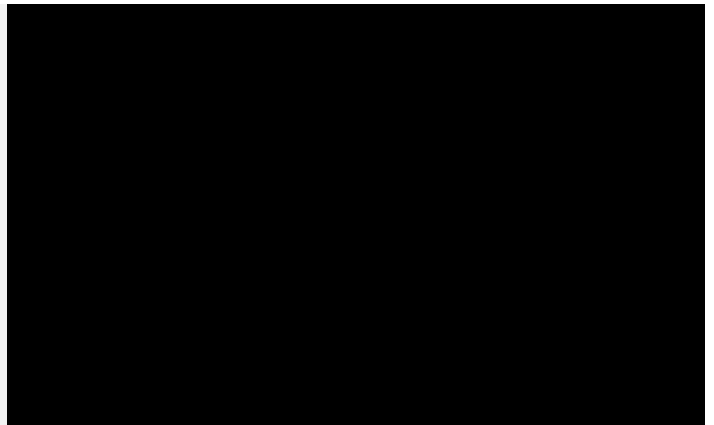

7.4 qt (7l) Cylinder

Optimizes the refrigeration process, speeding up freezing times and eliminating energy waste. Thanks to the new position of the feed hole, the pre-loading operation is simple and safe. The dimensions of this cylinder, are functional to the high production capacity.



CONVENIENCE

New solutions for maximum convenience during use



Adjustable dispensing speed

Adjustable delivery flow to meet all volume and speed needs.



Tank agitator

Prevents product stratification during storage and improves cold transfer during refrigeration.

Scan the QR Code on the front of the machine to access the most up to date equipment information: Instruction Manual, Spare parts, Operation videos, and more



> SAVINGS

New high-performance electric gearmotors and condensers

Zero Clearance space

Installation space is optimized, thanks to the rear chimney, making it possible to place the machines side by side.



> SAFETY

More operational safety and more control during production

Ergonomic Design

Reduced risk of injury, with corners even rounder where the operator works.



Button lock

For added security, the display buttons can be locked to prevent accidental errors.



Black out

After a power failure, if the temperature-time parameters guarantee that the mixture has not undergone any alteration, the machine resumes the program in progress.

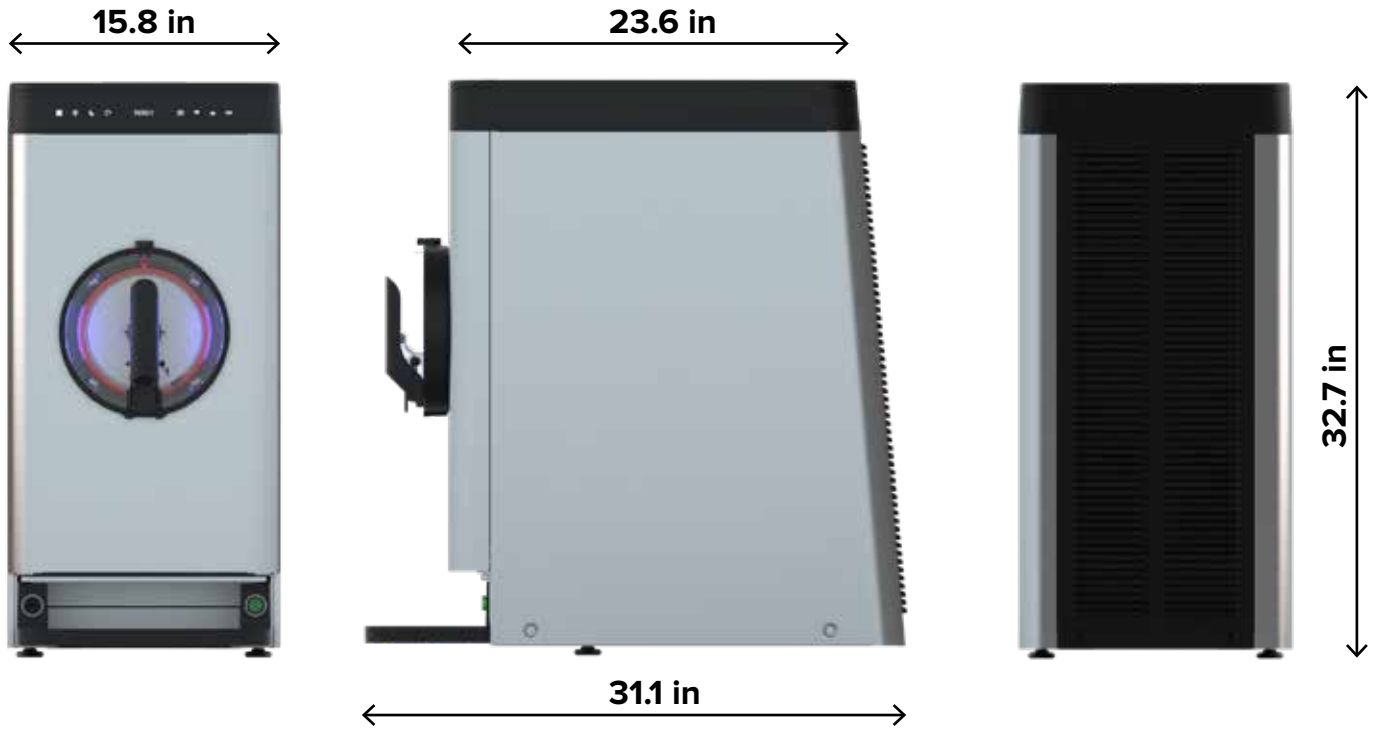

	Flavours	Mix Delivery System	Hourly production (16oz / 0.4lt)	Hopper Capacity	Cylinder Capacity	Maximum Fuse Size	Minimum Circuit Ampacity	Power Supply	Cooling System	Refrigerant	Net Weight
Dream	1	Gravity	125*	19 quarts <i>18 liters</i>	7.4 quarts <i>7 liters</i>	12 A	12 A	220-230V 50-60 Hz 1 Phase	Air	R290	220 lbs <i>100 kgs</i>

Production capacity depends on the mix used and the room temperature

All specifications mentioned must be considered approximate. The right to modify is reserved without notice all parts deemed necessary