

CL60 Pusher Feed Head

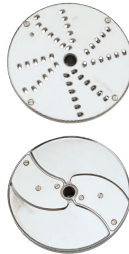

52 DISCS

9 Dicing
4 French Fry Kits



D Number of meals per service	300 to 3000
Theoretical output per hour*	3970 lbs

A SALES FEATURES

CL 60 Pusher Feed Head is ideal for slicing, ripple cutting, grating, dicing, shredding and making french fries from all types of fruit and vegetables, as well as grating cheese, in very large quantities.

B TECHNICAL FEATURES

CL60 Pusher Feed Head – Three-phase. Power - 3HP. 2 speeds 425 and 850 rpm. Magnetic safety system, motor brake and lever-activated auto restart. This metal Vegetable Preparation Machine has a lateral ejection facility and is equipped with 2 hoppers: 1 XL full moon hopper, diameter: diameter 7", and 1 cylindrical hopper diameter 3". Stainless steel motor base and chute. This model is equipped with with 2 wheels and a handle for easy movement. Suitable for up to 3000 covers per service. Included : 28064 (3mm) 1/8" slicing disc and 28058 (3mm) 1/8" grating disc and 2 disc racks. Large choice of 52 discs available.

Select your options at the back page, **F** part.

C TECHNICAL DATA

Output power	3HP
Electrical data	Three phase - 6.5 Amp
Speeds	425 and 850 rpm
Dimensions (HxLxW)	45" x 24" x 16"
Rate of recyclability	95%
Net weight	154 lbs
Nema #	L15 - 20P
Reference	CL 60 Pusher Series E 208-220V/60/3

E PRODUCT FEATURES / BENEFITS

MOTOR BASE

- Industrial induction motor for intensive use.
- Power - 3HP
- Stainless steel motor base and shaft.
- Magnetic safety system with motor brake and lever-activated auto restart.
- 2 Speeds 425 and 850 rpm

VEGETABLE PREPARATION FUNCTION

- Vegetable Preparation Machine equipped with 2 hoppers: 1 XL full moon hopper to accommodate a whole cabbage or up to 15 tomatoes and 1 cylindrical hopper for long, delicate vegetables.
- Removable continuous feed lead. Tilting of the feed heads in line with the motor base for space-saving.
- Reversible discharge plate for processing delicate produce.
- Lateral ejection facility for greater user comfort.
- Optimum size and height. CL60 is equipped with 2 wheels and a handle, guaranteeing very easy movement.
- Lever-activated auto restart (by the pusher)
- Lever-assisted facility requires less effort from the operator and increases output.
- Vertical pusher pressure exerted on vegetables to ensure uniform cuts.
- Large choice of 52 discs available.
- Included : 28064 (3mm) 1/8" slicing disc and 28058 (3mm) 1/8" grating disc and 2 disc racks.
- Stainless steel blades on slicing discs, blades on Julienne discs and grating discs are removable.
- 3 positions for optimum operator comfort. Lever-activated auto restart

MASHED POTATO FUNCTION

- option : Mashed Potato Kit

STANDARDS

ETL electrical and sanitation Listed/ cETL (Canada)



* Results may differ depending on the type of the hopper used, the choice of the cut and the setup of the workstation.

CL60 Pusher Feed Head

CL60 Pusher Feed Head

F OPTIONAL ACCESSORIES

- Automatic Feed Head : with feeding tray ref 39681
- 4 tubes Feed Head: Special long vegetables ref 28162
- Straight and bias cut hole hopper: for long vegetables and bias cuts ref 28157.
- Ergo-Mobile Cart : no pans provided. Can accomodate three full-size gastronorm pans ref 49066
- Dice Cleaning Kit : cleaning tool for dicing grids ref 39881
- Mashed Potato Attachment 3 mm : ref 28188
- Wall-mounted disc holder for 8 large discs: ref 107 812

SUGGESTED PACKS OF DISCS

3 disc package	5mm (3/16") coarse grating, 6mm (1/4" x 1/4") julienne and 5mm (3/16") slicing discs.
5 disc package	5mm (3/16") coarse grating; 6mm (1/4" x 1/4") julienne; 5mm (3/16"), 10mm (3/8") slicing discs; 10x10mm (3/8" x 3/8") dicing grid
16 disc package	Slicers - (0.8mm) 1/32", (2mm) 5/64" & (5mm) 3/16". 2 graters - (2mm) 5/64" & (5mm) 3/16"; 3 dicing - (5x5x5mm) 3/16", (10x10x10mm) 3/8" & (14x14x5mm) 9/16"x9/16"x3/16". 2 Julienne sticks - (2.5 x 2.5mm) 1/10"x1/10" & (2 x 10mm) 5/64"x3/8". D-Clean Kit and 2 disc holders.

OPTIONAL DISCS



SLICING

0.6 mm	28166
0.8 mm	28069
1 mm (1/32")	28062
2 mm (5/64")	28063
3 mm (1/8")	28064
4 mm (5/32")	28004
5 mm (3/16")	28065
6 mm (1/4")	28196
8 mm (5/16")	28066
10 mm (3/8")	28067
14 mm (9/16")	28068
20 mm (25/32")	28132
25 mm (1")	28133
cooked potatoes 4 mm (5/32")	27244
cooked potatoes 6 mm (1/4")	27245



RIPPLE CUTTING

2 mm (5/64")	27068
3 mm (1/8")	27069
5 mm (3/16")	27070



GRATERS

1.5 mm (1/16")	28056
2 mm (5/64")	28057
3 mm (1/8")	28058
4 mm (5/32")	28136
5 mm (3/16")	28163
7 mm (9/32")	28164
9 mm (11/32")	28165
Röstis potatoes	27164
Raw potatoes	27219
Fine Pulping disc	28055
Hard Cheese grate	28061



JULIENNE

1x8 mm tagliatelle (1/32"x5/16")	28172
1x26 onion/cabbage (1/32"x1 1/4")	28153
2x2 mm (5/64" x 5/64")	28051
2x4 mm (5/64" x 5/32")	27072
2x6 mm (5/64" x 1/4")	27066
2x8 mm (5/64" x 5/16")	27067
2x10 tagliatelle (5/64"x3/8")	28173
2.5x2.5 mm (1/10" x 1/10")	28195
3x3 mm (1/8" x 1/8")	28101
4x4 mm (5/32" x 5/32")	28052
6x6 mm (1/4" x 1/4")	28053
8x8 mm (5/16" x 5/16")	28054



DICING EQUIPMENT

5x5 mm (3/16")	28110
8x8 mm (5/16")	28111
10x10 mm (3/8")	28112
12x12 mm (15/32")	28197
14x14x5 mm Mozzarella (9/16"x9/16"x3/16")	28181
14x14x10mm (9/16"x9/16"x3/8")	28179
14x14 mm (9/16")	28113
20x20 mm (25/32")	28114
25x25 mm (1")	28115
2" Lettuce Cut	28180



FRENCH FRY EQUIPMENT

8x8 mm (5/16" x 5/16")	28134
8x16 mm (5/16" x 5/8")	28159
10x10 mm (3/8" x 3/8")	28135
10x16 mm (3/8" x 5/8")	28158

G ELECTRICAL DATA

208-240V/60/3 - delivered with cord and plug.

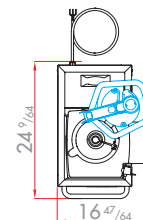
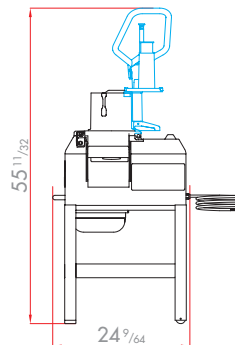
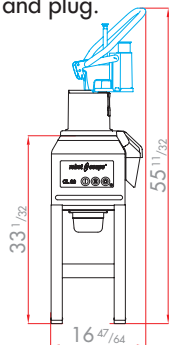
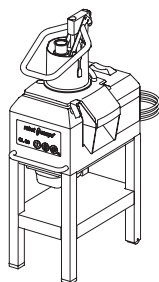

robot coupe®



VEGETABLE PREPARATION MACHINES

CL 55 • CL 60



RESTAURANTS - INSTITUTIONS - CATERERS

MULTICUT PACK OF 16 DISCS

FRUIT AND VEGETABLES IN ALL SHAPES AND SIZES

With evolving nutritional requirements, Chefs in the mass catering sector are looking for solutions to serve more fruit and raw vegetables.

The aim is to improve the nutritional quality of meals served in school canteens, company cafeterias and healthcare institutions.

It is a great opportunity for Chefs to provide creative and original cuts to present fresh fruit and vegetables in a more attractive way.

Robot-Coupe is innovating with its latest launch, the MultiCut Pack, with 16 discs included.

Slicers



1 mm (1/32")

Cabbage, onion, parsnip, courgette, turnip, celeriac, apple.



2 mm (5/64")

Pepper, celeriac, carrot, leek, lemon, banana, kiwi.



4 mm (5/32")

Tomato, courgette, mushroom, eggplant.



Graters



1.5 mm (1/16")

Carrots, celeriac, parsnip.



3 mm (1/8")

Beetroot, cabbage, carrots, cheese.



French Fries



10 x 10 mm (3/8" x 3/8")

Potato, turnip, celeriac, courgette, sweet potato, parsnip.



Dicing



5 x 5 x 5 mm (3/16" x 3/16" x 3/16")

Beetroot, courgette, cucumber, apple, pear, melon, mango.



10 x 10 x 10 mm (3/8" x 3/8" x 3/8")

Tomato, courgette, pepper, onion, apple.



20 x 20 x 20 mm (25/32" x 25/32" x 25/32")

Pepper, onion, courgette, water eggplant, melon, apple, pineapple and iceberg lettuce salad.



Julienne



2 x 10 mm (5/64" x 3/8")

Carrot, cucumber, courgette, beetroot.



2.5 x 2.5 mm (1/10" x 1/10")

Carrot, cucumber, radish, celeriac, courgette.



4 x 4 mm (5/32" x 5/32")

Carrot, courgette, cucumber, celeriac, sweet potato, radish, beetroot.



D-Clean Kit



Cleaning tool for dicing grids (5 mm (3/16"), 8 mm (5/16") and 10 mm (3/8"))



Disc holders



Disc holders for 16 discs

CL 55 WORKSTATION COMPLETE VEG. PREP. SOLUTION

Up to
2 645 lbs
of vegetables
per hour

New

ADJUSTABLE CART 3 HEIGHTS



To collect the vegetables directly from the ejection outlet.
Possibility to put 2 containers to transport vegetables or accessories.



Can be used to transport attachments.



MULTICUT PACK OF 16 DISCS INCLUDED

AUTOMATIC FEED-HEAD



For all vegetables in bulk (tomatoes, onions, potatoes...)



PUSHER FEED-HEAD



Specially intended for bulky vegetables (e.g. cabbage or celeriac). With a built-in cylindrical hopper for long vegetables such as cucumber.



MASHED POTATO KIT 3 mm (1/8")



Ideal for mashing large amounts of fresh potato.



ADJUSTABLE CART GN 1X1



3 heights adjustable cart for transport, loading and reception. Delivered with 2 containers GN 1x1.

▶ CL 55 Pusher Feed-Head

Up to
1 000
meals

AS OPTION
+52
DISCS



* The Pusher Feed-Head is also perfect for special precision cuts (e.g. carrot tagliatelle or cucumber julienne).

PUSHER FEED-HEAD

IMPROVED ERGONOMICS



New handle design requires less effort from operator



On CL 60 only

To ensure optimum user comfort, the handle can be fixed at three different heights.

EXTRA PRECISE



Cylindrical hopper (Ø 58 mm) ensuring a uniform cut for long items.

EXTRA LARGE



The XL hopper can accommodate a whole cabbage or up to 15 tomatoes.
Full-moon Feed-Head of 238 cm² and 4.4 quarts capacity.

AS OPTION
+52
DISCS

Up to
3 000
meals

▶ CL 60 Pusher Feed-Head



Stainless steel container for cutting tools

ADJUSTABLE FOOT
Machine stable on all floors

RUGGED CONSTRUCTION

Stainless-steel motor base and mobile stand

EASY CLEANING

All parts which come into contact with foodstuffs can easily be removed for cleaning, thus maintaining the highest standards of hygiene.

SAFETY SYSTEM

It is impossible to gain access to the sharp cutting blades while they are moving.

EASY TO HANDLE

The machine can easily be moved around on its wheeled stand.

SPEED

1 speed: 425 rpm single-phase

RUGGED CONSTRUCTION

100% stainless steel except for the aluminium feed-head base.

PRODUCTIVITY

Stainless-steel feed tray for continuous input.

EASY TO HANDLE

The machine is extremely easy to move around, on account of its compactness, its two wheels and its handle

SPACE-SAVING

Tilting of the feed heads in line with the motor base.

SPEED

2 speeds: 425 rpm & 850 rpm three-phase

CL 60 WORKSTATION COMPLETE VEG. PREP. SOLUTION

Up to
3 970 lbs
of vegetables
per hour

New



ADJUSTABLE FOOT

OPTION

WORKSTATION STORAGE CART



- Place all accessories on the cart!
- **16 discs** and **8 kits**
- **Container GN 1x1** for kitchenware
- **3 Feed-Heads**



MULTICUT PACK OF 16 DISCS INCLUDED

AUTOMATIC FEED-HEAD



For all vegetables in bulk (tomatoes, onions, potatoes...)



PUSHER FEED-HEAD



Specially intended for bulky vegetables (e.g. cabbage or celeriac)



4 TUBES FEED-HEAD



Specially intended for long vegetables, like cucumbers or zucchini.

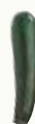

MASHED POTATO KIT 3 mm (1/8")



Ideal for mashing large amounts of fresh potato.



ERGO MOBILE CART



Can accommodate three full-size gastronorm pans



THE WIDEST VARIETY OF CUTS

▶ Slicers

15 discs



- 0.6 mm
- 0.8 mm
- 1 mm (1/32")
- 2 mm (5/64")
- 3 mm (1/8")
- 4 mm (5/32")
- 5 mm (3/16")
- 6 mm (1/4")

- ref.
- 28166
- 28069
- 28062
- 28063
- 28064
- 28004
- 28065
- 28196

- 8 mm (5/16")
- 10 mm (3/8")
- 14 mm (9/16")
- 20 mm (25/32")
- 25 mm (1")
- Cooked potatoes 4 mm (5/32")
- Cooked potatoes 6 mm (1/4")

- ref.
- 28066
- 28067
- 28068
- 28132
- 28133
- 27244
- 27245



0.6 mm → 25 mm

▶ Ripple-cut

3 discs



- 2 mm (5/64")
- 3 mm (1/8")
- 5 mm (3/16")

- ref.
- 27068
- 27069
- 27070



2 mm → 5 mm

▶ Grater

11 discs



- 1.5 mm (1/16")
- 2 mm (5/64")
- 3 mm (1/8")
- 4 mm (5/32")
- 5 mm (3/16")
- 7 mm (9/32")

- ref.
- 28056
- 28057
- 28058
- 28073
- 28059
- 28016

- 9 mm (11/32")
- Rösti potatoes
- Raw potatoes
- Fine Pulping disc
- Hard cheese grate

- ref.
- 28060
- 27164
- 27219
- 28055
- 28061



1.5 mm → 9 mm

▶ Julienne

12 discs



- 1 x 8 mm tagiatelle (1/32" x 5/16")
- 1 x 26 mm onion/cabbage (1/32" x 1 1/2")
- 2 x 2 mm (5/64" x 5/64")
- 2.5 x 2.5 mm (1/10" x 1/10")
- 2 x 4 mm (5/64" x 5/32")
- 2 x 6 mm (5/64" x 1/4")

- ref.
- 28172
- 28153
- 28051
- 28195
- 27072
- 27066

- 2 x 8 mm (5/64" x 5/16")
- 2 x 10 mm tagiatelle (5/64" x 3/8")
- 3 x 3 mm (1/8" x 1/8")
- 4 x 4 mm (5/32" x 5/32")
- 6 x 6 mm (1/4" x 1/4")
- 8 x 8 mm (5/16" x 5/16")

- ref.
- 27067
- 28173
- 28101
- 28052
- 28053
- 28054



1.8 mm → 8x8 mm

▶ Dicing Kits

10 sets



- 5 x 5 x 5 mm (3/16")
- 8 x 8 x 8 mm (5/16")
- 10 x 10 x 10 (3/8")
- 12 x 12 x 12 (15/32")
- 14 x 14 x 5 mm Mozzarella (9/16" x 9/16" x 3/16")

- ref.
- 28110
- 28111
- 28112
- 28197
- 28181

- 14 x 14 x 10 mm (9/16" x 9/16" x 3/8")
- 14 x 14 x 14 mm (9/16")
- 20 x 20 x 20 mm (25/32")
- 25 x 25 x 25 mm (1")
- 2" Lettuce Cut

- ref.
- 28179
- 28113
- 28114
- 28115
- 28180



5x5x5 mm → 25x25x25 mm

▶ French Fries

4 sets



- 8 x 8 mm (5/16" x 5/16")
- 8 x 16 mm (5/16" x 5/8")
- 10 x 10 mm (3/8" x 3/8")
- 10 x 16 mm (3/8" x 5/8")

- ref.
- 28134
- 28159
- 28135
- 28158

8x8 mm → 10x16 mm

▶ Mashed Potato Kit

2 sets



- ref.
- Ø 3 mm (1/8") 28208
- Ø 6 mm (1/4") 28210

▶ OPTIONAL ATTACHMENTS CL 55 AND CL 60



4 Straight holes feed-head

- Designed for the preparation of long vegetables in large outputs.
- Diameters of the tubes: 2 tubes of 50 mm (2 inches) and 2 tubes of 70 mm (2.8 inches).



Straight and bias cut feed head

- Designed for the preparation of long vegetables and biased cut.
- This head is equipped with a hole and pusher Ø 75 mm (2.9 inches), one insert and pusher Ø 50 mm (2 inches).



Vegetable Preparation Machines

Floor models



The Products Advantages:

Processing capacity:

- Large hopper feed head (36 57/64" in²) for large vegetables processing and an automatic feed head for continuous feeding.
- Powerful motor which guarantees large outputs (up to 3970 lbs)

Wide range of cut:

- Complete selection of 52 discs for slicing, grating, julienne, dicing and making French Fries.
- 4 different type of feed heads to guarantee a wide variety of tasks.

Simple and sturdy design:

- Mainly stainless steel for easy cleaning and a longer life.
- Parts in food contact are easy to dismantle and clean.



Number of covers:

up to 3 000.



Target:

For Hospitals & Institutions, Hotels, C P U's and Food Manufacturer's.



In brief:

- **High performance, sturdy, easy to clean and maintain**, simple to use and versatile. Quite simply incomparable.

	Auto Feed Head	Pusher Feed Head	4 Tubes-feed Head	Ergo mobile cart	Mobile stand	Mashed Potato Kit	Workstation Storage Cart	MultiCut pack of 16 discs
CL 55 Workstation	✓	✓	Option	ption	✓	✓	Option	✓
CL 55 Two feed heads	✓	✓	Option	Option	✓	Option	Option	Option
Pusher feed head CL 55	Option	✓	Option	Option	✓	Option	Option	Option
CL 60 Workstation	✓	✓	✓	✓	Option	✓	Option	✓
CL 60 Two feed heads	✓	✓	Option	Option	Option	Option	Option	Option
Pusher feed head CL 60	Option	✓	Option	Option	Option	Option	Option	Option

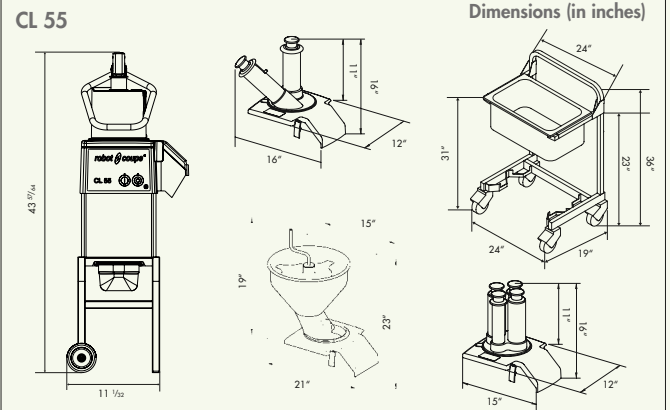

	Electrical data			
	Speed (Rpm)	Power (HP)	Intensity (Amp.)	Voltage
CL 55	425	2.5	9.5	120V/60 Hz / 1
CL 60	425 & 850	3	6.5	208-240/60 Hz / 3

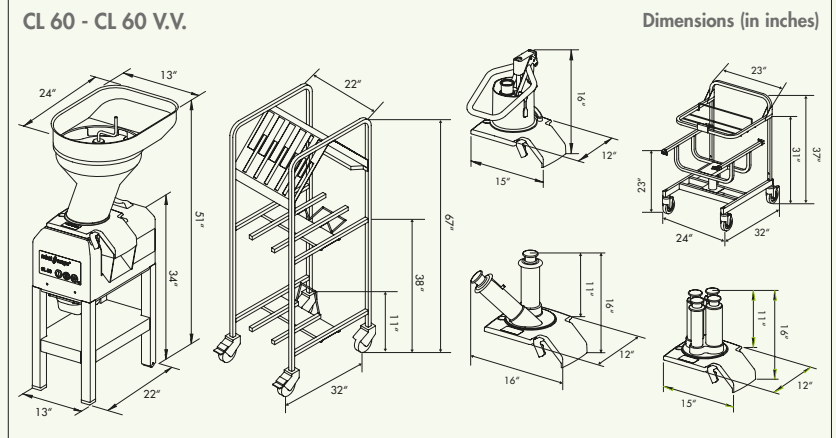

robot coupe®

Robot Coupe® U.S.A., Inc.

264 South Perkins Street,
Ridgeland, MS 39157

Ph.: 1-800-824-1646 (601) 898-8411

Fax: (601) 898-9134

email: info@robotcoupeusa.com

www.robotcoupeusa.com

DISTRIBUTOR



We reserve the right to alter at any time without notice the technical specifications of this appliance. None of the information contained in this document is of a contractual nature. Modifications may be made at any time.

© All rights reserved for all countries by: ROBOT COUPE S.N.C.