

Project _____
Item _____
Quantity _____
FCSI section _____
Approval _____
Date _____

Combi oven

C4ET 10.10 EB

Model

Convotherm 4 easyTouch

- easyTouch
- 11 slide rails
- Electrical
- Boiler
- Right-hinged door



Key features

- ACS+ operating modes: Steam, combi-steam, hot air
- ACS+ extra functions:
 - Crisp&Tasty - 5 moisture-removal settings
 - BakePro - 5 levels of traditional baking
 - HumidityPro - 5 humidity settings
 - Controllable fan - 5 speed settings
- easyTouch 9" full-touch screen
- ConvoClean+ fully automatic cleaning system with eco, regular and express modes - with optional single-dose dispensing
- Ethernet port
- HygienicCare
- USB port integrated in the control panel
- TriColor indicator ring - indicates the current operating status
- Steam generated by high-performance boiler outside the cooking chamber
- Right-hinged door
- KNLZ listed for ventless operation, local codes prevail as in NFPA 96-1994

Standard features

- ACS+ (Advanced Closed System +) operating modes:
 - Steam (86-266°F) with guaranteed steam saturation
 - Combi-steam (86-482°F) with automatic humidity adjustment
 - Hot air (86-482°F) with optimized heat transfer
- HygienicCare - food safety provided by antibacterial surfaces:
 - easyTouch control panel
 - Door handle and recoil hand shower
- easyTouch user interface:
 - 9" full-touch screen
 - Press&Go - automatic cooking with quick-select buttons
 - TrayTimer - oven-load management for different products at the same time
 - Regenerate+ - flexible multi-mode retherm function
 - ecoCooking - energy-save function
 - Low-temperature cooking / Delta-T cooking
 - Cook&Hold - cook and hold in one process
 - 399 cooking profiles each containing up to 20 steps
 - On-screen help with topic-based video function
 - Start-time preset
- Multi-point core temperature probe
- Door handle with safety latch and slam function
- Data storage for HACCP and pasteurization figures
- Preheat and cool down function

Options

- Steam and vapor removal - built-in condenser (upon request)
- Disappearing door - more space and added safety (see page 2)
- ConvoGrill with grease management function (upon request)
- ConvoSmoke - built in food-smoking
- Marine version (see separate data sheet)
- Security model
- Available in various voltages
- Sous-vide probe, external connection
- Core temperature probe, external connection

Accessories

- ConvoLink - HACCP and cooking-profile management PC software
- Signal tower - indicates the operating status from a distance
- Banquet system (optionally as a package or individually): Plate rack, mobile shelf rack, transport trolley, thermal cover
- Equipment stands in various sizes and designs
- Racks for cooking and baking
- Stacking kits
- Cleaning products for the fully automatic ConvoClean cleaning system

Commercial combination oven with integral systems for limiting the emissions of grease laden air. This product conforms to the ventless operation recommendations set forth by NFPA96 using EPA202 test method.



Front view

(disappearing door optional)

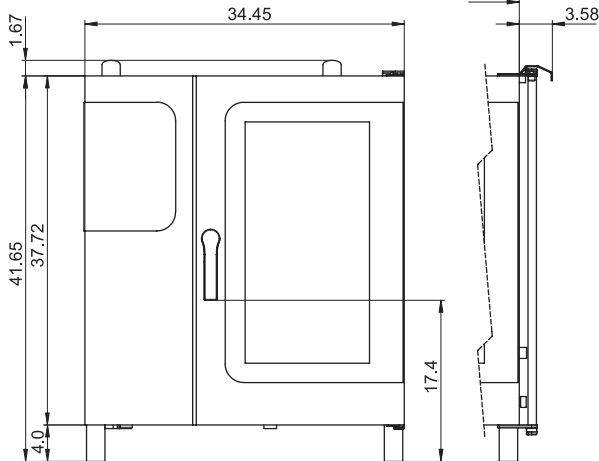
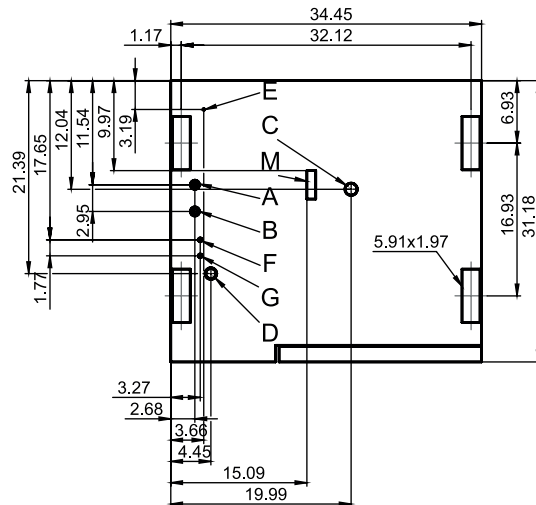
Connection positions

- A Water connections (for boiler)
- B Water connections (for cleaning, recoil hand shower)
- C Drain connection (2" I. D.)
- D Electrical connection
- E Electrical ground
- F Rinse-aid connection
- G Cleaning-agent connection
- H Air vent (2" I. D.)
- I Ventilation port
- M Safety overflow 3.2" x 1"

View from above with wall clearances

(disappearing door optional)

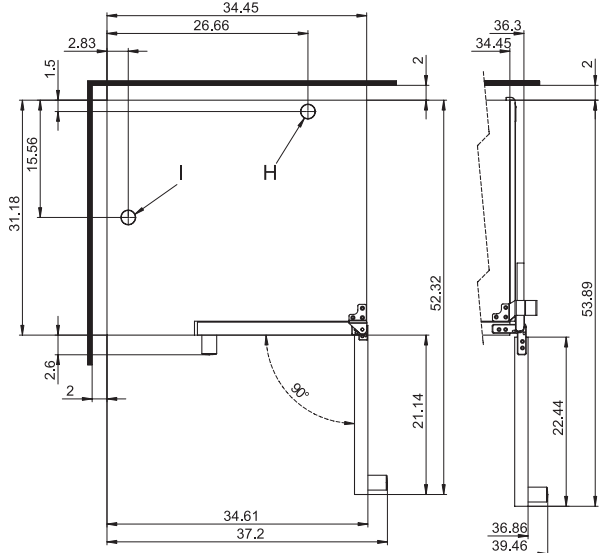
Dimensions and weights

| Dimensions including packaging | |
|--|---------------------|
| Width x Height x Depth | 43.3" x 50.4" x 37" |
| Weight | |
| Net weight without options* / accessories | 315 lbs |
| Packaging weight | 66 lbs |
| Safety clearances** | |
| Rear | 2" |
| Right (right-hinged door) | 2" |
| Right (disappearing door pushed back) | 5" |
| Left (18" clearance recommended for service) | 2" |
| Top*** | 20" |

* Max. weight of options: 46 lbs.

** Minimum clearance from heat sources: 20".

*** Depends on the type of exhaust system and the ceiling's characteristics.

Installation requirements

| | |
|---|----------------|
| Max. absolute appliance inclination during operation* | max. 2° (3.5%) |
|---|----------------|

* Adjustable appliance feet as standard.

Loading capacity

| | |
|--|---------|
| Max. number of food containers | |
| [Unit has 11 slide rails; rail spacing 2.68" max.] | |
| Steam table pans (12"x20"x1") | 10 |
| Steam table pans (12"x20"x2.5") | 10 |
| Wire shelves, half size (12"x20") | 10 |
| Sheet pans, half size (12"x20") | 10 |
| Frying baskets, half size (12"x20") | 10 |
| Plates (optional plate rack) | 26 |
| Max. loading weight | |
| Per combi oven | 110 lbs |
| Per shelf level | 33 lbs |

Electrical supply

| | |
|---|----------------|
| 208V 3PH 60Hz / 240V 3PH 60Hz * | |
| Rated power consumption | 15.9 / 21.0 kW |
| Rated current | 44.1 / 50.6 A |
| Power supply wire gauge | 6 AWG |
| Conductor insulation rating | 194 °F / 90 °C |
| 440V 3PH 60Hz / 480V 3PH 60Hz * | |
| Rated power consumption | 16.3 / 19.3 kW |
| Rated current | 21.4 / 23.3 A |
| Power supply wire gauge | 8 AWG |
| Conductor insulation rating | 194 °F / 90 °C |
| When using the ConvoSmoke option, the only available voltage options are: | |
| 208V 3PH 60Hz * | |
| Rated power consumption | 15.9 kW |
| Rated current | 44.1 A |
| Power supply wire gauge | 6 AWG |
| Conductor insulation rating | 194 °F / 90 °C |
| 240V 3PH 60Hz * | |
| Rated power consumption | 21.0 kW |
| Rated current | 50.6 A |
| Power supply wire gauge | 6 AWG |
| Conductor insulation rating | 194 °F / 90 °C |

* Prepared for connection to an energy optimizing system.

Water connections

| | |
|---------------------|--|
| Water supply | |
| Water supply | Two 3/4" inner diameter GHT-M (garden hose adapter). The unit is designed for a permanent hookup to the water supply that uses a connecting hose with a minimum diameter of 1/2" |
| Flow pressure | 22 - 87 psi / 1.5 - 6 bar |
| Drain | |
| Drain version | Permanent hookup (recommended) or funnel waste trap |
| Type | 2" inside diameter (comes elbow-shaped as standard) |
| Slope for drainpipe | min. 3.5% (2°) |

Water quality

| | |
|--|---|
| Water connection A* for boiler, Water connection B* for cleaning, recoil hand shower | |
| General requirements | Drinking water, typically untreated water |
| TDS | 70 - 360 ppm |
| Hardness | 70 - 360 ppm (4 - 21 gpg) |
| pH value | 6.5 - 8.5 |
| Cl ⁻ (chloride) | max. 60 ppm |
| Cl ₂ (free chlorine) | max. 0.2 ppm |
| SO ₄ ²⁻ (sulfate) | max. 150 ppm |
| Fe (iron) | max. 0.1 ppm |
| SiO ₂ (silica) | max. 13 ppm |
| NH ₂ Cl (monochloramine) | max. 0.4 ppm |
| Temperature | max. 104°F / max. 40°C |

* See connection positions diagram, p. 2.

NOTICE: The owner/operator/purchaser must ensure that the water quality requirements are met. Otherwise the original equipment warranty is void.

Emissions

| | |
|------------------------|-------------------|
| Heat loss | |
| Latent | 3400 BTU/h |
| Sensitive | 4300 BTU/h |
| Wastewater temperature | max. 140°F / 60°C |
| Decibel rating | max. 70 dBA |

Water consumption

| | |
|-----------------------------------|----------|
| Water connections A, B | |
| Average consumption for cooking** | 1.59 gph |
| Required flow rate | 3.96 gpm |

** Incl. water required for cooling the wastewater.

NOTICE: See connection positions diagram, p. 2.

ACCESSORIES

(For more detailed information, please refer to the Accessories brochure.)

Stacking kit

| | |
|---------------------|---------------|
| Combination allowed | 6.10 on 10.10 |
|---------------------|---------------|

If combining two electrical units

Select the "stacking kit for Convotherm 4 electrical units"

If combining one electrical unit and one gas unit in a stacking kit

Select the "stacking kit for Convotherm 4 electrical units" if:

| | |
|-------------------|-------|
| Bottom combi oven | EB/ES |
| Top combi oven | GB/GS |

Select the "stacking kit for Convotherm 4 gas units" if:

| | |
|-------------------|-------|
| Bottom combi oven | GB/GS |
| Top combi oven | EB/ES |

Equipment stand

| | |
|---------------------------------|--------|
| Standard support surface height | 26.38" |
|---------------------------------|--------|

Please note:

- Please refer to the Installation manual for further technical data and for instructions on installation and setup.
- Convotherm reserves the right of design improvement or modification, as warranted.
- There are numerous federal, national and local laws, regulations and standards. It is the responsibility of the owner and installer to observe these laws, regulations and standards (e.g. fire regulations and health and safety standards).
- Convotherm combi ovens are built to comply with the applicable standards for manufacturers.

9758241_05 ENG_USA 11/18, © 2018 Welbilt. Please note that the product is being continuously improved and that, as a result, these specifications are subject to change without notice.



Combi steamer

Project _____

Item _____

Quantity _____

FCSI section _____

Approval _____

Date _____

C4eT 10.10 ES

Model

Convotherm 4 easyTouch

- easyTouch
- 11 slide rails
- Electrical
- Injection/Spritzer
- Right-hinged door



Key features

- ACS+ operating modes: Steam, combi-steam, hot air
- ACS+ extra functions:
 - Crisp&Tasty - 5 moisture-removal settings
 - BakePro - 5 levels of traditional baking
 - HumidityPro - 5 humidity settings
 - Controllable fan - 5 speed settings
- easyTouch 9" full-touch screen
- ConvoClean+ fully automatic cleaning system with eco, regular and express modes - with optional single-dose dispensing
- Ethernet interface (LAN)
- HygienicCare
- USB port integrated in the control panel
- TriColor indicator ring - indicates the current operating status
- Steam generated by injecting water into the cooking chamber
- Right-hinged door
- KNLZ listed for ventless operation, local codes prevail as in NFPA 96-1994

Standard features

- ACS+ (Advanced Closed System +) operating modes:
 - Steam (86-266°F) with guaranteed steam saturation
 - Combi-steam (86-482°F) with automatic humidity adjustment
 - Hot air (86-482°F) with optimized heat transfer
- HygienicCare - food safety provided by antibacterial surfaces:
 - easyTouch control panel
 - Door handle and recoil hand shower
- easyTouch user interface:
 - 9" full-touch screen
 - Press&Go - automatic cooking with quick-select buttons
 - TrayTimer - oven-load management for different products at the same time
 - Regenerate+ - flexible multi-mode retherm function
 - ecoCooking - energy-save function
 - Low-temperature cooking / Delta-T cooking
 - Cook&Hold - cook and hold in one process
 - 399 cooking profiles each containing up to 20 steps
 - On-screen help with topic-based video function
 - Start-time preset
- Multi-point core temperature probe
- Door handle with safety latch and slam function
- Data storage for HACCP and pasteurization figures
- Preheat and Cool down function

Options

- Steam and vapor removal – built-in condenser (upon request)
- Disappearing door – more space and added safety (see page 2)
- ConvoGrill with grease management function (upon request)
- ConvoSmoke - built in food-smoking
- Marine version (see separate data sheet)
- Available in various voltages
- Sous-vide probe, external connection
- Core temperature probe, external connection

Accessories

- ConvoLink HACCP and cooking-profile management PC software
- Signal tower - indicates the operating status from a distance
- Banquet system (optionally as a package or individually): Plate rack, mobile shelf rack, transport trolley, thermal cover
- Equipment stands in various sizes and designs
- Racks for cooking and baking
- Stacking kits
- Cleaning products for the fully automatic ConvoClean+ cleaning system and the semi-automatic cleaning system

Commercial combination oven with integral systems for limiting the emissions of grease laden air

This product conforms to the ventless operation recommendations set forth by NFPA96 using EPA202 test method



Front view

(disappearing door optional)

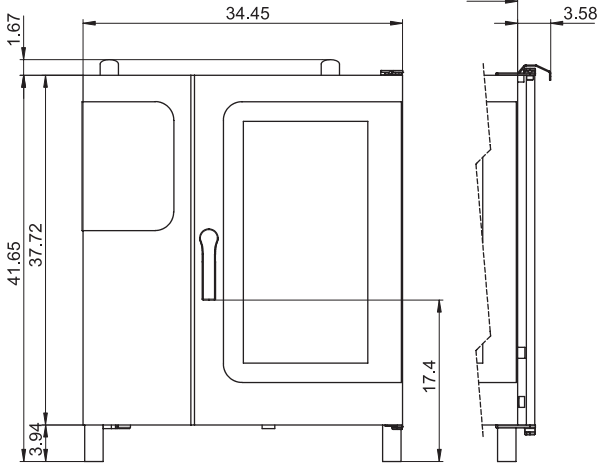

Connection positions

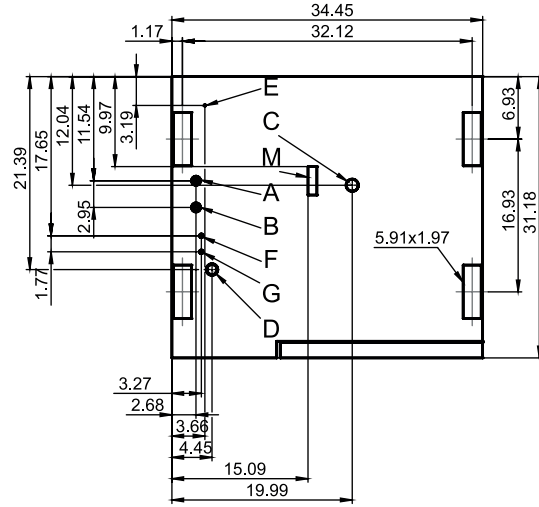

View from above with wall clearances

(disappearing door optional)

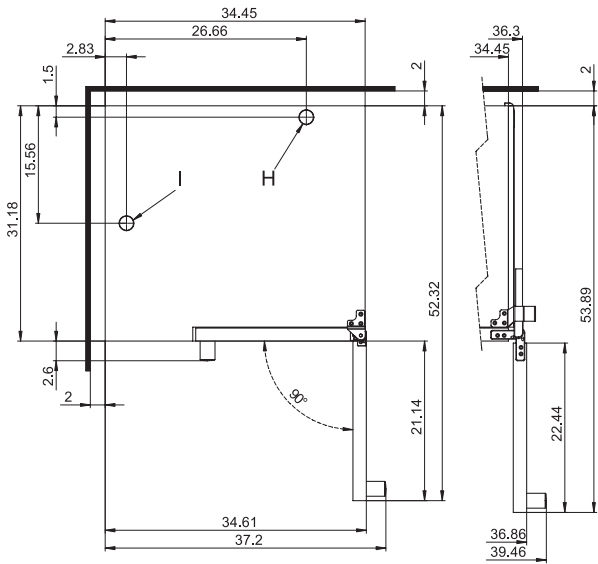

- A** Water connections (for water injection)
- B** Water connections (for cleaning, recoil hand shower)
- C** Drain connection (2" I. D.)
- D** Electrical connection
- E** Electrical ground
- F** Rinse-aid connection
- G** Cleaning-agent connection
- H** Air vent (2" I. D.)
- I** Ventilation port
- M** Safety overflow 3.2" x 1"

Dimensions and weights

Dimensions including packaging

Width x Height x Depth 43.3" x 50.4" x 37"

Weight

Net weight without options* / accessories 289 lbs

Packaging weight 66 lbs

Safety clearances**

| | |
|--|-----|
| Rear | 2" |
| Right (right-hinged door) | 2" |
| Right (disappearing door pushed back) | 5" |
| Left (18" clearance recommended for service) | 2" |
| Top*** | 20" |

* Max. weight of options: 46 lbs.

** Minimum clearance from heat sources: 20".

*** Depends on the type of exhaust system and the ceiling's characteristics.

Installation requirements

Max. absolute appliance inclination during operation* max. 2° (3.4%)

* Adjustable appliance feet as standard.

Loading capacity

Max. number of food containers

[Unit has 11 slide rails; rail spacing 2.68" max.]

| | |
|-------------------------------------|----|
| Steam table pans (12"x20"x1") | 10 |
| Steam table pans (12"x20"x2.5") | 10 |
| Wire shelves, half size (12"x20") | 10 |
| Sheet pans, half size (12"x20") | 10 |
| Frying baskets, half size (12"x20") | 10 |
| Plates (optional plate rack) | 26 |

Max. loading weight

| | |
|-------------------|---------|
| Per combi steamer | 110 lbs |
| Per shelf level | 33 lbs |

Electrical supply

208V 3PH 60Hz / 240V 3PH 60Hz *

| | |
|-----------------------------|----------------|
| Rated power consumption | 15.9 / 21.0 kW |
| Rated current | 44.1 / 50.6 A |
| Power supply wire gauge | 6 AWG |
| Conductor insulation rating | 194°F / 90°C |

440V 3PH 60Hz / 480V 3PH 60Hz *

| | |
|-----------------------------|----------------|
| Rated power consumption | 16.3 / 19.3 kW |
| Rated current | 21.4 / 23.3 A |
| Power supply wire gauge | 8 AWG |
| Conductor insulation rating | 194°F / 90°C |

When using the ConvoSmoke option, the only available voltage options are:

208V 3PH 60Hz *

| | |
|-----------------------------|--------------|
| Rated power consumption | 15.9 kW |
| Rated current | 44.1 A |
| Power supply wire gauge | 6 AWG |
| Conductor insulation rating | 194°F / 90°C |

240V 3PH 60Hz *

| | |
|-----------------------------|--------------|
| Rated power consumption | 21.0 kW |
| Rated current | 50.6 A |
| Power supply wire gauge | 6 AWG |
| Conductor insulation rating | 194°F / 90°C |

* Prepared for connection to an energy optimizing system.

Water connections

Water supply

| | |
|---------------|--|
| Water supply | Two 3/4" I. D. GHT-M (garden hose adapter). The appliance is designed for a permanent hookup to the water supply that uses a connecting hose with a minimum diameter of 1/2" |
| Flow pressure | 22 - 87 PSI / 1.5 - 6 bar |

Drain

| | |
|---------------------|---|
| Drain version | Permanent hookup (recommended) or funnel waste trap |
| Type | 2" I. D. (comes elbow-shaped as standard) |
| Slope for drainpipe | min. 3.5% (2°) |

Water quality

Water connection A* for water injection

| | |
|----------------------|---|
| General requirements | Drinking water, typically treated water (install a water treatment system if necessary) |
| TDS | 70 - 125 ppm |
| Hardness | 70 - 125 ppm (4 - 7 gpg) |

Water connection B* for cleaning, recoil hand shower

| | |
|----------------------|---|
| General requirements | Drinking water, typically untreated water |
| TDS | 70 - 360 ppm |
| Hardness | 70 - 360 ppm (4 - 21 gpg) |

Water connections A, B*

| | |
|---|------------------------|
| pH value | 6.5 - 8.5 |
| Cl ⁻ (chloride) | max. 60 ppm |
| Cl ₂ (free chlorine) | max. 0.2 ppm |
| SO ₄ ²⁻ (sulfate) | max. 150 ppm |
| Fe (iron) | max. 0.1 ppm |
| SiO ₂ (silica) | max. 13 ppm |
| NH ₂ Cl (monochloramine) | max. 0.4 ppm |
| Temperature | max. 104°F / max. 40°C |

* See connection positions diagram, p. 2.

NOTICE: The owner/operator/purchaser must ensure that the water quality requirements are met. Otherwise the original equipment warranty is void.

Emissions

Heat emission

| | |
|-----------|------------|
| Latent | 3400 BTU/h |
| Sensitive | 4300 BTU/h |

| | |
|--------------------------|-------------------|
| Drain temperature | max. 140°F / 60°C |
|--------------------------|-------------------|

| | |
|-----------------------|-------------|
| Decibel rating | max. 70 dBA |
|-----------------------|-------------|

Water consumption

Water connection A*

| | |
|---------------------------------|----------|
| Average consumption for cooking | 1.11 gph |
| Required flow rate | 0.16 gpm |

Water connections A, B

| | |
|-----------------------------------|----------|
| Average consumption for cooking** | 1.66 gph |
| Required flow rate | 3.96 gpm |

* Values intended as guide for specifying the water treatment system.

** Incl. water required for cooling the wastewater.

NOTICE: See connection positions diagram, p. 2.

Please note:

- Please refer to the Installation manual for further technical data and for instructions on installation and setup.
- Convotherm reserves the right of design improvement or modification, as warranted.
- There are numerous federal, national and local laws, regulations and standards. It is the responsibility of the owner and installer to observe these laws, regulations and standards (e.g. fire regulations and health and safety standards).
- Convotherm combi steamers are built to comply with the applicable standards for manufacturers.

ACCESSORIES

(For more detailed information, please refer to the Accessories brochure.)

Stacking kit

| | |
|---------------------|---------------|
| Combination allowed | 6.10 on 10.10 |
|---------------------|---------------|

If combining two electrical units

Select the "stacking kit for Convotherm 4 electrical units"

If combining one electrical unit and one gas unit in a stacking kit

Select the "stacking kit for Convotherm 4 electrical units" if:

| | |
|----------------------|-------|
| Bottom combi steamer | EB/ES |
| Top combi steamer | GB/GS |

Select the "stacking kit for Convotherm 4 gas units" if:

| | |
|----------------------|-------|
| Bottom combi steamer | GB/GS |
| Top combi steamer | EB/ES |

Equipment stand

| | |
|---------------------------------|--------|
| Standard support surface height | 26.38" |
|---------------------------------|--------|