

SERVING THE FOOD INDUSTRY SINCE 1951



## Aurora Undercounter Freezers

ITEM:  
MODEL:

59053  
FR-CN-0686E-HC

59092  
FR-CN-1529E-HC



59053  
FR-CN-0686E-HC



59092  
FR-CN-1529E-HC

**The perfect solution to add cold storage space for frozen products and ingredients conveniently within reach.**

**FEATURES:**

- Stainless steel interior and exterior
- Refrigeration system keeps food at safe
- Self-closing doors with 90 degree stayopen feature
- Adjustable heavy-duty PVC coated shelves
- Digital control system makes it easy to adjust temperature set point and defrost frequency
- Hydro-carbon R290 refrigerant, which is environmentally friendly and more efficient

Telephone: 1-800-465-0234

Fax: (905) 607-0234

Email: sales@omcan.com

Website: www.omcan.com



Authorized Dealer

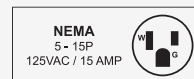
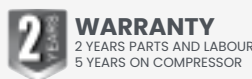

## TECHNICAL DRAWING

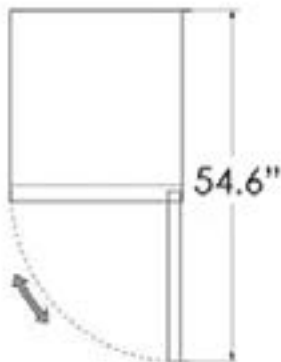
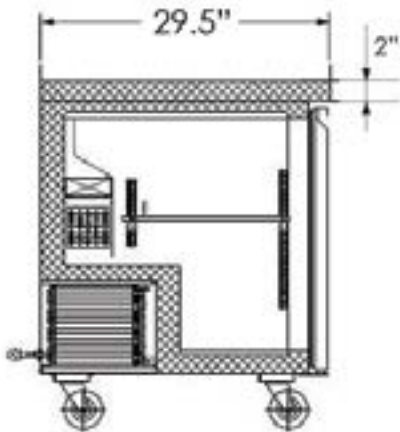
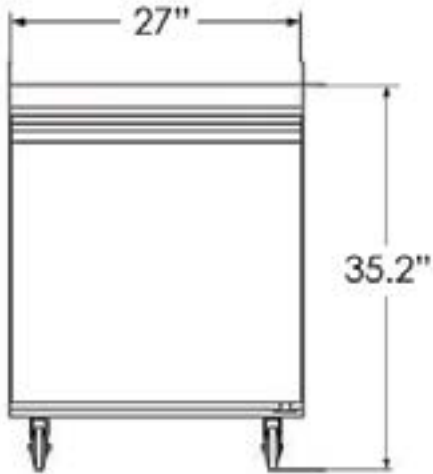

## TECHNICAL SPECIFICATION

Item	59053
Model	FR-CN-0686E-HC
Capacity	6.3 cu.ft. / 177 L
Number of Doors	1 Solid Door
Number of Shelves	1
Shelf Capacity (kg/pc)	44 lb. / 20 kg.
Shelf Material	Coated Steel
Self-closing Door	Yes
Power	1/6 HP
Amps	1.9 A
Electrical	115V / 60Hz / 1Ph
Temperature Controller	Mechanical / Digital Display
Temperature Range	-18 to -22°C / -0 to -8°F
Refrigerant	R290
Insulation Material	Cyclopentane
Cooling System	Ventilated
Defrosting	Automatic
Interior Dimensions (WDH)	22.2" x 22.8" x 23.5" / 565 x 580 x 597 mm
Net Weight	169lb. / 77 kg.
Net Dimensions (WDH)	27" x 29.5" x 35.2" / 685 x 750 x 895 mm
Gross Weight	220 lb. / 100 kg.
Gross Dimensions (WDH)	30.4" x 32.6" x 38.6" / 770 x 830 x 980 mm
Plug Type	NEMA 5-15P

## TECHNICAL DRAWING

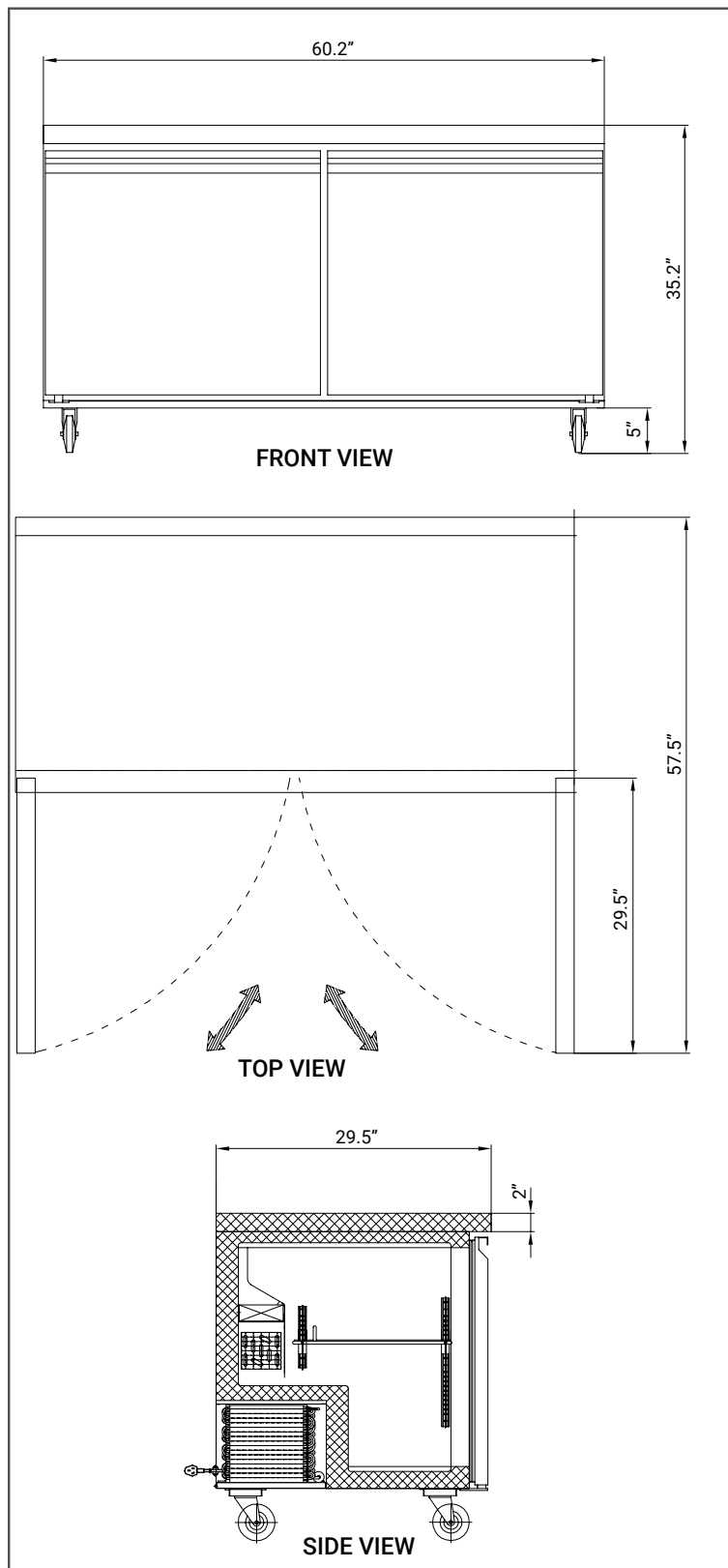

## TECHNICAL SPECIFICATION

Item	59092
Model	FR-CN-1529E-HC
Capacity	15 cu. ft. / 425 L
Number of Doors	2 Solid Doors
Number of Shelves	2
Shelf Capacity (kg/pc)	88lb. / 40kg.
Shelf Material	Plastic Coated
Self-closing Door	Yes
Power	345 W
Amps	4.5 A
Electrical	115V / 60Hz / 1Ph
Temperature Controller	-18 to -22°C / -0 to -8°F
Temperature Range	Digital Display
Refrigerant	R290
Insulation Material	Cyclopentane
Cooling System	Ventilated
Defrosting	Automatic
Interior Dimensions (WDH)	55.6" X 19.84" X 23.5" / 1413 X 504 X 597 mm
Net Weight	254 lb. / 115 kg.
Net Dimensions (WDH)	60.2" X 29.5" X 38.8" / 1529 X 750 X 985 mm
Gross Weight	324 lb. / 147 kg.
Gross Dimensions (WDH)	74.2" x 32.3" x 38.2" / 1600 x 820 x 970 mm
Plug Type	NEMA 5-15P

This equipment is intended for use in an indoor environment where ambient temperature and humidity do not exceed 24°C / 75°F and 55% relative humidity.