

AMERICAN RANGE®

A  Company

Project _____

Item # _____

Quantity _____

HIGH EFFICIENCY FRYERS

GAS TYPE: NATURAL LP



AF-50HE

STANDARD FEATURES

- All stainless steel front and sides.
- Heavy gauge stainless steel tank.
- Energy efficient burners rated at 75,000 BTU/hr. each.
- Millivolt control system with 100% safety shut off.
- Thermostatic control with 200°F to 400°F range.
- 1-1/4" full port drain valve.
- 4" legs or optional casters.
- Two year limited warranty, parts and labor.

AVAILABLE OPTIONS

- Stainless steel tank cover.
- Four casters front two with locking brakes.
- Matching "Dump Station."
- Stainless steel Splash Guard (easily removable without tools).
- Stainless steel side tray for working surface or dump station, can be used with optional heat lamp.
- Stainless steel spreader work top solid surface 12", 18" and 24".
- Quick disconnect and flexible gas hose.
- Joiner Strip: Connects two fryers and prevents oil from getting in between the fryers or drain station.



Model Shown AF-50HE

Shown with optional casters

DESCRIPTION

American Range, Energy Star® fryer 50 pound fryer, model AF-50HE. All stainless steel front and sides, with heavy gauge stainless steel tank and rated at 75,000 BTU/hr. Standard Millivolt control system with 100% safety shut off and Thermostatic control with a temperature range of 200°F to 400°F. 1-1/4" full port drain valve for easy cleaning.



DESIGNED & BUILT IN USA
PROFESSIONAL COOKING EQUIPMENT

AMERICAN RANGE®

A  Company

13592 Desmond St Pacoima CA 91331
T. 818.897.0808 Toll Free: 888.753.9898
www.AmericanRange.com

HIGH EFFICIENCY FRYERS

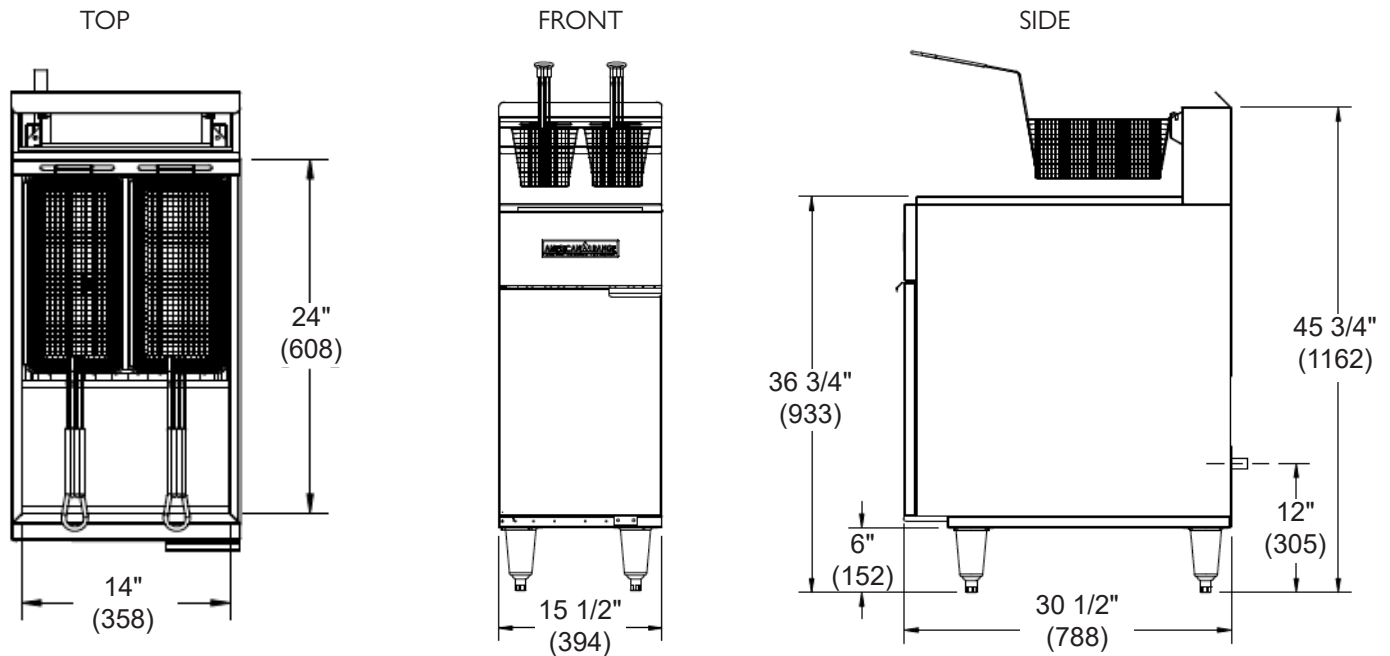

MODEL	WIDTH (MM)	DEPTH (MM)	HEIGHT (MM)	BURNERS	BTU	(KW)	Shipping Weight*	
							LBS	(KG)
AF-50HE	15 1/2" (394)	30-1/2" (788)	45-3/4" (1162)	3	75,000	(22)	150	(68)

Specify type of gas and altitude if over 2000 feet.

Please specify gas type when ordering.

NATURAL GAS	MANIFOLD PRESSURE	
	PROPANE GAS	MANIFOLD SIZE
5.0" W.C.	10.0" W.C.	3/4" (19MM)

NMFCODE: 25970-2 Class: 85

*Shipping weight includes packaging and is approximate.

American Range is a quality manufacturer of commercial cooking equipment. Due to continuing product improvements, these specifications are subject to change without prior notice.

COMBUSTIBLE WALL CLEARANCES:

For use only on non-combustible floors. Legs or casters are required, or 2" (51) overhang is required when curb mounted. Clearance from non-combustible walls is 0". When unit is placed next to combustible walls, clearances must exceed 12" (305) from sides, and 4" (102) from rear.

Commercial cooking equipment requires an adequate ventilation system. For additional information, refer to the National Fire Protection Association's standard.

NFPA96 "Vapor Removal from Cooking Equipment." (NOTE: For North America only)



A70612 RevB 04192023



13592 Desmond St Pacoima CA 91331
T. 818.897.0808 Toll Free: 888.753.9898
www.AmericanRange.com