



®

Simply Engineered Better

601HTG

Undercounter High Temperature Glasswasher with Built-in Booster



37-1/4"
(946mm)

SPECIFIER STATEMENT

Specified unit will be Moyer Diebel Model 601HTG undercounter high temperature glasswasher with built-in booster.

Features include 12-1/8" door opening, standard detergent and rinse-aid dispensing pumps. Built-in 6KW rise booster, and wash tank heater. Stainless steel, type 316 wash tank.

1 year parts and wash tank warranty.

Project _____

Item No. _____

Quantity _____

STANDARD FEATURES

- **Back saving**, practical, 22-1/2" [572] loading height
- **Soft Start**, protects glasses and mugs from chipping and breaking
- **Industry exclusive**, deep drawn, type 316 stainless steel tank
- **12-1/8" [308] door opening**, ideal for racked glasses
- Heavy duty cycle provides versatility for heavily soiled glassware
- Dedicated rinse arms for sparkling results
- Delime feature allows easy delimiting of wash cavity
- Auto-clean flushes tank interior at end of serving period
- Rinse- Sentry ensures 180°F final rinse
- Microprocessor controls and digital temperature displays
- Pumped drain provides for easy installation
- Counter- balanced door
- Multi-Power, allows for easy field conversion to three phase
- Built-in booster for 180°F final rinse
- Advanced service diagnostics
- Two 20"x20" racks, one peg, one flat

601HTG HIGH TEMPERATURE GLASSWASHER



OPTIONS & ACCESSORIES

- | | |
|-------------------------------------------------------------------------|---------------|
| <input type="checkbox"/> 9kW booster | P/N 0708757 |
| <input type="checkbox"/> Flat bottom dishrack | P/N 101273 |
| <input type="checkbox"/> Peg dishrack | P/N 101285 |
| <input type="checkbox"/> 17RS - 17" Stand | P/N 0708757 |
| <input type="checkbox"/> Drain Water Tempering Kit (factory installed) | P/N 0712383-1 |
| <input type="checkbox"/> Low Chemical Alarm (factory installed) | P/N 0712314 |
| <input type="checkbox"/> PRV - Pressure regulating valve | P/N 108265 |
| <input type="checkbox"/> 4" stand converts to a standard counter height | |

Moyer Diebel Ltd. - Canada

2674 North Service Rd., Jordan Station, Ontario, Canada L0R 1S0 Tel: 800/263-5798 Fax: 905/562-5422

sales@moyerdiebellimited.com

www.championindustries.com/1canada



Simply Engineered Better

601HTG

Undercounter
High Temperature Glasswasher

Dimensions shown in inches and [millimeters]

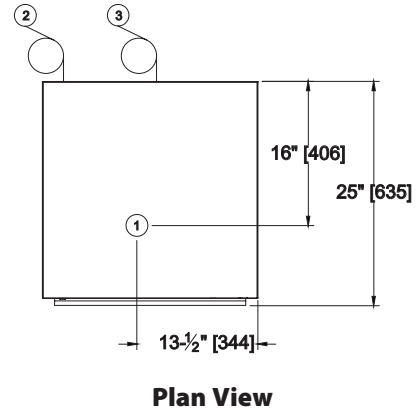
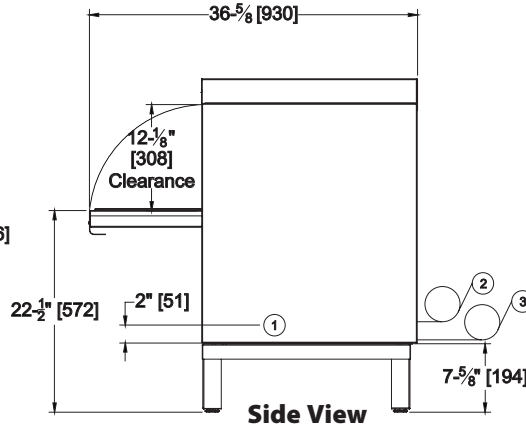
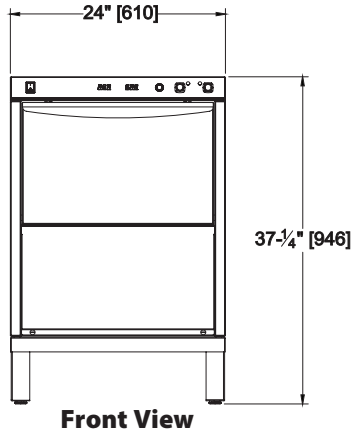

SPECIFICATIONS	
Capacity	
*Racks per hr.	40
Motor Horsepower	
Wash	1
Water Consumption	
Imp. gal./liters per hr. (max. use)	23.4/19.2
Imp. gal./liters per rack	0.78/0.64
Temperatures °F/°C	
Wash (minimum)	150/66
Rinse (minimum)	180/82
Heating	
Tank heat, electric (kW)	2
Electric booster (kW required for 40-70°F rise)	6
(kW required for true 70°F rise)	9
Time Cycle in Seconds	
Wash	70
Rinse	14
Dwell	6
Total cycle	90

* Excludes 30 second NSF load/unload time

Warning: Plumbing and electrical connections should be made by qualified personnel who will observe all the applicable plumbing, sanitary and safety codes.

Due to an ongoing value analysis program at Moyer Diebel, specifications in this catalog are subject to change without notice.

Utilities

1 Electrical Connection	115/208-240/60/1; 3 wire plus ground. Hard wiring required (see box) 115/208-240/60/3; 4 wire plus ground.
2 Water Connection	140°F Min., hot water for 6kW rise booster. 110°F Min., hot water for 9kW rise booster. 5 ft. long 1/2" I.D. flexible fill hose with 3/4" garden hose connection provided. Flow pressure: 25-95 psi
3 Drain Connection	5 ft. long, 5/8" I.D. flexible drain hose provided. For Y connection into 1-1/2" drain. Max. drain flow: 7 US gpm.; maximum 3' height above floor

601HTG with 6kW Rise Booster

Electrical Specs.	Rated Amps	Minimum Supply Ckt. Conductor Ampacity	Maximum Overcurrent Protective Device
208/60/1	32	40	40
240/60/1	36	40	40
208/60/3	22	30	30
240/60/3	24	30	30

601HTG with 9kW Rise Booster

Electrical Specs.	Rated Amps	Minimum Supply Ckt. Conductor Ampacity	Maximum Overcurrent Protective Device
208/60/1	45	60	60
240/60/1	50	60	60
208/60/3	29	35	35
240/60/3	33	40	30

	Uncrated	Crated
Height*	33-3/4" [860]	39-1/2" [1003]
Width	24" [610]	25" [635]
Depth	24" [610]	25-1/2" [647]
Ship Wt. lbs/kg	178/79	198/90

* Front leveling feet provided.

***Note:** Electrical supply service must be a 3 or 4 wire plus ground for connection as shown.

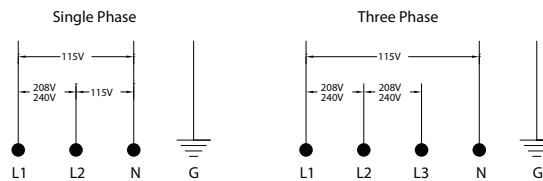

an Ali Group Company

