



HANDLING AND STORAGE

SERVING THE FOOD INDUSTRY SINCE 1951

GALVANIZED STOCKING CART

Item: 45588



This Omcán stocking cart is sturdily constructed to endure tough everyday handling; able to hold 300kgs. The compact design of this cart is beneficial for reducing crowding and to easily be put back into storage. This stock cart is great for supermarkets and various food service operations; it is guaranteed to last throughout long transporting operations with the utmost efficiency.



WARRANTY



Authorized Dealer

HANDLING AND STORAGE GALVANIZED STOCKING CART



DIMENSIONS

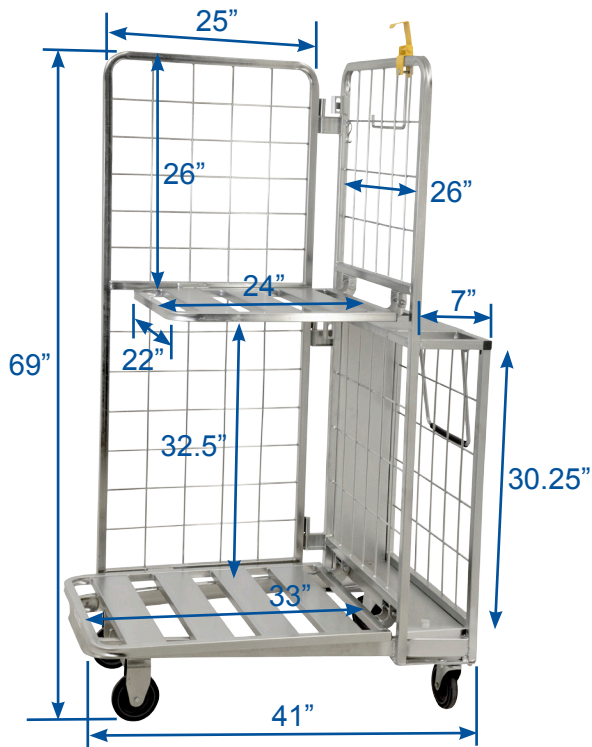

Features:

- It's constructed with a hook, pull handle, paper towel holder and cardboard holder.
- The 2 fixed front casters and 2 swivel rear casters swivel easily, allowing the user to push the cart with ease and maneuver in all directions.

TECHNICAL SPECIFICATION

ITEM NUMBER	45588
MATERIAL	Galvanized steel
MAXIMUM LOADING WEIGHT	300 kg/ 661 lbs
DIMENSIONS	26" x 41" x 69"/ 660 x 1041 x 1752.6 mm
NET WEIGHT	44.6 kg/ 98 lbs
GROSS WEIGHT	46.6 kg/ 102.7 lbs



OMCAN INC.

Telephone: 1-800-465-0234
 Fax: (905) 607-0234
 Email: sales@omcan.com
 Website: www.omcan.com



Follow us to keep up to date with the latest news and offers



2017E&OE