



FOOD EQUIPMENT

SERVING THE FOOD INDUSTRY SINCE 1951

49-INCH OUTDOOR PROPANE BARBECUE WITH 4 BURNERS

Item: 44491 | Model: CE-CN-0060-S



ENJOY COOKING AND GRILLING YOUR SIGNATURE MEATS, KEBABS, AND VEGETABLES OUTSIDE WITH OMCAN'S OUTDOOR BBQ GRILLS!

Perfect for country clubs, resorts, hotels, and catering events, Omcan's outdoor propane barbecue grill has 4 burners - outputting 15,000 BTU each, and is constructed with durable stainless steel construction. This barbecue grill is also made portable by (2) 14" wheels and (2) lockable 5" casters which allows easy transitions to places. Easy to use and clean.



WARRANTY
PARTS AND LABOR



Authorized Dealer

FOOD EQUIPMENT

49-INCH OUTDOOR PROPANE BARBECUE - 4 BURNERS



FEATURES

- (4) burners; total of 60,000 BTU
- Durable stainless steel construction:
 - » 430 stainless steel cooking grids
 - » 304 stainless steel tube burners, control panel, body, bottom board and side shelf
 - » Lid is made of 14 gauge 304 stainless steel hood, edge polishing
 - » Knobs are made of ABS and stainless steel
- Equipped with (2) 14" wheels and (2) lockable 5" casters

OPTIONAL ACCESSORY *(Item sold separately)*

ITEM NUMBER	44700
DESCRIPTION	Stainless Steel Side Shelf for item 44491 / 44492 BBQ Grills

TECHNICAL SPECIFICATIONS

ITEM NUMBER	44491
MODEL	CE-CN-0060-S
BURNERS	4
GAS TYPE	Propane
PROPANE TANK CAPACITY	30 lbs.
TOTAL BTU	60,000 BTU (15,000 BTU per burner)
PRE-HEAT TIME	5 minutes
COOKING AREA	27.8" x 21.3" / 706.12 x 541.02 mm
DIMENSIONS (WDH)	49.21" x 30.91" x 49.61" / 1250 x 785 x 1260 mm
GROSS DIMENSIONS	35" x 26" x 19" / 889 x 660.4 x 482.6 mm
NET WEIGHT	196 lbs. / 88.9 kg.
GROSS WEIGHT	218 lbs. / 98.9 kg.

TECHNICAL DRAWINGS WITH DETAILED DIMENSIONS

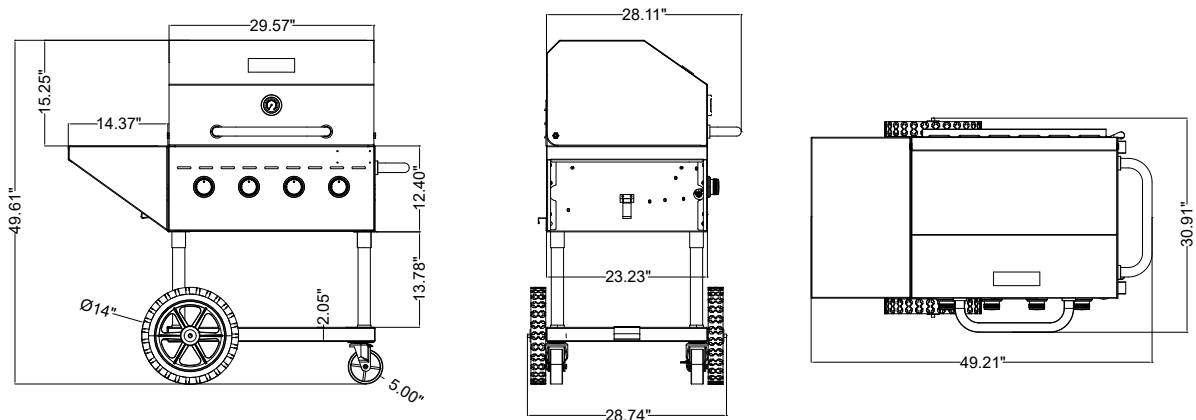

OMCAN INC.

Telephone: 1-800-465-0234
 Fax: (905) 607-0234
 Email: sales@omcan.com
 Website: www.omcan.com



Follow us to keep up to date with the latest news and offers





FOOD EQUIPMENT

SERVING THE FOOD INDUSTRY SINCE 1951

80-INCH OUTDOOR PROPANE BARBECUE WITH 8 BURNERS

Item: 44492 | Model: CE-CN-0120-D



ENJOY COOKING AND GRILLING YOUR SIGNATURE MEATS, KEBABS, AND VEGETABLES OUTSIDE WITH OMCAN'S OUTDOOR BBQ GRILLS!

Perfect for country clubs, resorts, hotels, and catering events, Omcan's outdoor propane barbecue grill has 8 burners - outputting 15,000 BTU each, and is constructed with durable stainless steel construction.

This bbq grill is also made portable by (2) 14" wheels and (2) lockable 5" casters which allows easy transitions to places. Easy to use and clean.



WARRANTY
PARTS AND LABOR



Authorized Dealer

FOOD EQUIPMENT

80-INCH OUTDOOR PROPANE BARBECUE - 8 BURNERS



FEATURES

- (8) burners; total of 120,000 BTU
- Durable stainless steel construction:
 - » 430 stainless steel cooking grids
 - » 304 stainless steel tube burners, control panel, body, bottom board and side shelf
 - » Lid is made of 14 gauge 304 stainless steel hood, edge polishing
 - » Knobs are made of ABS and stainless steel
- Equipped with (2) 14" wheels and (2) lockable 5" casters

OPTIONAL ACCESSORY *(Item sold separately)*

ITEM NUMBER

44700

DESCRIPTION

Stainless Steel Side Shelf for item 44491 / 44492 BBQ Grills

TECHNICAL SPECIFICATIONS

ITEM NUMBER

44492

MODEL

CE-CN-0120-D

BURNERS

8

GAS TYPE

Propane

PROPANE TANK CAPACITY

30 lbs. (x2)

TOTAL BTU

120,000 BTU (15,000 BTU per burner)

PRE-HEAT TIME

5 minutes

COOKING AREA

(x2) 27.8" x 21.3" / 706.12 x 541.02 mm

DIMENSIONS (WDH)

80.31" x 30.91" x 49.61" / 2040 x 785 x 1260 mm

GROSS DIMENSIONS

70" x 26" x 19" / 1778 x 660.4 x 482.6 mm

NET WEIGHT

340 lbs. / 154.2 kg.

GROSS WEIGHT

385 lbs. / 174.6 kg.

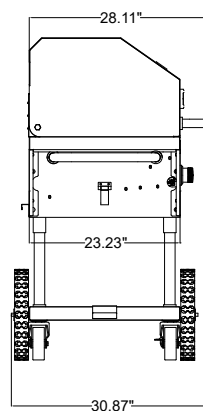
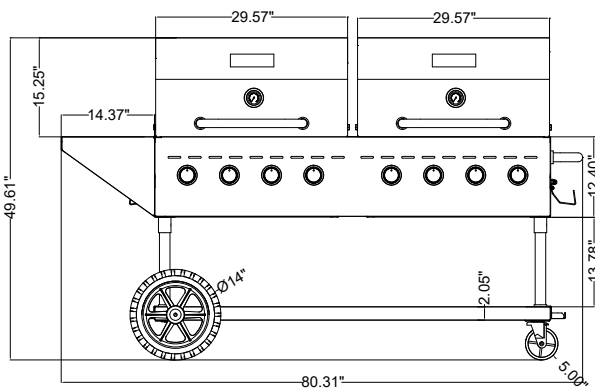

TECHNICAL DRAWINGS WITH DETAILED DIMENSIONS

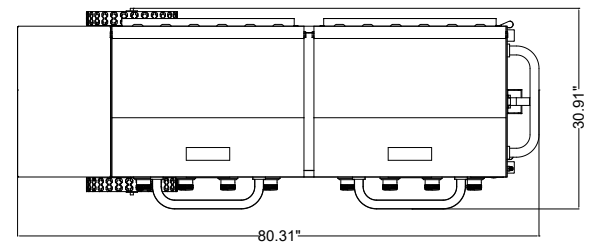

OMCAN INC.

Telephone: 1-800-465-0234

Fax: (905) 607-0234

Email: sales@omcan.com

Website: www.omcan.com



Follow us to keep up to date with the latest news and offers



2019.E&OE