



REFRIGERATION

SERVING THE FOOD INDUSTRY SINCE 1951

26-INCH REFRIGERATED DISPLAY CASE

Item: 44379 Model: RS-CN-0186

**Keep your products cool
and fresh all day long!**

Illuminate your products with this open refrigerated floor display case. Watch your products come to life in front of your customers with brilliant LED lighting and convenient pull-down curtain to ensure product freshness. This unit includes a digital temperature controller to customize all your settings! Bring this refrigerated floor display case to your convenience store, deli, bakery, restaurant, and start showcasing your products the right way to increase impulse sales!



WARRANTY
PARTS AND LABOR



Authorized Dealer

REFRIGERATION

26-INCH REFRIGERATED DISPLAY CASE



Item 44379 - Refrigerated Showcase with pull-down curtain



Features:

- Brilliant Internal LED illumination on sides
- Digital temperature controller and display
- Includes a durable night curtain
- Water tray can be connected with drain pipe
- 4 Casters with 2 breaks
- Stainless steel louver
- Ventilated cooling system
- Automatic defrost
- Condensation water evaporated automatically

TECHNICAL DRAWINGS WITH DETAILED DIMENSIONS

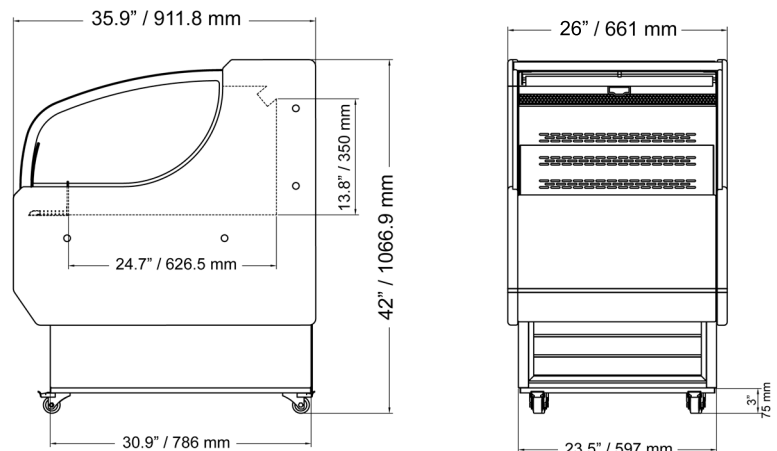

TECHNICAL SPECIFICATIONS

| | | | |
|----------------------------|----------------------|----------------------|--|
| ITEM NUMBER | 44379 | LAMP POWER (W) | 2.6W |
| MODEL | RS-CN-0186 | NO. OF SHELVES | 1 |
| CAPACITY | 186L / 6.6 cu.ft | ELECTRICAL | 110V / 60Hz / 1Ph |
| COMPRESSOR POWER | 3/4HP | NET DIMENSIONS (WDH) | 26" x 35.9" x 42" 661 x 911.8 x 1066.9 mm |
| RATED CURRENT (AMPS) | 11.6A | GROSS DIMENSIONS | 29.5" x 39" x 47.6" 750 x 995 x 1210 mm |
| REFRIGERANT | R404a | NEW WEIGHT | 198.4 LBS. / 90 KG. |
| TEMPERATURE RANGE | 2 - 10°C / 35 - 50°F | GROSS WEIGHT | 253.5 LBS. / 115 KG. |
| ELECTRICAL HEATING ELEMENT | 450W | | |

OMCAN INC.

Telephone: 1-800-465-0234
 Fax: (905) 607-0234
 Email: sales@omcan.com
 Website: www.omcan.com



Follow us to keep up to date with the latest news and offers

