



SERVING THE FOOD INDUSTRY SINCE 1951

HEAVY-DUTY 20-QT BAKING MIXER WITH TIMER AND GUARD

Item: 43560 Model: MX-CN-0020

Designed with an overload protection to effectively guarantee long-life service. Heat is spread in axial direction. These units are equipped with a #12 drive hub.



WARRANTY

PARTS AND LABOR

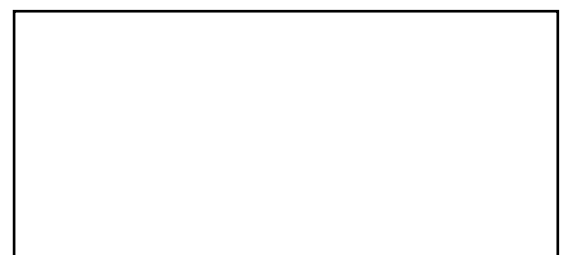

Authorized Dealer

KITCHEN EQUIPMENT

HEAVY-DUTY 20-QT BAKING MIXER WITH TIMER AND GUARD



Upgraded gear drives for maximum strength and efficiency. Comes with a heavy-duty 2-HP motor. The unit is also equipped with a guard and timer. Stainless steel bowl, wire whip, flat beater and hook included.

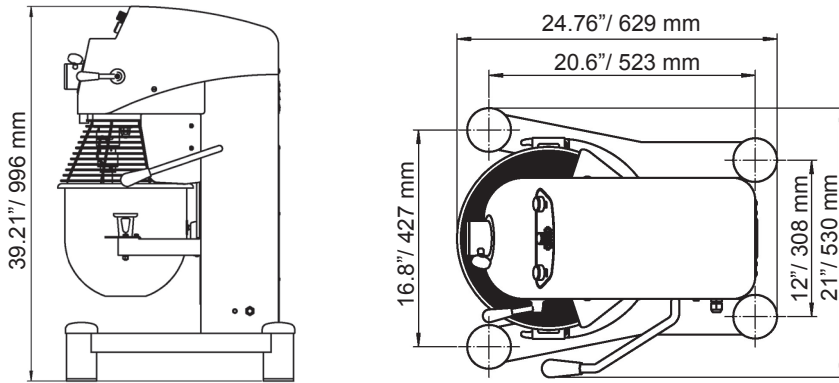

Control panel



Accessories included

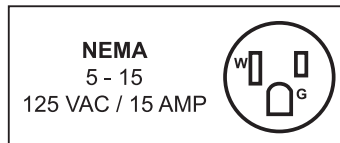

TECHNICAL SPECIFICATION

ITEM NUMBER	43560		
MODEL	MX-CN-0020		
POWER	2 HP / 1.5 kW		
CAPACITY	20 QT		
SHAFT SPEED (R/MIN)	97-120 First Speed	220-271 Second Speed	316-389 Third Speed
TIMER	Yes		
GUARD	Yes		
ELECTRICAL	110 V / 60Hz / 1		
PACKAGING WEIGHT	275 lbs. / 125 kg.		
DIMENSIONS (DWH)	24.76" x 16.18" x 39.21" / 629 x 427 x 996 mm		
PACKAGING DIMENSIONS	25" x 29" x 44" / 635 x 737 x 1117.6 mm		

ACCESSORIES

ITEM NUMBER	DESCRIPTION
25727	Stainless Steel Bowl
43521	Stainless Steel Wire Whip
43522	Stainless Steel Flat Beater
43523	Stainless Steel Hook

OMCAN INC.

Telephone: 1-800-465-0234
 Fax: (905) 607-0234
 Email: sales@omcan.com
 Website: www.omcan.com



Follow us to keep up to date with the latest news and offers

