



# REFRIGERATION

SERVING THE FOOD INDUSTRY SINCE 1951

## 49-INCH ICE CREAM DISPLAY SHOWCASE

Item: 43118 Model: FR-CN-1200-D



SERVE AND DISPLAY MOUTHWATERING  
ICE CREAM, GELATO, AND SORBETS

### STANDARD FEATURES

- Brilliant Internal LED lights
- Digital temperature controller and display
- Ventilated cooling system
- Automatic defrost
- 4 casters with 2 brakes
- Comes with 12 quarter-size pans



**WARRANTY**  
PARTS AND LABOR



NEMA  
6 - 15  
250 VAC / 15 AMP



Authorized Dealer

# REFRIGERATION

## 49-INCH ICE CREAM DISPLAY SHOWCASE



### TECHNICAL SPECIFICATIONS

ITEM NUMBER	43118
MODEL	FR-CN-1200-D
STORAGE VOLUME	600 L
TEMPERATURE RANGE	-18° - -24°C / -0.4° - -11.2°F
GENERAL RATED INPUT POWER	0.65 kW
DEFROST POWER	1.05 kW
RATED CURRENT	4.6A
FOAMING AGENT	C5H10
REFRIGERANT & INJECTION	R404 & 310g
TYPE OF CLIMATE	4
LAMP POWER	6 Watts (LED)
ELECTRICAL	220V / 60Hz / 1Ph
NET WEIGHT	542.3 lbs. / 246 kg.
GROSS WEIGHT	630.5 lbs. / 286 kg.
NET DIMENSIONS (DWH)	41.9" x 48.8" x 55.5" 1065 x 1240 x 1410 mm
GROSS DIMENSIONS	51.6" x 45" x 61.8" 1310 x 1145 x 1570 mm

### PRODUCT DETAILS



Comes with 12 Quarter-size Pans



Ice Cream Display with Lights On  
• 2 LED Lights (6 Watts each)



Efficient sliding door at the back for easy access

### TECHNICAL DRAWINGS AND DIMENSIONS

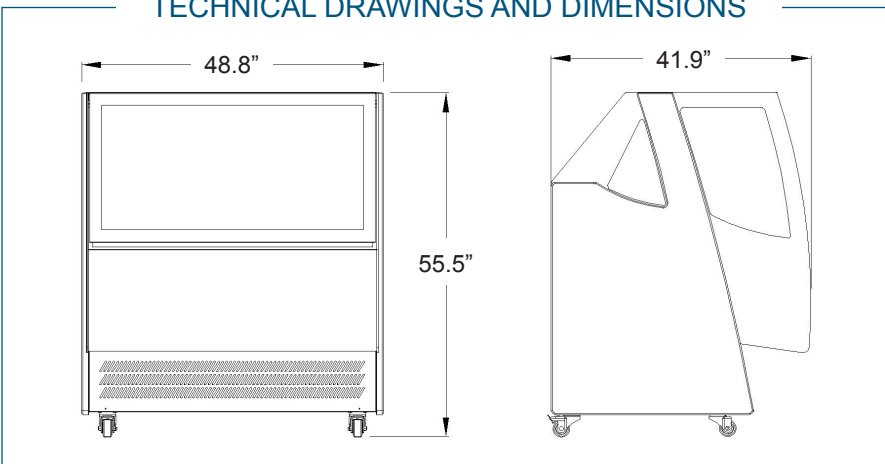

**WARRANTY**  
PARTS AND LABOR

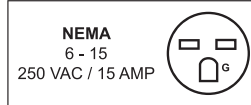

**OMCAN INC.**

Telephone: 1-800-465-0234  
Fax: (905) 607-0234  
Email: sales@omcan.com  
Website: www.omcan.com



Follow us to keep up to date with the latest news and offers

