



COUNTERTOP MERCHANDISER

SERVING THE FOOD INDUSTRY SINCE 1951

35L & 50L CAPACITY DISPLAY WARMERS

Item: 41869
Model: DW-CN-0035

Item: 41871
Model: DW-CN-0050

DISPLAY WARM MERCHANDISE

Increase impulse **Sale**



WARRANTY
PARTS AND LABOR



Authorized Dealer

COUNTERTOP MERCHANDISER

35L & 50L CAPACITY DISPLAY WARMERS



Features:

- Adjustable temperature controller
- Non-adjustable chrome plated shelf
- Stainless steel construction
- Temperature range: 30-90°C / 86-194°F



Model DW-CN-0035

- Single shelf unit
- Constructed with 1 front, 1 back hinged door
- Comes with 1 non-adjustable chrome plated shelf

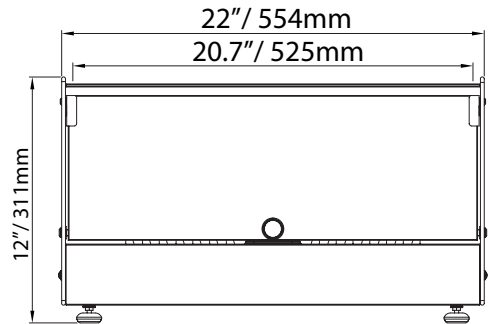
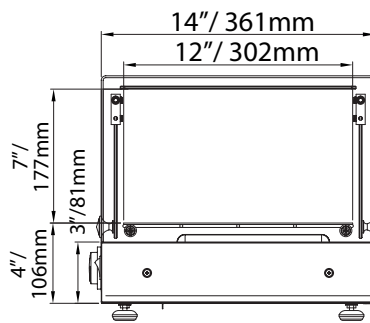

Model DW-CN-0050

- Dual shelf unit
- Constructed with 2 front, 2 back hinged doors
- Comes with 2 non-adjustable chrome plated shelves

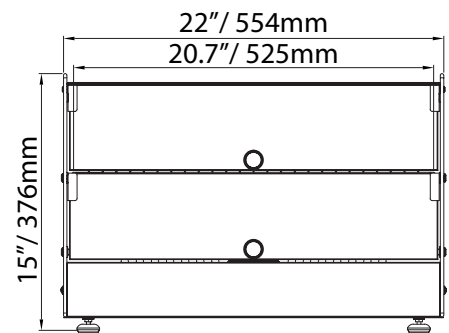
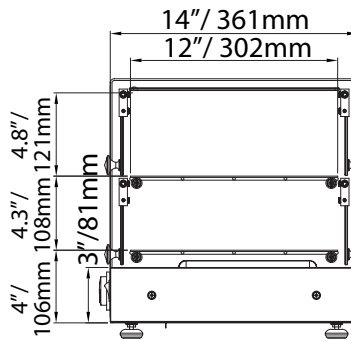

TECHNICAL SPECIFICATION

ITEM NUMBER	41869	41871
MODEL	DW-CN-0035	DW-CN-0050
STORAGE VOLUME	35L	50L
TEMPERATURE RANGE	30 - 90°C/ 86-194°F	30 - 90°C/ 86-194°F
POWER	800W	800W
RATED CURRENT	6.8 A	6.8 A
ELECTRICAL	110V / 60Hz	110V / 60Hz
NET DIMENSIONS (DWH)	22" x 14" x 12" / 554 x 361 x 311 mm	22" x 14" x 15" / 554 x 361 x 376 mm
NET WEIGHT	25lbs. / 11.4 kg	29.5 lbs./ 13.4 kg
GROSS DIMENSIONS	25" x 17.4" x 14" / 636 x 442 x 362 mm	25" x 17.4" x 16.8" / 636 x 442 x 427 mm
GROSS WEIGHT	42 lbs. / 19 kg.	47 lbs. / 21.3 kg.

OMCAN INC.

Telephone: 1-800-465-0234
 Fax: (905) 607-0234
 Email: sales@omcan.com
 Website: www.omcan.com



Follow us to keep up to date with the latest news and offers

