



COOKING EQUIPMENT

ENTRY MAX SERIES PIZZA OVENS WITH SINGLE CHAMBER AND DOUBLE CHAMBER

Item #: 40635/ 40636

Model #: PE-IT-0019-S/ PE- IT-0038-D

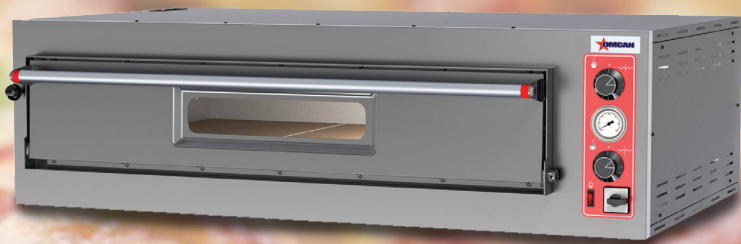

The Entry Max pizza ovens are practical which are ideal for pizzas, bread and kitchen products.



Authorized Dealer

COOKING EQUIPMENT

ENTRY MAX SERIES PIZZA OVEN WITH SINGLE CHAMBER



Features:

- Stainless steel front, two mechanical thermostats per chamber, heat resistant, light, main switch for each chamber, stainless steel door with glass and handle (Each chamber is independent)
- Up to 2 single-chamber oven can be placed on top of each other without the need for an exhaustor connection
- Insulation is evaporated fiberglass
- Left-sided handles
- Upon request the machines can be produced in a "full refractory stone" version and for single-phase operation.
- * *Special Order are available for the following upon request: stands, casters, hoods, vents and suction motor*



40635

5.56 kW Entry Max Series Pizza Oven with Single Chamber

ITEM NUMBER	40635
MODEL	PE-IT-0019-S
MAXIMUM TEMPERATURE	842° F / 450° C
ELECTRICAL	220V / 60 /3
POWER	5.56 kW
CHAMBER DIMENSIONS (LxDxH) * FULL REFRACTORY STONE	27.6" x 27.6" x 5.9" *26.4" 27" X 5.31"
EXTERNAL DIMENSIONS (LxDxH)	39" x 36" x 15"
PACKAGING DIMENSIONS (LxDxH)	40.2" x 39" x 20.9"
NET WEIGHT	74 kg./ 163 lbs. * 96 kg/ 211 lbs.
GROSS WEIGHT	88 kg./ 194 lbs. * 110 kg/ 242 lbs.

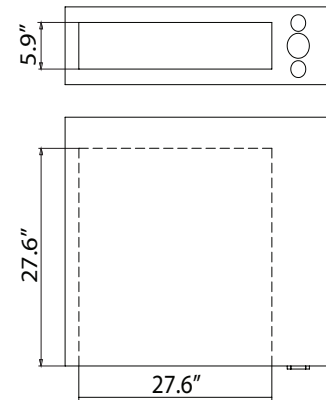
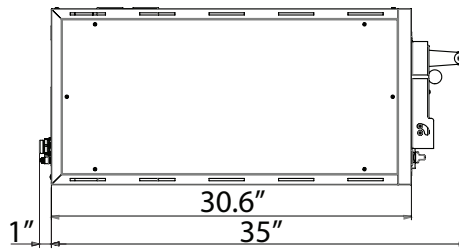
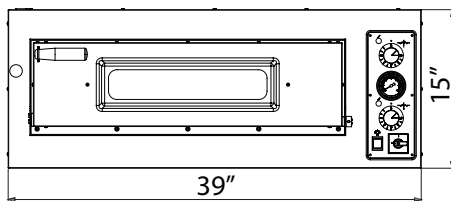

max 4 x 12"	max 4 x 13"	max 4 x 18"	max 1 x (24" x 16")

OMCAN INC.

Telephone: 1-800-465-0234
 Fax: (905) 607-0234
 E-mail: sales@omcan.com
 Website: www.omcan.com



Follow us to keep up to date with the latest news and offers





COOKING EQUIPMENT

ENTRY MAX SERIES PIZZA OVEN WITH DOUBLE CHAMBER

Features:

- Stainless steel front, two mechanical thermostats per chamber, heat resistant, light, main switch for each chamber, stainless steel door with glass and handle (Each chamber is independent)
- Up to 2 single-chamber oven can be placed on top of each other without the need for an exhaustor connection
- Insulation is evaporated fiberglass
- Left-sided handles
- Upon request the machines can be produced in a "full refractory stone" version and for single-phase operation.
- * *Special Order are available for the following upon request: stands, casters, hoods, vents and suction motor*



40636

11.2 kW Entry Max Series Pizza Oven with Double Chamber

ITEM NUMBER	40636
MODEL	PE-IT-0038-D
MAXIMUM TEMPERATURE	842° F / 450° C
ELECTRICAL	220V / 60 / 3
POWER	11.2 kW
CHAMBER DIMENSIONS (LxDxH) * FULL REFRACTORY STONE	(27.6" x 27.6" x 5.9") x 2 *26.4" 27" X 5.31"
EXTERNAL DIMENSIONS (LxDxH)	39" x 36" x 26.7"
PACKAGING DIMENSIONS (LxDxH)	40.2" x 39" x 32.3"
WEIGHT	149 kg./ 328.5 lbs. *193 kg./ 425 lbs,
GROSS WEIGHT	165 kg./ 363 lbs. *209 kg./ 460 lbs.

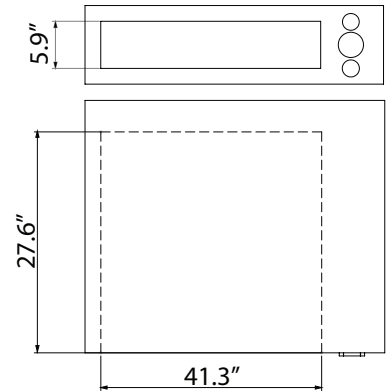
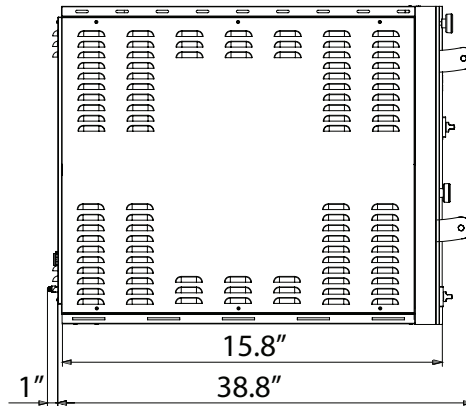
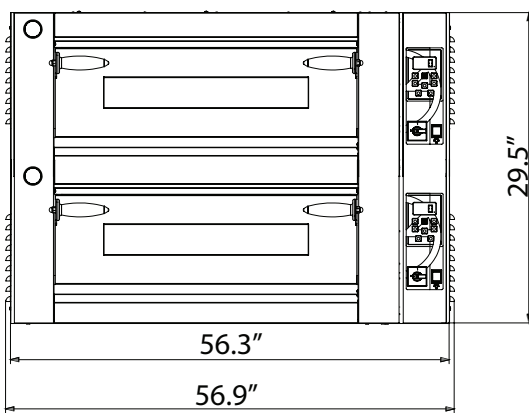

max 4 x 12"	max 4 x 13"	max 4 x 18"	max 1 x (24" x 16")

OMCAN INC.

Telephone: 1-800-465-0234
 Fax: (905) 607-0234
 E-mail: sales@omcan.com
 Website: www.omcan.com



Follow us to keep up to date with the latest news and offers

