



# BROILER

CENTER OF ALL YOUR FOOD SERVICE NEEDS

## QUARTZ ADJUSTABLE DOUBLE SALAMANDER

Item #: 39582

Model: CE-CN-1633-S

*High Performance  
and Quality  
Double Salamander*

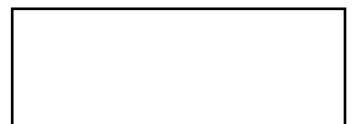

Authorized Dealer



# BROILER

## ADJUSTABLE DOUBLE SALAMANDER



### Detail Shots

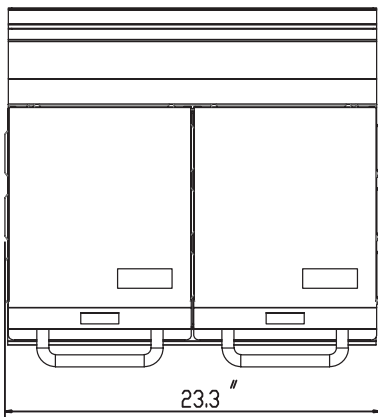

TOP VIEW

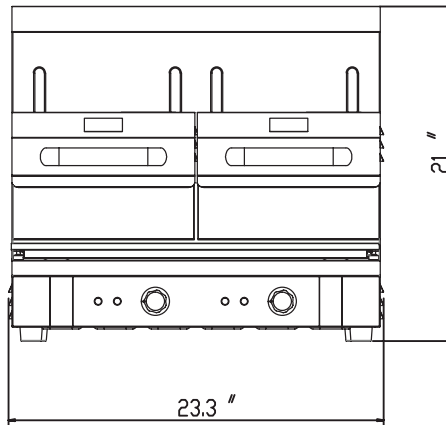

FRONT VIEW

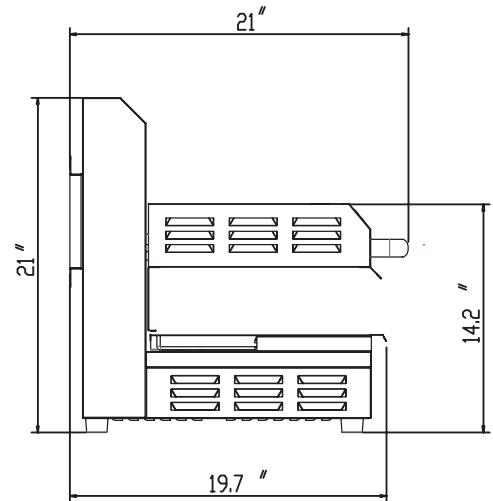

SIDE VIEW

### Features:

- Quick quartz heating from top.
- Adjustable top grill for quick cooking with minimal heat loss.
- Energy server device.
- Removable base tray.
- Rubber feet.
- Wall mounted available.
- Adjustable heating supply.
- Built with stainless steel.

Ideal for heating, baking, cooking pizzas, sandwiches, cakes and much more. It distributes heat evenly for great cooking results.

### PRODUCT SPECIFICATIONS

|              |                             |                      |                          |
|--------------|-----------------------------|----------------------|--------------------------|
| ITEM         | 39582                       | WEIGHT               | 25 lbs. / 11.3 kg.       |
| MODEL        | CE-CN-1633-S                | PACKAGING WEIGHT     | 29 lbs. / 13.2 kg.       |
| MATERIAL     | Stainless Steel             | DIMENSIONS (DWH)     | 21" x 23.3" x 21"        |
| WARMING BASE | 22.8" x 14" / 58cm x 35.5cm | PACKAGING DIMENSIONS | 53.3cm x 59.2cm x 53.3cm |
| POWER        | 3200 W                      |                      | 24.8" x 24.24" x 22.4"   |
| ELECTRICAL   | 240V / 60 Hz                |                      | 63cm x 61.6cm x 56.9cm   |

## OMCAN INC.

Telephone: 1-800-465-0234  
 Fax: (905) 607-0234  
 E-mail: sales@omcan.com  
 Website: www.omcan.com



Follow us to keep up to date with the latest news and offers

