



REFRIGERATION

CENTER OF ALL YOUR FOOD SERVICE NEEDS

COUNTERTOP DISPLAY WITH 78L CAPACITY

Item #: 39551

Model: RS-CN-0078



*High Performance
and Quality
Countertop Display*

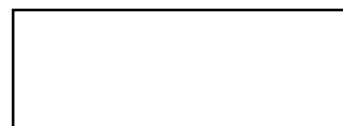

Authorized Dealer



REFRIGERATION

COUNTERTOP DISPLAY WITH 78L CAPACITY



Features:

- Eye catching internal LED lighting
- Stainless steel exterior and interior
- Digital temperature controller and display
- Adjustable PVC coated shelves
- Maintenance free controller

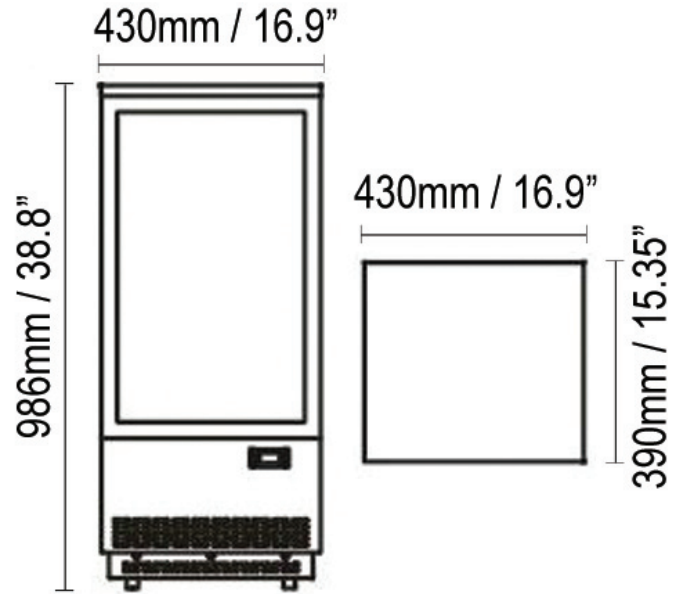

PRODUCT SPECIFICATIONS

ITEM NUMBER	39551
MODEL	RS-CN-0078
CAPACITY (L/ CU. FT.)	78L /2.75 Cu. Ft.
TOTAL POWER INPUT	180 W
ELECTRICAL	110 v / 60 Hz
STORAGE TEMPERATURE	0-12°C
DIMENSIONS (WDH)	16.9" x 15.35" x 38.8"
PACKAGING DIMENSIONS	19" x 18" x 41"/ 482.6 x 457 x 1041 mm
NET WEIGHT	33.8 kg/ 74.5 lbs.
PACKAGING WEIGHT	36 kg/ 80 lbs.

OMCAN INC.

Telephone: 1-800-465-0234
 Fax: (905) 607-0234
 E-mail: sales@omcan.com
 Website: www.omcan.com



Follow us to keep up to date with the latest news and offers

