

CREPE GRIDDLE



This counter top crepe griddle is an easy and efficient way to make delicious crepes. It features a cast iron plate, stainless steel body, temperature dial and indicator lights.

SPECIFICATIONS

Item #	23571
Electrical	120V / 60Hz
Temperature Range	60°C – 300°C / 140°F – 570°F
Plate Diameter	15.62"
Weight	48.5 lbs.
Packaging Weight	53 lbs.
Dimensions (DWH)	17.5" x 20" x 9"
Packaging Dimensions	21.5" x 22" x 13.75"

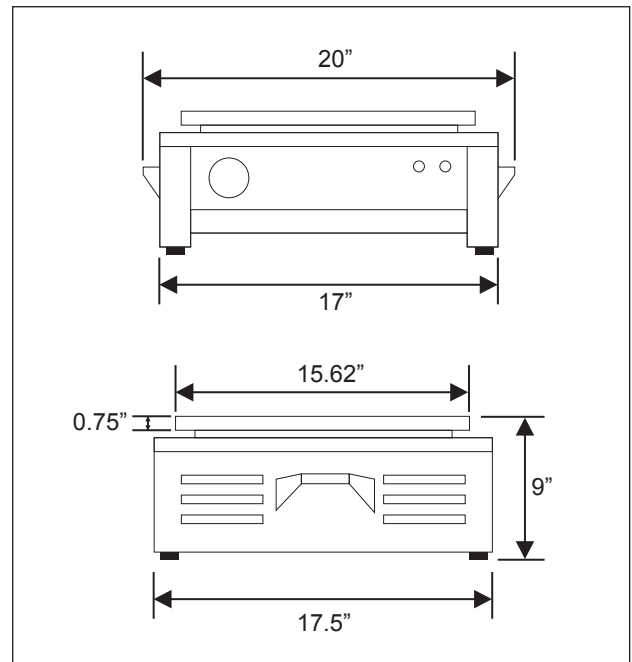

Mississauga, Ontario, Canada

Niagara Falls, New York, USA

Tel: (905) 828-0234 Toll-Free: 1-800-465-0234 Fax: (905) 607-0234 Email: sales@omcan.com

www.omcan.com