

SERVER

• E S S E N T I A L S •

IntelliServ® Warmer 1/3-Size Food Pan

SPECIFICATION SHEET

FAST FACTS

The end-operated, IntelliServ® water-bath warmer is ideal for effective kitchen placement while digital temperature control ensures accurate heating and holding – to the last serving.

APPLICATIONS

- Great for difficult to hold products such as chocolate, alfredo and hollandaise sauce that require precise temperature control
- Open design adapts to menu changes for topping, finishing or plating with ladles, pumps or squeeze bottles

DETAILS

- Warm up to 6-quarts in 8-in of countertop space
- Digital temperature control ensures accurate holding of delicate soups and sauces; display provides instant feedback of heat setting and status
- Modular design holds (1) 1/3 -, (2) 1/6 - or (3) 1/9 -size food pans up to 6-in deep
- NSF listed rethermalizer - quickly heats to a safe serving temperature before bacteria has an opportunity to grow
- Cool-touch rim protects staff from typical hot-zone risks when switching pans out



Shown: 1/6-pans and ladles



Shown: 1/6-pan, lid, ladle and bottle holder



IS-1/3 86090



Shown: 1/6-pans and FP-1/6 pumps



Smart food warmers
serve fresh all day long.
Adapt for topping, finishing or
plating with ladles, pumps
or high-temp squeeze bottles.

Everything you need and more, in less.

INTELLISERV® WARMER MODEL: IS-1/3

Server IntelliServ® model IS-1/3 is an end-operated, countertop warmer. This water-bath, food-pan warmer with digital temperature control (F°/C°) is constructed of stainless steel with a thermoset plastic water vessel and cast aluminum heat plate. This NSF-listed rethermalizer holds up to 6-quarts in (1) 1/3-size, (2) 1/6-size, or (3) 1/9-size food pans, 6-in deep and can be configured to serve with ladles, pumps or high-temp squeeze bottles (sold separately). NEMA 5-15P plug with 72-in power cord. 2-Year warranty.

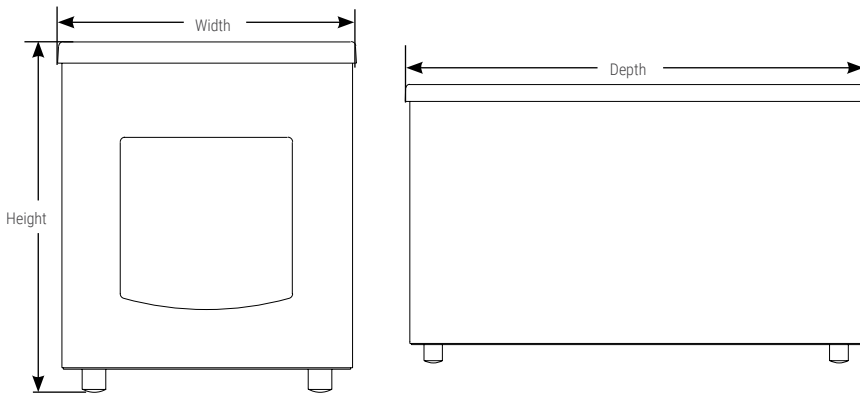

FOOD PAN WARMER

order amt	model/item	description	capacity	dims (H x W x D)	plug	electrical	watts	weight
<input type="checkbox"/>	IS-1/3 86090	1/3-size food pan warmer, countertop	up to 6-qt; using 1/3-size, 6" deep food pan	9 5/16" x 7 15/16" x 15 3/8"		120 V AC 4.2 A	500	17 lb

ACCESSORY ITEMS

order amt	item	description	order amt	item	description
<input type="checkbox"/>	86312	FP-1/6 pump, 1-oz (fits 6" deep pan)	<input type="checkbox"/>	90089	1/6-size, 6" deep, 2 3/4-qt pan
<input type="checkbox"/>	87530	1/6-size squeeze bottle holder w/(3) 16-oz bottles	<input type="checkbox"/>	90094	1/6-size pan lift-off lid
<input type="checkbox"/>	87213	stainless steel ladle, 6", 1-oz	<input type="checkbox"/>	90106	1/9-size, 4" deep, 1 1/8-qt pan

SERVE FRESH ALL DAY LONG WITH INTELLISERV®.
SERVER-PRODUCTS.COM | 1.800.558.8722