



POTATO PEELER PI-30

Stainless steel construction commercial potato peeler. Able to process full 50 lb. case in 1 batch.



Capacity per load: 66 lbs
Timer (min-max): 0 ' - 6 '
Total loading: 1 Hp
Electrical supply: 120V / 60 Hz / 1~ (5.5 A)
Electrical connection: --

External dimensions (WxDxH)

- ✓ Width: 24.5 "
- ✓ Depth: 29.9 "
- ✓ Height: 39.5 "

External dimensions with stand

- ✓ Width with stand: 24.5 "
- ✓ Depth with stand: 29.9 "
- ✓ Height with stand: 49.4 "

Net weight: 132.5 lbs

AVAILABLE MODELS

1000638 Potato peeler PI-30 120/60/1

* Ask for special versions availability

SALES DESCRIPTION

Stainless steel construction commercial potato peeler. Also suitable to peel carrots and other similar products. 0-6 min. timer. Removable turntable for easy cleaning.

High capacity and production owing to lateral stirrers covered with silicon carbide abrasive (approved by NSF). Aluminium base plate lined with silicon carbide abrasive (approved by NSF). Construction in stainless steel.

- ✓ Auto-drag of waste to the drain.
- ✓ Energy efficiency thanks to engine optimisation.
- ✓ Liftable transparent polycarbonate cover, complete with locking and safety device.
- ✓ Aluminium door with hermetic seal and safety device.
- ✓ Waterproof control board (IP65): Improved reliability against moisture and water splash.
- ✓ Water inlet system with non-return air break.
- ✓ Auxiliary contact for external electric valve.
- ✓ 0-6min timer and possibility of continuous operation.

OPTIONAL

- Stainless steel floor stand complete with filter with no-foam feature.

ACCESSORIES

- Stands for potato peelers

SPECIFICATIONS

Hourly production: 1300 lbs / 1600 lbs



DYNAMIC PREPARATION
COMMERCIAL FOOD PEELER

product sheet
updated 03/30/23



POTATO PEELER PI-30

Stainless steel construction commercial potato peeler. Able to process full 50 lb. case in 1 batch.



DYNAMIC PREPARATION
COMMERCIAL FOOD PEELER

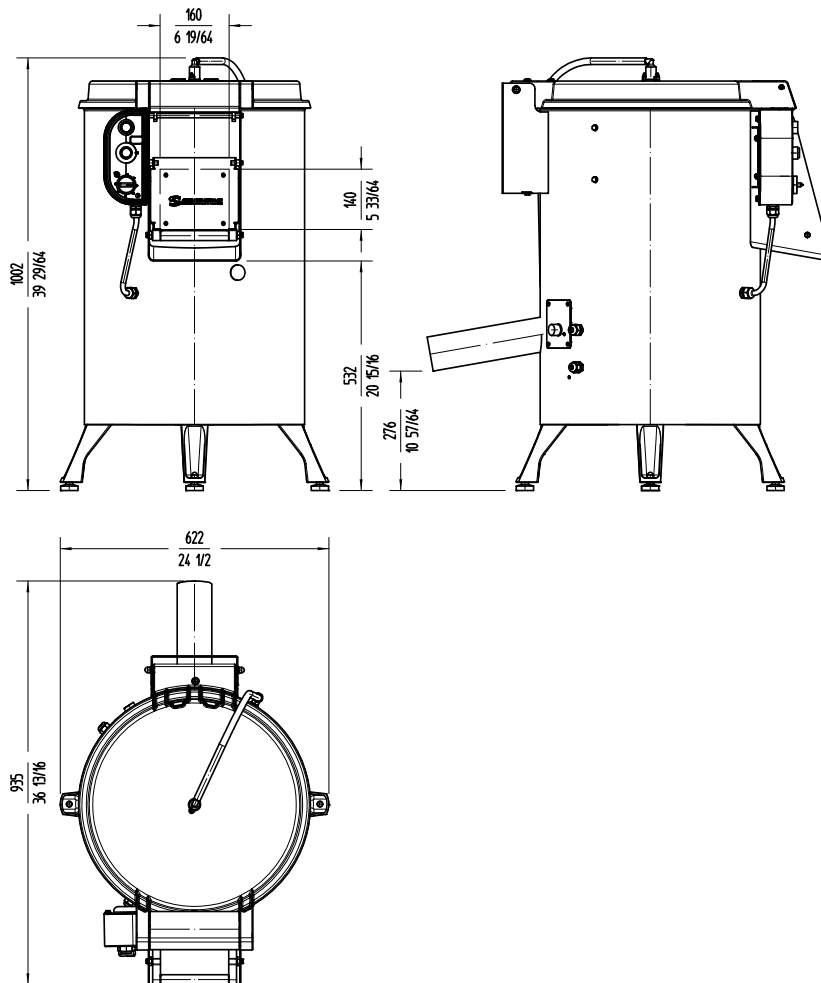

sammic | www.sammic.us
Food Service Equipment Manufacturer

usa@sammic.com
1225 Hartrey Avenue
60202-1056 Evanston, IL

phone +1 (224) 307-2232
toll free +1 844 275 3848



Project	Date
Item	Qty
Approved	

product sheet
updated 03/30/23