



WCM60PT

Café DECO®

Thermal Coffee Brewer



Café DECO® Thermal Coffee Brewer



Carafes not included.

MAIN FEATURES

- Brews over 3.9 gallons per hour (62, 8 oz.cups per hour)
- High-end industrial design
- Upper warming surface with guardrails
- Stainless steel construction
- Ready and Power lights
- Fits large, 64 oz. thermal carafes
- Built-in, pour-over and automatic refill features
- Push-button brew start
- Separate hot water faucet for tea, soup and other hot drinks
- Two-Year Parts and One-Year Labor Warranty

ELECTRICAL

Voltage: 120

Frequency: 60Hz

Watts: 1,660

Amps: 13.8

Plug Type: NEMA 5-15P ⓘ

Cord Length: 6 feet



SALES FEATURES

Satisfy high demand for fresh-brewed coffee with this high-performance commercial kitchen essential. Designed with a built-in, quick-fill pour-over feature and an easy-draw hot water faucet for soup and drinks, this plumbed unit offers the speed and efficiency today's busy foodservice operations need. A touch of a button brews coffee to perfection in minutes. Ideal for use with thermal carafes to keep coffee hot and ready to serve for extended periods of time.



@waringcommercial

©2021 Waring Commercial
314 Ella T. Grasso Avenue, Torrington, CT 06790
Tel. 800-492-7464 • Fax 860-496-9008

waringcommercialproducts.com

WCM60PT



OPTIONAL ACCESSORIES



WTC64 64-oz. Stainless Steel Thermal Carafe

DIMENSIONS

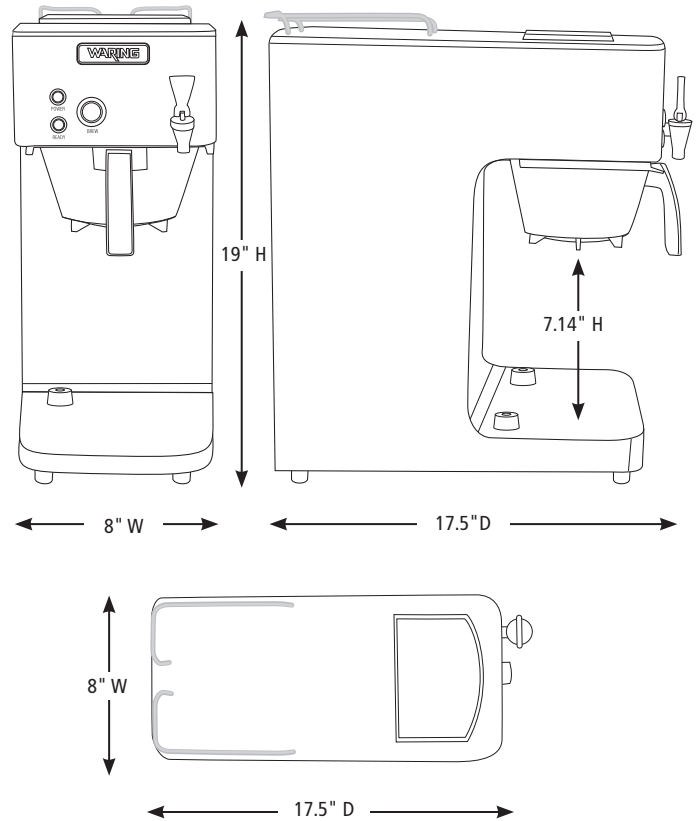

Out of Box Weight: 18 lb.

ORDERING INFORMATION	#STD. PKG.	GIFTBOX WEIGHT	CUBIC FEET	BOX DIMENSIONS D X W X H	UPC	CASE PKG.	MC WEIGHT	MC DIMENSIONS D X W X H	MBC
WCM60PT – Thermal Coffee Brewer	1	22	3.06	22.875" x 10.25" x 21"	040072089787	1	25.19	23.5" x 11" x 22"	10040072089184

