



WCM50

Café DECO®

Pour-Over Coffee Brewer



Café DECO® Pour-Over Coffee Brewer



Decanters not included.

MAIN FEATURES

- Brews over 3 gallons per hour (52, 8 oz.cups per hour)
- High-end industrial design
- Two separately controlled upper and lower warmers keep coffee at the ideal serving temperature
- Self regulating warmers prevent overheating – Saves energy compared to continuous heat models
- Upper warmer with guardrails
- Stainless steel construction
- Ready and Power lights
- Fits large, 64 oz. glass decanters
- No plumbing required! Completely portable, 64 oz. coffeemaker!
- Two-Year Parts and One-Year Labor Warranty

ELECTRICAL

Voltage: 120

Frequency: 60Hz

Watts: 1,800

Amps: 15

Plug Type: NEMA 5-15P ⓘ

Cord Length: 6 feet



SALES FEATURES

Introducing the new Café Deco® Series coffeemaker designed to meet high demand for fresh-brewed coffee at today's busy foodservice operations. The pour-over design provides the ease and convenience of portability – no plumbing needed. Cold water is poured through the top, and coffee brews to perfection in minutes. Switch on one or both of the warmers to maintain the ideal serving temperature. Stainless steel construction ensures durability and wipes clean in seconds.



@waringcommercial

©2021 Waring Commercial
 314 Ella T. Grasso Avenue, Torrington, CT 06790
 Tel. 800-492-7464 • Fax 860-496-9008

waringcommercialproducts.com

WCM50



OPTIONAL ACCESSORIES



WCDB64 64-oz. Glass Decanter

DIMENSIONS

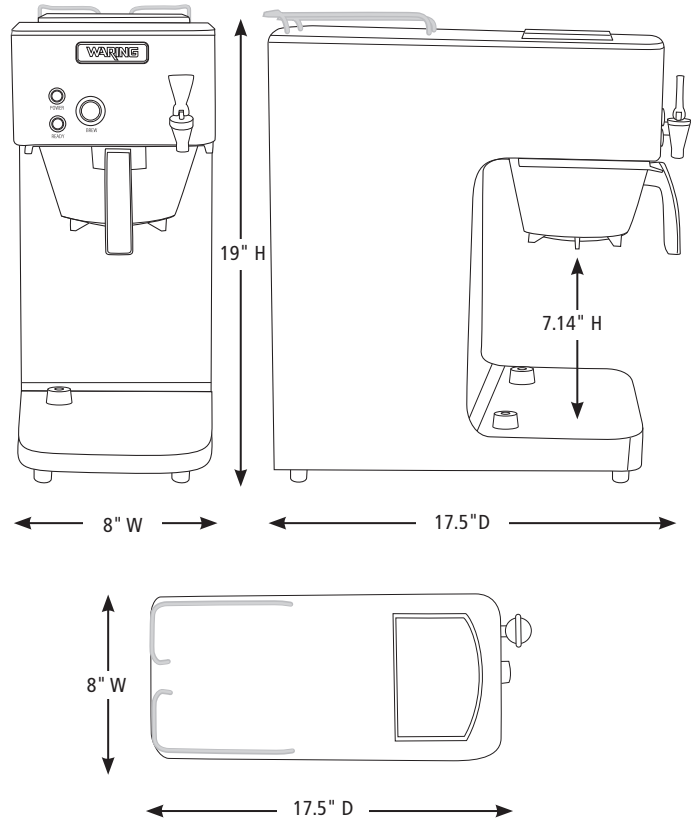

Out of Box Weight: 20 lb.

ORDERING INFORMATION	#STD. PKG.	GIFTBOX WEIGHT	CUBIC FEET	BOX DIMENSIONS D X W X H	UPC	CASE PKG.	MC WEIGHT	MC DIMENSIONS D X W X H	MBC
WCM50 – Pour-Over Coffee Brewer	1	22	2.83	22.875" x 10.25" x 20.75"	040072089190	1	22.11	23.5" x 11" x 22"	10040072089197



@waringcommercial

©2021 Waring Commercial
314 Ella T. Grasso Avenue, Torrington, CT 06790
Tel. 800-492-7464 • Fax 860-496-9008

waringcommercialproducts.com

21WC079922 / REV 09/21