



60" SX SERIES VALUE RANGE

6 Open Burners & 24" Manual Griddle



Model SX60F-6B24G



Intertek

SPECIFIER STATEMENT

60" wide gas restaurant range, Vulcan Model No. SX60F-6B24G. Stainless steel front, sides, backriser, high shelf and bullnose. High temperature burner knobs with set screw. Stainless steel bullet feet. Porcelain door liner and oven bottom. Six 28,000 BTU/hr. cast top burners with lift-off burner heads. One shrouded flash tube pilot for every two burners. 12" x 12" cast top grates with aeration bowls. Heavy duty top grates and burner heads. 3/4" thick x 24" w manual griddle, 30,000 BTU/hr. Compression spring door hinge system for durability. Two 30,000 BTU/hr. standard ovens each measure 26 3/4" w x 26" d x 13 3/4" h. Thermostat adjusts from 250° to 500°F. One oven rack with four rack positions for each oven. 3/4" rear gas connection and gas pressure regulator. Total input: 258,000 BTH/hr.

Exterior Dimensions:

63" w x 32" d x 58" h on 6" adjustable legs

Project _____

AIA # _____ SIS # _____

Item # _____ Quantity _____ C.S.I. Section 114000

MODELS

SX60F-6B24GN

2 Standard Ovens / 24" Manual Griddle / Natural Gas

SX60F-6B24GP

2 Standard Ovens / 24" Manual Griddle / Propane

STANDARD FEATURES

- Stainless steel front, backriser, lift-off high shelf
- 6" stainless steel adjustable legs
- 28,000 BTU/hr open top burners with lift-off heads
- Shrouded flash tube pilot system (one pilot per two burners)
- 12" x 12" cast top grates with aeration bowls
- Welded crumb tray
- 30,000 BTU/hr. standard oven cavity measures 26 3/4" w x 26" d x 13 3/4" h
- Oven thermostat adjusts from 250° to 500°F
- One oven rack and four rack positions for each oven
- 3/4" thick x 24" w manual griddle, 30,000 BTU/hr. total
- 3/4" rear gas connection and gas pressure regulator
- One year limited parts and labor warranty

ACCESSORIES (PACKAGED & SOLD SEPARATELY)

- Extra oven rack
- Reinforced backriser and high shelf for mounting salamander broiler
- Set of six casters (two locking)

60" SX SERIES VALUE RANGE – 6 Open Burners & 24" Manual Griddle

Approved by _____ Date _____ Approved by _____ Date _____

INSTALLATION INSTRUCTIONS

1. A pressure regulator sized for this unit is included. Natural gas 5.0" W.C., propane gas 10.0" W.C.
2. Gas line connecting to range must be 3/4" or larger. If flexible connectors are used, the inside diameter must be 3/4" or larger.
3. An adequate ventilation system is required for commercial cooking equipment. Information may be obtained by visiting the National Fire Protection Association website at <https://www.nfpa.org/>. Refer to NFPA No. 96.
4. These units are manufactured for installation in accordance with ANSZ223.1A (latest edition), National Fuel Gas Code. Copies may be obtained from The American Gas Association, 400 N Capitol St. NW, Washington, DC 20001, www.AGA.org.

5. Clearances

	Rear	Sides
A. Combustible	12"	10"
B. Standard Oven Non-combustible	6"	0"
C. Convection Oven Non-combustible	Min. 4"	0"
6. For proper combustion, install equipment on adjustable legs or casters provided with unit.

NOTE: In line with its policy to continually improve its product, Vulcan reserves the right to change materials and specifications without notice.

**SPECIFY TYPE OF GAS WHEN ORDERING.
SPECIFY ALTITUDE WHEN ABOVE 2,000 FEET.**

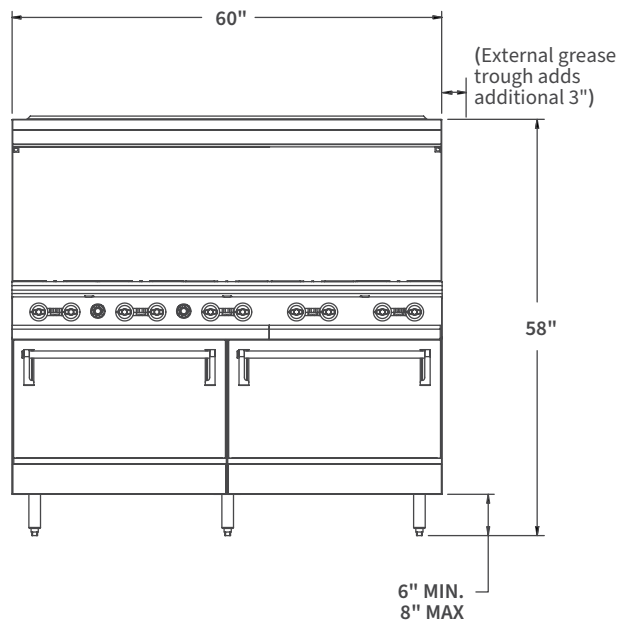
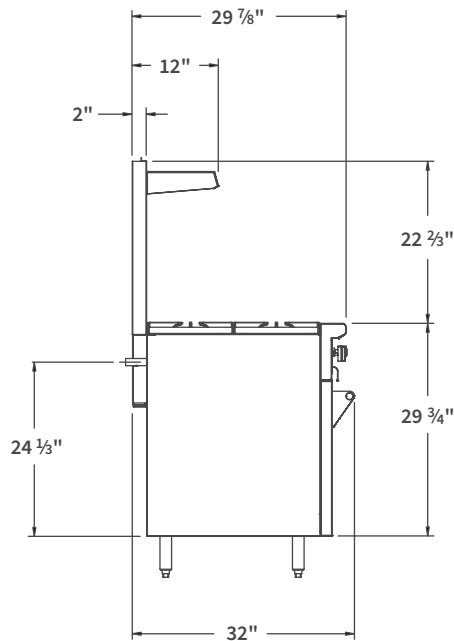

Top Configuration	Model	Description	Total Input BTU / Hr.	Shipping Weight Lbs. / KG
	SX60F-6B24GN	6 Burners / 2 Standard Ovens / 24" Manual Griddle / Natural Gas	258,000	815 / 370
	SX60F-6B24GP	6 Burners / 2 Standard Ovens / 24" Manual Griddle / Propane	258,000	815 / 370

This appliance is manufactured for commercial use only and is not intended for home use.

As continued product improvement is a policy of Vulcan, specifications are subject to change without notice.