

Champion®

The Dishwashing Machine Specialists

Project _____
Item No. _____
Quantity _____

PRO SERIES 2-TANK RACK CONVEYOR

STANDARD FEATURES

- **NEW Auto Delime Function**
- Perpetual rack advance system, with intuitive jam alert, and drive protection
- Proportional rinse, delivering unmatched total ware coverage, utilizing digital pattern cloning, stainless steel nozzles
- 348 racks per hour
- 100 GPH with energy sentinel (idle pump shut-off)
- Prodigy series HMI display, intuitive condition alerts, with user friendly cleaning and operation visual guidance, multi-lingual, touch control
- Proactive maintenance interface, self-diagnostics, problem recognition, with repair recommendation, from HMI touch screen
- Programmable machine dwell with automatic rack alignment into the optimal wash zone
- **Automatic drain valve *Exclusive!***
- Single-piece hood design
- Single-piece stainless steel upper and lower wash arm manifolds
- Two-point electrical connection, machine and built-in booster heater
- 20" standard vertical clearance which accommodates 18" x 26" sheet pans
- Full 180° opening leak proof insulated hinged access doors
- Stainless steel heavy gauge construction including base, legs and feet
- Enclosure panels (front and sides)
- 2 HP pump motors, with stainless steel impeller
- Factory Authorized Start-up
- Vent fan control
- **ENERGY STAR® Qualified**
- **Made in America**



PRO SERIES

64 PRO Electric

High Temperature 2-Tank Rack Conveyor
Dishwashing Machine



Model 64PRO shown with optional vent cowl and heat-recovery



Photo is for general visual representation only. Please refer to specifications for the latest detailed product information.

SPECIFIER STATEMENT

Specified unit will be Champion Model 64 PRO Series 2-tank high temperature rack conveyor dishwashing machine. Features top mounted Prodigy HMI user interface controls with proactive maintenance software, proportional rinse, using only 100 GPH, progressive anti-jam drive system, energy sentinel (idle pump shut-off), 348 racks per hour, single-piece hood design, single-piece stainless steel upper & lower wash arms manifolds, full 180° opening leak proof insulated hinged access doors.

1 year parts and labor warranty.

Champion Industries, Inc.
3765 Champion Blvd., Winston-Salem, NC 27105
Tel: 336/661-1556 Fax: 336/661-1979
www.championindustries.com

PRO SERIES

64 PRO Electric

High Temperature 2-Tank Rack Conveyor
Dishwashing Machine

Champion®

The Dishwashing Machine Specialists

MODEL 64 PRO Shipping weight crated: 865lbs

Dimensions shown in inches [mm]

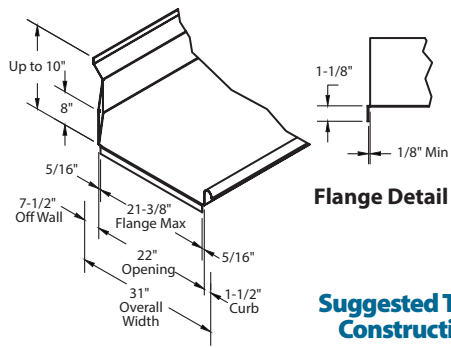
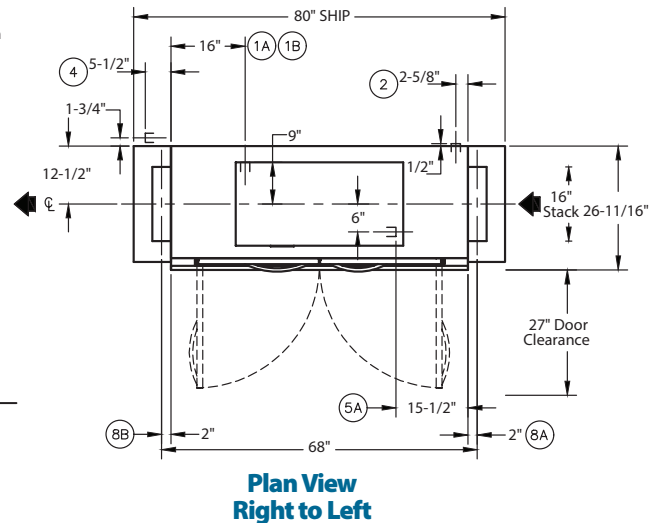
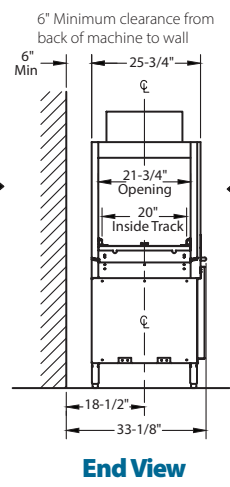
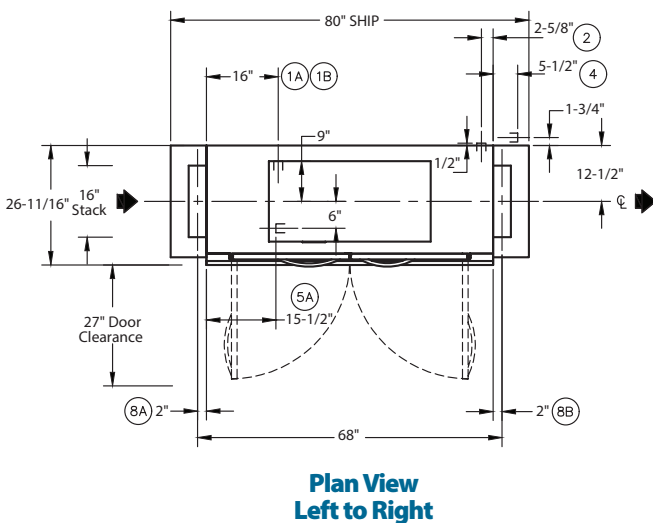
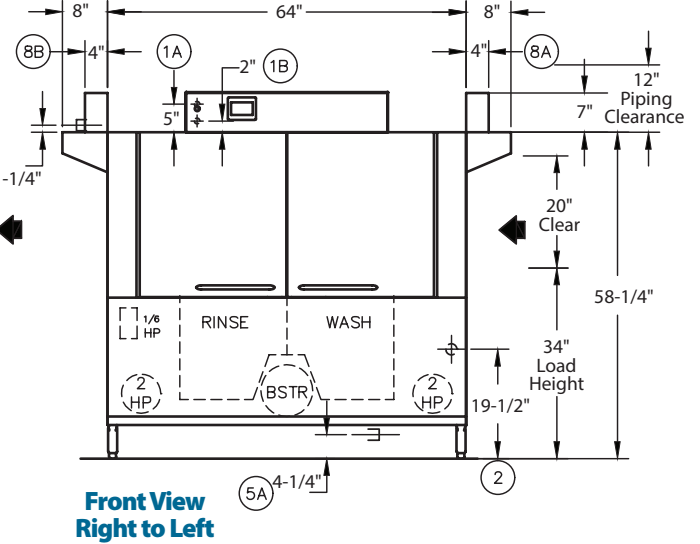
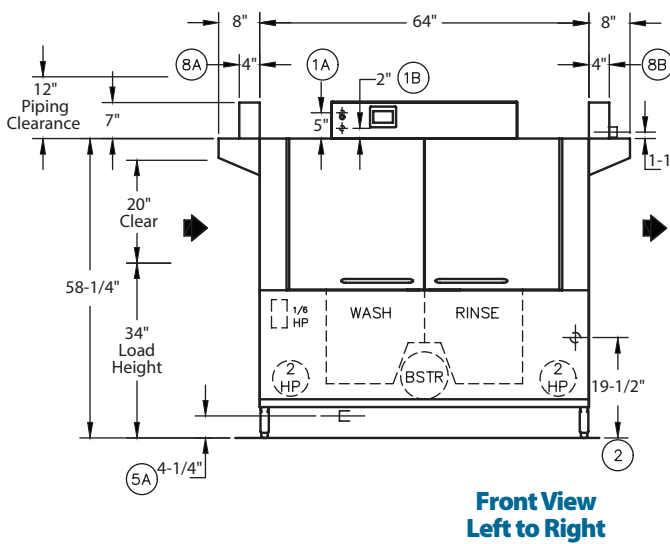

PRO SERIES

64 PRO Electric

High Temperature 2-Tank Rack Conveyor
Dishwashing Machine

Champion®

The Dishwashing Machine Specialists

Utilities	
1	Electrical Connection A Machine electrical connection and booster electrical connection
2	Hot Water Machine with built-in booster Main connection 3/4" NPT
3	Cold Water Connection 1/2" NPT
4	Hot Water Machine with no booster Main water connection 3/4" NPT
5	Drain Connection 1 1/4" NPT
8	Vents A Stack connection - Load end 200 CFM @ 1/4" static pressure B Stack connection - Unload end 400 CFM @ 1/4" static pressure

Warning: Plumbing and electrical connections should be made by qualified personnel who will observe all the applicable plumbing, sanitary, safety codes and the National Electrical Code.

Note: Water Hammer Arrestor (meeting ASSE-1010 standard or equivalent) to be supplied (by others) in common water supply line at service connection.

Plumbing Notes: Because of the variation in house-supplied steam and water pressures, steam and water pressure regulating valves (PRVs) may be needed. (Water PRV is standard on machines with booster.) The PRVs can either be purchased from Champion or obtained locally.

Venting Notes: Fabricated duct size: 3-7/8" x 15-7/8" (Outside dimensions)

Optional Drain Tempering: 1/2" NPT cold water connection required. 1/2" NPT drain connection from back flow preventer to house drain. (FIELD INSTALLED and PLUMBED).

Two Tank PRO Rack Machine and Booster Ratings

The tables below give the ratings for each model. The ratings include the requirements of the 12 and 21 kW booster heaters when they are use.

Machines with a dual point electrical connection:

64 PRO Electric, 21 kW Booster Only			
Electrical Specifications	Rated Amps	Minimum Supply Circuit Ampacity	Maximum Overcurrent Protective Device
208/60/3	59	80	80
240/60/3	51	70	70
480/60/3	26	35	35
575/60/3	22	30	30

64 PRO Electric, 12 kW Booster Only			
Electrical Specifications	Rated Amps	Minimum Supply Circuit Ampacity	Maximum Overcurrent Protective Device
208/60/3	34	45	45
240/60/3	29	40	40
480/60/3	15	20	20
575/60/3	12	15	15

64 PRO Electric Tank Heat, Machine & Tank Heat Only			
Electrical Specifications	Rated Amps	Minimum Supply Circuit Ampacity	Maximum Overcurrent Protective Device
208/60/3	90	110	110
240/60/3	80	100	100
480/60/3	40	50	50
575/60/3	31	40	40

SPECIFICATIONS

Capacity

Racks per hr. (NSF rated)	348
Wash tank (US gal.)	17
Power Rinse tank	17
Conveyor speed (ft/min.)	9.55
Conveyor speed Pot/Pan Mode (ft/min.)	4.6
(only one rack at a time in Pot/Pan Mode)	

Motor Horsepower

Drive	1/6
Wash	2
Rinse	2

Water Consumption

US Gal. per hr. (max. use)	100
US Gal. per rack	0.28

Heating

Wash Tank Heat, electric (kW)	15
Power rinse, electric (kW)	10
Electric booster (built-in) (kW supplied for 40°F rise)	12
Electric booster (built-in) (kW supplied for 70°F rise)	21
<i>Booster heaters completely inter plumbed, controls are intertwined</i>	

Venting

Load end (minimum CFM)	200
Unload end (minimum CFM)	400

Standard 20" x 20" rack complement

Peg	1
Flat	1

Machines with a single point electrical connection:

64 PRO Electric Tank Heat, 21 kW 70° Booster			
Electrical Specifications	Rated Amps	Minimum Supply Circuit Ampacity	Maximum Overcurrent Protective Device
208/60/3	n/a	n/a	n/a
240/60/3	131	175	175
480/60/3	66	90	90
575/60/3	53	70	70

64 PRO Electric Tank Heat, 12 kW 40° Booster			
Electrical Specifications	Rated Amps	Minimum Supply Circuit Ampacity	Maximum Overcurrent Protective Device
208/60/3	124	175	175
240/60/3	109	150	150
480/60/3	55	70	70
575/60/3	43	60	60

Note: Machine ships as a two point electrical connection standard. Single point available at the factory upon request.

Due to an ongoing value analysis program at Champion, specifications contained in this catalog are subject to change without notice.

Champion Industries, Inc., 3765 Champion Blvd., Winston-Salem, NC 27105 • 336/661-1556 • Fax: 336/661-1979 • www.championindustries.com

PRO SERIES

PRO SERIES RACK CONVEYOR

64 PRO Electric

High Temperature 2-Tank Rack Conveyor Dishwashing Machine

OPTIONS & ACCESSORIES

- Tank heat: choice of steam coil or electric
- Single-point electrical connection, same for machine and booster (except 208/3) (Field convertible)
- 33" Blower Dryer – steam or electric
- Booster Heater Steam: 40°F or 70°F rise (*see spec sheet*)
- Booster Heater Electric: 40-70°F rise (built-in only)
- Cantilever sideloader (with hood) for 90° load operation
- 24" Sideload
- 30" Sideload (accepts sheet pans)
- Racks (specify type)
 - Flat
 - Peg
 - Sheet Pan
 - Hotel Pan
- Table limit switch, unmounted (Whisker or Button style) (recommended on all rack conveyor installations) (unmounted)
- Vent cowl, stainless steel with 7" stack and locking damper
- Extended vent cowl
- Water pressure regulating valve (unmounted) (standard with booster)
- Water hammer kit (unmounted)
- Drain tempering kit (unmounted)
- Model PRO 90 Unloader (90° corner conveyor table)
- Model RCT 64 or RCT 84 roller conveyor table (See factory for custom length)
- Splash shields
- ION scale prevention device (unmounted)
- Stainless steel rear enclosure panels
- Detergent and rinse-aid pump kit (factory mounted)
- Heat Recovery

2	Hot Water 110°F 3/4" NPT initial fill; 30 psi minimum feed
3	Cold Water (min. 55°F) 1/2" NPT Water Consumption 100 GPH at 20 psi; 30 psi minimum feed
4	Vent (4"x16" inside) Unload end: 200CFM at 1/4" S.P. Direct venting not required if canopy venting is in use.

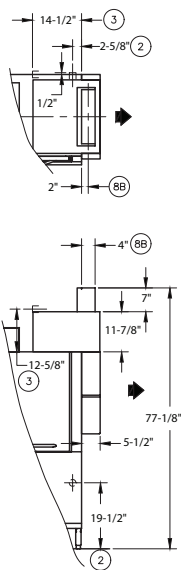

Champion®

The Dishwashing Machine Specialists



NEW PRO-90
90° Corner Conveyor Table (shown)
Unloader only



Cantilever Sideload
(No hood)



Model RCT 64 or RCT 84
Roller Conveyor Table

Champion Industries, Inc.,
3765 Champion Blvd., NC 27105
336/661-1556 • Fax: 336/661-1979
ChampionIndustries.com