



Project _____
 AIA # _____ SIS # _____
 Item # _____ Quantity _____ C.S.I. Section 114000



HL400 LEGACY+ 40-Quart Maximum Heavy-Duty Mixer



SPECIFIER STATEMENT

Specified mixer will be an NSF rated 40-quart maximum heavy-duty, all-purpose mixer with Hobart PLUS System, three fixed speeds plus a stir speed. Mixer has 1½ HP output at the planetary shaft and all-gear transmission. Features include automatic time recall, swing-out bowl, Shift-on-the-Fly™ controls and manual bowl lift. Mixer finished with a metallic gray hybrid powder coat and has a stainless steel bowl guard.

MODEL

- HL400** 40-Quart Maximum Heavy-Duty Mixer
- HL400C** 40-Quart Maximum Heavy-Duty Mixer with Maximum Security Correctional Package

STANDARD FEATURES

Features in bold are exclusive to Hobart

- + **PLUS System**
 - **VFDadvantage** variable frequency drive
 - **Maximum capacity** overheat protection
 - **Reinforced planetary shaft system**
- + **Triple interlock system with MagnaLock technology**
- + Heavy-duty 1½ HP motor
- + Gear transmission
- + Three fixed speeds, plus stir speed
- + **Shift-on-the-Fly™ controls**
- + Soft start agitation technology
- + **20-minute SmartTimer™**
- + Automatic time recall
- + Large, easy-to-reach controls
- + **Single point bowl installation**
- + **Ergonomic swing-out bowl**
- + #12 taper attachment hub
- + Open base
- + Metallic gray hybrid powder coat finish
- + Stainless steel removable bowl guard
- + Rubber foot pads provided

ACCESSORY PACKAGE

Featuring Hobart Quick Release™ Agitators

- HL400-1STD Standard Accessory Package includes:
 - + 40-quart stainless steel bowl
 - + 40-quart “B” beater
 - + 40-quart “D” wire whip
 - + 40-quart “ED” dough hook

HL400 LEGACY+ 40-QUART MAXIMUM HEAVY-DUTY MIXER

Approved by _____ Date _____ Approved by _____ Date _____



HL400 LEGACY+ 40-Quart Maximum Heavy-Duty Mixer

SOLUTIONS/BENEFITS

PERFORMANCE

VFDadvantage Variable Frequency Drive

- + All-gear, direct drive system
- + Ensures superior mixing consistency, motor protection and long life

Quick Release™ Agitators

- + Eliminates the up/down play of bayonet-style agitators
- + Consistent agitator-to-bowl ratio delivers superior mixing performance

Four Mixing Speeds

- + Can handle virtually any mixing job
- + Includes stir speed

Reinforced Planetary Shaft System

- + Rugged durability under the most challenging mixing conditions

Maximum Capacity Overheat Protection

- + Extreme-duty wiring and connections handle more power, reducing thermal cycling impact

EASE OF USE

Ergonomic Swing-Out Bowl

- + Easily swing bowl to the side to remove/add ingredients
- + Adds convenience and saves time

Single-Point Bowl Installation

- + Easy-to-mount bowl uses only one point to install
- + Reduces risk of spills, speeds up mixing process

Bowl Lift

- + Ergonomic, smoothly moves bowl into mixing position

Shift-on-the-Fly™ Controls

- + Allows safe, convenient speed changes while the motor is running
- + Pulse and jog as needed

20-Minute SmartTimer™

- + Automatic recall of time and speed

SANITATION & CLEANING

Stainless Steel Removable Bowl Guard

- + Easy to remove without tools for cleaning
- + Dishwasher-safe for easy cleaning and sanitizing

Soft Start Agitation Technology

- + Gradually delivers electricity to the mixer
- + Minimizes the risk of ingredient splash out

OPERATOR ASSURANCE

Triple Interlock System with MagnaLock Technology

- + Prevents mixer from operating unless the bowl is fully up and locked in place and the bowl guard is secured

HL400 MIXER CAPACITY CHART

Recommended Maximum Capacities – dough capacities based on 70°F water and 12% flour moisture.

Product	Agitators Suitable for Operation	HL400
Capacity of Bowl (Qt. Liquid)		40
Egg Whites	D	1¾ qt.
Mashed Potatoes	B & C	30 lb.
Whipped Cream	D or C	9 qt.
Cakes		40 lb.
Cookies, Sugar		30 lb.
Dough, Bread or Roll ★ (Lt.-Med.) 60% AR	ED	45 lb. ●
Dough, Heavy Bread 55% AR ★	ED	35 lb. ●
Dough, Thin Pizza 40% AR ★ (max. mix time 5 min.)	ED	25 lb. ●
Dough, Thick Pizza 60% AR ★	ED	45 lb. ●
Dough, Whole Wheat 70% AR	ED	45 lb. ●
Icing, Fondant	B	25 lb.
Icing, Marshmallow	C or I	4½ lb.
Pasta, Basic Egg Noodle (max. mix time 5 min.)	ED	15 lb. ●

Note: % AR (% Absorption Ratio) – Water weight divided by flour weight. Capacity depends on moisture content of dough. Above capacities based on 12% flour moisture at 70°F water temperature.

● 1st Speed

■ 2nd Speed

▲ 3rd Speed

★ If high gluten flour is used, reduce above dough batch size by 10%.

2nd speed should never be used on 50% AR or lower products.

Use of ice requires a 10% reduction in batch size.

1 gallon of water weighs 8.33 lbs.

Note: Attachment hub should not be used while mixing.



HL400 LEGACY+ 40-Quart Maximum Heavy-Duty Mixer

SPECIFICATIONS

Motor: 1½ HP high torque motor.

200-240/50/60/1 – 9.3 Amps

200-240/50/60/3 – 5.6 Amps

380-460/50/60/3 – 2.7 Amps

Electrical: 200-240/50/60/1, 200-240/50/60/3 and 380-460/50/60/3 – UL Listed.

Controls: Magnetic contactor and thermal overload protection. Internally sealed “Start-Stop” push buttons. A 20-minute SmartTimer™ is standard. SmartTimer™ includes:

- **Automatic Time Recall**, which remembers the last time set for each speed.
- **Transmission:** Gear-driven. Gears are constant mesh heat-treated hardened alloy steel along with anti-friction ball bearings. Grease lubricants furnished to all gears and shafts.

Speeds	Agitator (RPM)	Attachment (RPM)
Stir	58	34
First (Low)	96	56
Second (Intermediate)	179	104
Third (High)	319	185

Bowl Guard: Heavy-duty stainless steel wire front and solid rear portion. Front portion of guard rotates easily to add ingredients and install or remove agitator. It detaches in seconds for cleaning in dishwasher or sink. Rear portion of guard can be quickly cleaned in position. Guard must be in closed position before mixer will operate. Bowl support interlock provides further protection.

Bowl Lift: Ergonomic style, manual operated, self-locking in top and bottom position.

Finish: Metallic gray hybrid powder coat finish.

Attachment Hub: Comes with front-mounted Hobart standard #12 taper attachment hub for use with Hobart #12 size attachments.

Warranty: Unit has full one-year warranty on parts, labor and mileage against manufacturer's defects. Service contracts are available.

Attachments and Accessories:

The following are available at extra cost:

Attachment / Accessory	Device #
Stainless Steel Bowl	BOWL-HL40
“B” Flat Beater	BBEATER-HL4030
“C” Wing Whip	CWHIP-HL4030
“D” Wire Whip	DWHIP-HL4030
“ED” Dough Hook	EDDOUGH-HL40SS
“P” Pastry Knife	PPASTRY-HL4030
“I” Heavy Duty Wire Whip	IWIRE-HL4030
Bowl Splash Cover (lexan)	SPLASH-LEX040
Bowl Scraper	SCRAPER-HL40
Ingredient Chute	CHUTE-HL4030
Bowl Truck	TRUCK-HL4030
Stainless Steel Feet	PADSST-HL4320
9" Vegetable Slicer	VS9
Meat Chopper Attachment	12TIN-C/EPAN
20 Quart Accessories	See HL200 spec sheet
30 Quart Accessories	See HL300 spec sheet

Plugs and Receptacles:

Dependent on local power codes

HL400	Machine Voltages			
	200-240	230/60/1	200-240	380-460
Service Current Requirement if Plug Connected	200/60/1 208/60/1	230/60/1	230/60/3	460/60/3
Terminal Designation of Plug		2 Pole 3 Wire Grounding	3 Pole 4 Wire Grounding	3 Pole 4 Wire Grounding
NEMA Plug Configuration		6-15P	L15-20P	L16-20P
Plug Configuration				
Molded Plug on Cord		Yes	No	No
Plug - Straight/ Angle		Straight	Straight	Straight
NEMA Receptacle or Connector Configuration		6-15R	L15-20R	L16-20R
Power Cord Included	No	No	No	No



HL400 LEGACY+ 40-Quart Maximum Heavy-Duty Mixer

DETAILS AND DIMENSIONS

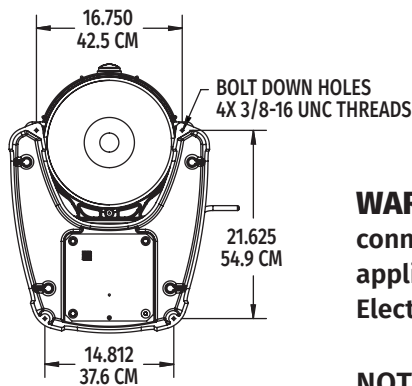
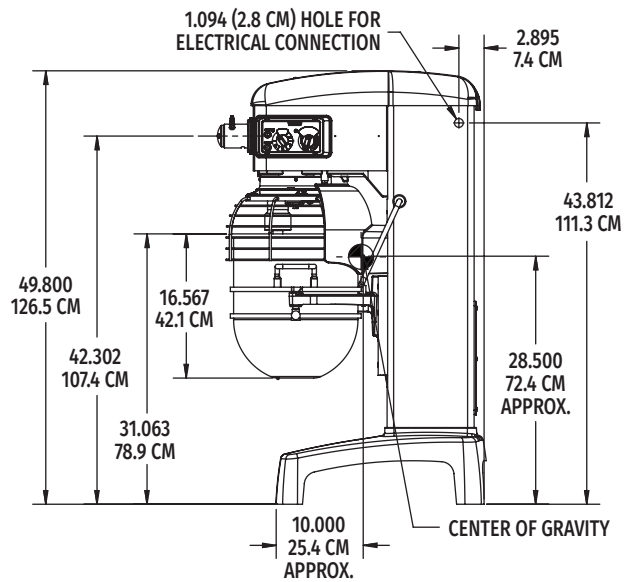
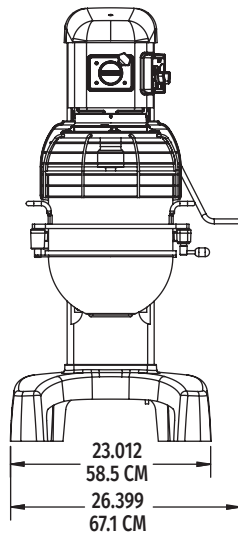
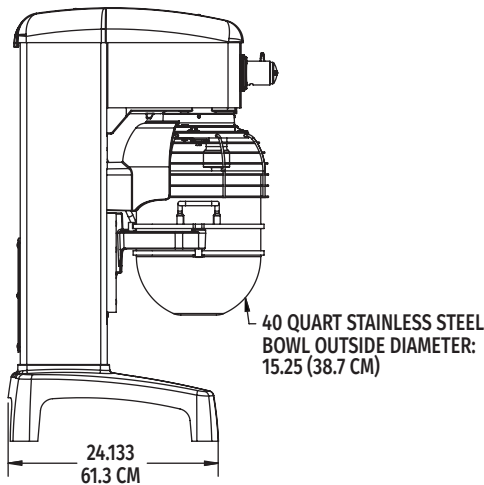
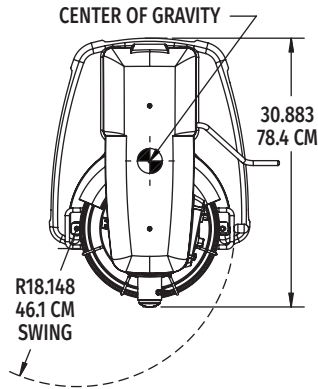

WARNING: Electrical and grounding connections must comply with the applicable portions of the National Electrical Code and/or other codes in force.

NOTE:
Machine Weight (Less Bowl): 387 lbs. (175.5 kg)
Shipping Weight: 453 lbs. (205.5 kg)
Bowl Weight: 18 lbs. (8.2 kg)