



161 K

SP G

Single Flavor
Counter Top
Shake Machine



Performance and Quality Add Shakes to any location with this compact model. Superior performance compared to other machines in the same category. The H-O-T system allows users to set the desired consistency for classic milkshakes or creamy modern shakes. The innovative direct-drive motor is the most silent in its class.



Convenience The user-friendly display is easy to use by novice operators. Audible Signal alerts when a refill is needed. Adjustable delivery flow to meet diverse volume & speed needs.



Savings Optimized Installation space, thanks to the vertical ventilation system making it possible to fit the machine beside other equipment. Single-phase machine makes it easy to fit into most locations.



Safety Heat treatment ensures the utmost hygiene. the shelf life of the liquid mix. Built-in memory provides pinpoint a diagnosis. The Tank Agitator prevents product stratification & improves heat exchange during Heat treatment.



*request the kits from your distributor to maintain your machine hygienically clean.

carpigiani.com/us

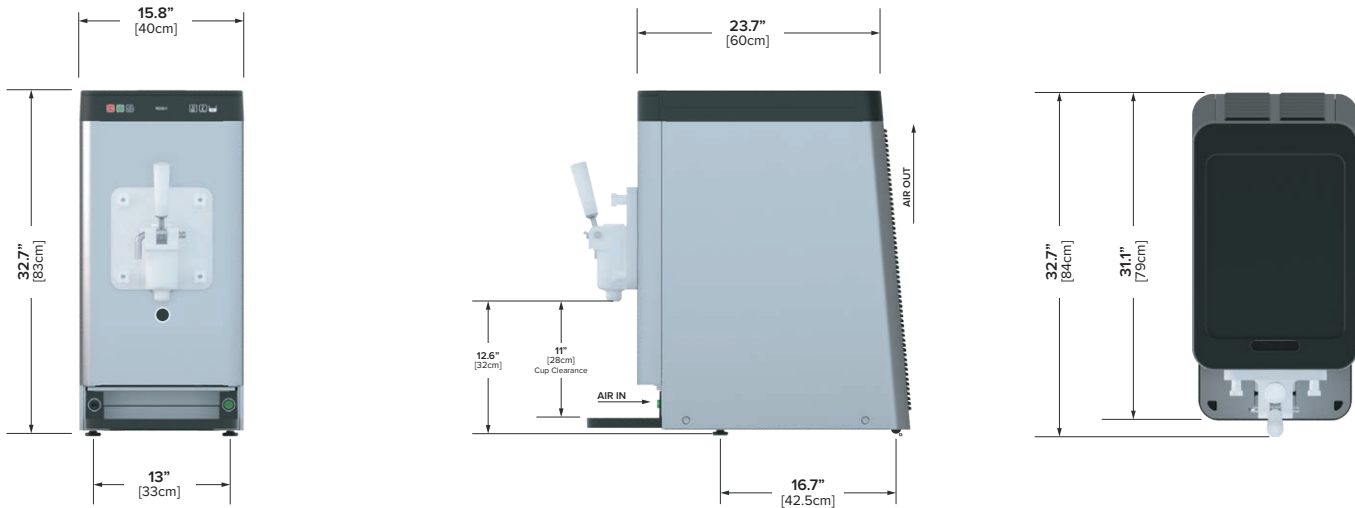

AIR

Weights	lbs.	kgs.	
Net	220	100	
Crated	282	128	
Volume	cu. ft.	cu. m.	
Volume	19.78	0.56	
Dimensions	in.	cm.	
Width	15.8	40	
Depth	32.7	84	
Height	32.7	83	
Electrical	Maximum Fuse Size	Minimum Circuit Ampacity	Poles (P) Wires (W)
220-230/60/1 Air	16A	10.5A	2W+G

Specifications

Electrical

A dedicated electrical connection is required. Manufactured to be permanently connected. See the Electrical chart for the proper electrical requirements. Consult your local Carpigiani distributor for cord & receptacle specifications as local codes allow.

Beater Motor

0,88 HP

Refrigeration System

R290

Air Cooled *

Minimum clearance: 2" (5 cm) on both side panels and 0" (0 cm) from the rear panel for proper air circulation.

Hopper Capacity

19 quarts (18 liters)

All specifications mentioned must be considered approximate; Carpigiani reserves the right to modify, without notice, all parts deemed necessary. This unit may be manufactured in other electrical characteristics and may have additional regulatory agency approvals, please consult the local Carpigiani Distributor. Check name plate for exact electrical data. * Room temperature 68 °F (20 °C).

Bidding Specs

Electrical Volt _____ Hz _____ Ph _____ Neutral Yes No Cooling Air Water

Options _____



738 Gallimore Dairy Road, Suite 113
High Point, NC - 27265
Toll free (800) 648 4389



Dealer

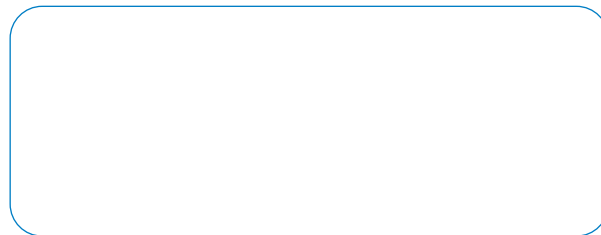

www.bipluci.it | printed 11/2022

an Ali Group Company



The Spirit of Excellence