



VACUUM PACKAGING

## COUNTERTOP ECONOMY VACUUM PACKAGING MACHINE

Item #: 19481 / 19842

Model: VP-CN-0749 / VP-CN-1066

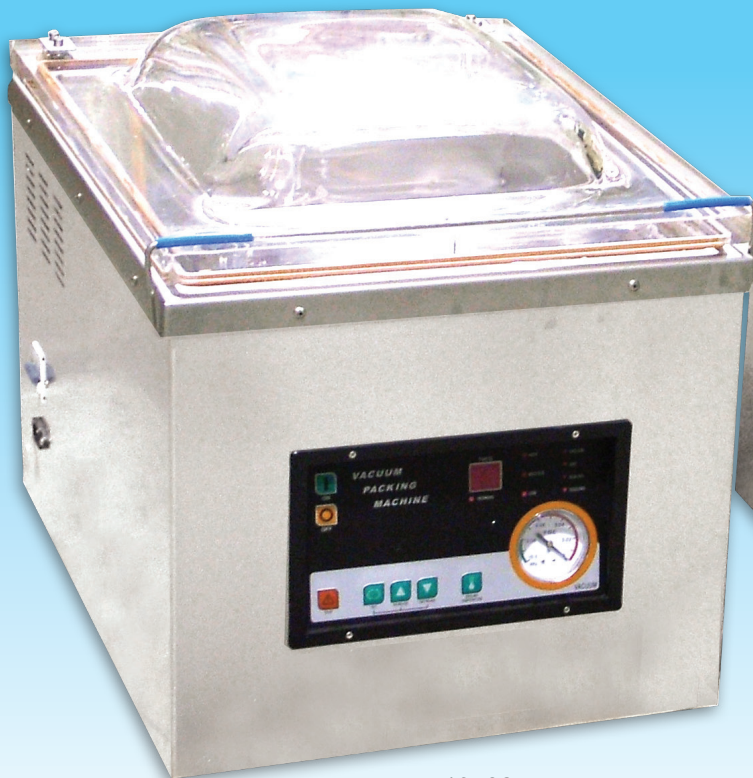

19482  
Model: VP-CN-1066



19481  
Model: VP-CN-0749



Authorized Dealer

# VACUUM PACKAGING

## COUNTERTOP ECONOMY VACUUM PACKAGING MACHINE



### Countertop Economy Vacuum Packaging Machines

These vacuum packaging machines are ideal for a variety of applications. The machines are equipped with a digital control panel that controls the sealing temperature, sealing time, drawing air time, and cooling time. Once the lid is closed, the machine automatically starts the sealing process.

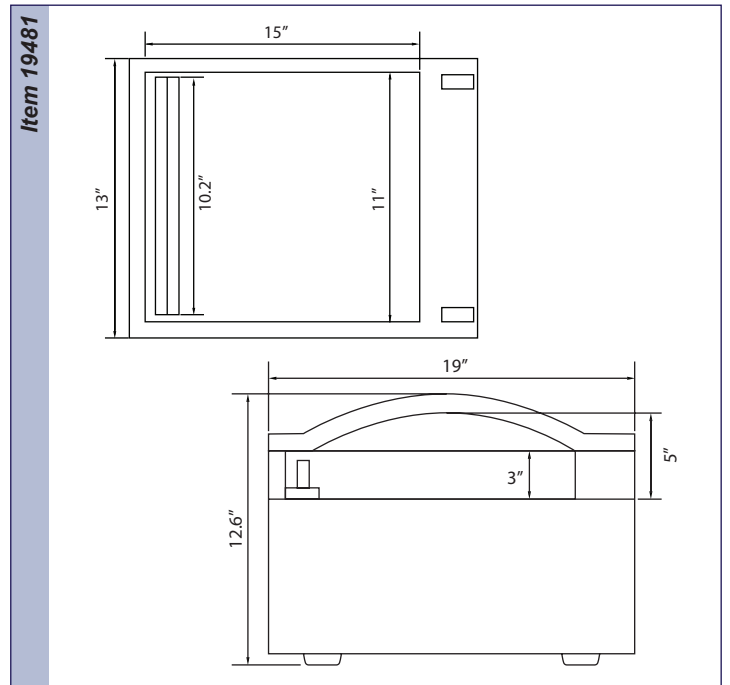
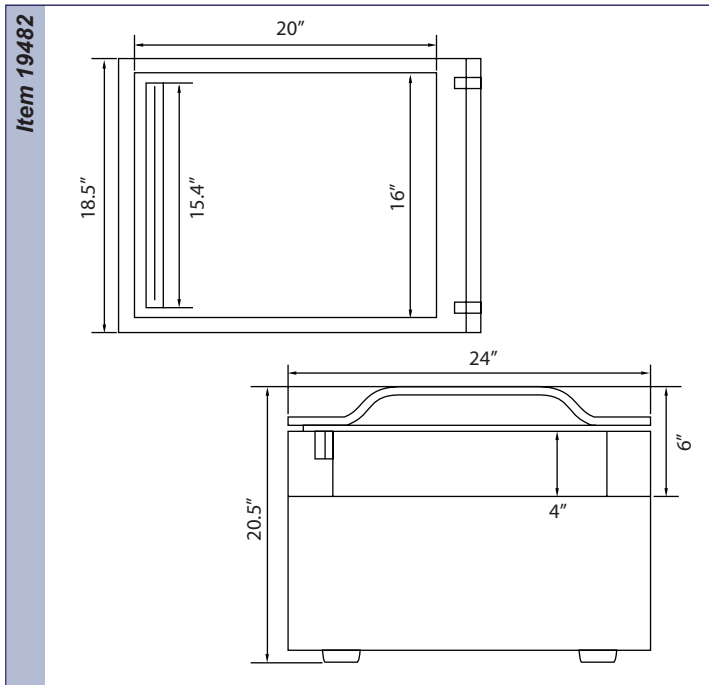

TECHNICAL SPECIFICATION	Countertop Economy Vacuum Packaging Machine with 1.2 HP	Countertop Economy Vacuum Packaging Machine with ½ HP
ITEM NUMBER	19482	19481
MODEL	VP-CN-1066	VP-CN-0749
POWER	0.9 kw / 1.2 HP	0.37 kw / 0.5 HP
SEAL BAR	15.4" x 0.31" / 39cm x 0.8cm	10.2" x 0.31" / 26cm x 0.8cm
CYCLE TIME	23-25 seconds	30 seconds
PUMP POWER	20 m <sup>3</sup> /h	10 m <sup>3</sup> /h
CHAMBER SIZE	20" x 16" x 4" / 51cm x 40.6cm x 10.16cm	15" x 11" x 3.15" / 18cm x 28cm x 8cm
ELECTRICAL	110V / 60 / 1	110V / 60 / 1
WEIGHT	96.8 lbs / 44kg.	79.2 lbs / 36kg.
DIMENSIONS (DWH)	24" x 18.5" x 20.5" / 61cm x 47cm x 52cm	19" x 13" x 12.6" / 48cm x 33cm x 32cm
PACKAGING DIMENSIONS	27" x 21" x 22" / 68.6cm x 53cm x 56cm	22" x 17" x 15" / 55.9cm x 43cm x 38cm

(We carry all size of vacuum packaging bags for the above models.)

### OMCAN INC.

Telephone: 1-800-465-0234  
 Fax: (905) 607-0234  
 E-mail: sales@omcan.com  
 Website: www.omcan.com



Follow us to keep up to date with the latest news and offers

