

Kit adattatori pedane / Footpeg adjuster kit - 96280511A
Kit pedane Pro - 96280501AA (Nero) - 96280501AB (Argento)
Pro footpeg kit - 96280501AA (Black) - 96280501AB (Silver)
Kit pedane poggiapiedi in alluminio / Aluminium footpeg kit - 96280561AA

Simbologia

Per una lettura rapida e razionale sono stati impiegati simboli che evidenziano situazioni di massima attenzione, consigli pratici o semplici informazioni. Prestare molta attenzione al significato dei simboli, in quanto la loro funzione è quella di non dovere ripetere concetti tecnici o avvertenze di sicurezza. Sono da considerare, quindi, dei veri e propri "promemoria". Consultare questa pagina ogni volta che sorgessero dubbi sul loro significato.



Attenzione

La non osservanza delle istruzioni riportate può creare una situazione di pericolo e causare gravi lesioni personali e anche la morte.



Importante

Indica la possibilità di arrecare danno al veicolo e/o ai suoi componenti se le istruzioni riportate non vengono eseguite.



Note

Fornisce utili informazioni sull'operazione in corso.

Riferimenti

I particolari evidenziati in grigio e riferimento numerico (Es. ①) rappresentano l'accessorio da installare e gli eventuali componenti di montaggio forniti a kit.

I particolari con riferimento alfabetico (Es. Ⓐ) rappresentano i componenti originali presenti sul motoveicolo.

Tutte le indicazioni destro o sinistro si riferiscono al senso di marcia del motociclo.

Avvertenze generali



Attenzione

Le operazioni riportate nelle pagine seguenti devono essere eseguite da un tecnico specializzato o da un'officina autorizzata Ducati.



Attenzione

Le operazioni riportate nelle pagine seguenti se non eseguite a regola d'arte possono pregiudicare la sicurezza del pilota.



Note

Documentazione necessaria per eseguire il montaggio del Kit è il Manuale Officina, relativo al modello di moto in vostro possesso.



Note

Nel caso fosse necessaria la sostituzione di un componente del kit consultare la tavola ricambi allegata.

Symbols

To allow quick and easy consultation, this manual uses graphic symbols to highlight situations in which maximum care is required, as well as practical advice or information. Pay attention to the meaning of the symbols since they serve to avoid repeating technical concepts or safety warnings throughout the text. The symbols should therefore be seen as real reminders. Please refer to this page whenever in doubt as to their meaning.



Warning

Failure to follow these instructions might give rise to a dangerous situation and provoke severe personal injuries or even death.



Caution

Failure to follow these instructions might cause damages to the vehicle and/or its components.



Notes

Useful information on the procedure being described.

References

Parts highlighted in grey and with a numeric reference (Example ①) are the accessory to be installed and any assembly components supplied with the kit.

Parts with an alphabetic reference (Example Ⓐ) are the original components fitted on the vehicle.

Any right- or left-hand indication refers to the vehicle direction of travel.

General notes



Warning

Carefully perform the operations on the following pages since they might negatively affect rider safety.



Warning

Carefully perform the operations on the following pages since they might negatively affect rider safety.



Notes

The following documents are necessary for assembling the Kit: Workshop Manual of your bike model.



Notes

Should it be necessary to change any kit parts, please refer to the attached spare part table.



Warning

Operating, servicing and maintaining a passenger vehicle or off-highway motor vehicle can expose you to chemicals including engine exhaust, carbon monoxide, phthalates, and lead, which are known to the State of California to cause cancer and birth defects or other reproductive harm. To minimize exposure, avoid breathing exhaust, do not idle the engine except as necessary, service your vehicle in a well-ventilated area and wear gloves or wash your hands frequently when servicing your vehicle. For more information go to www.P65Warnings.ca.gov/passenger-vehicle.

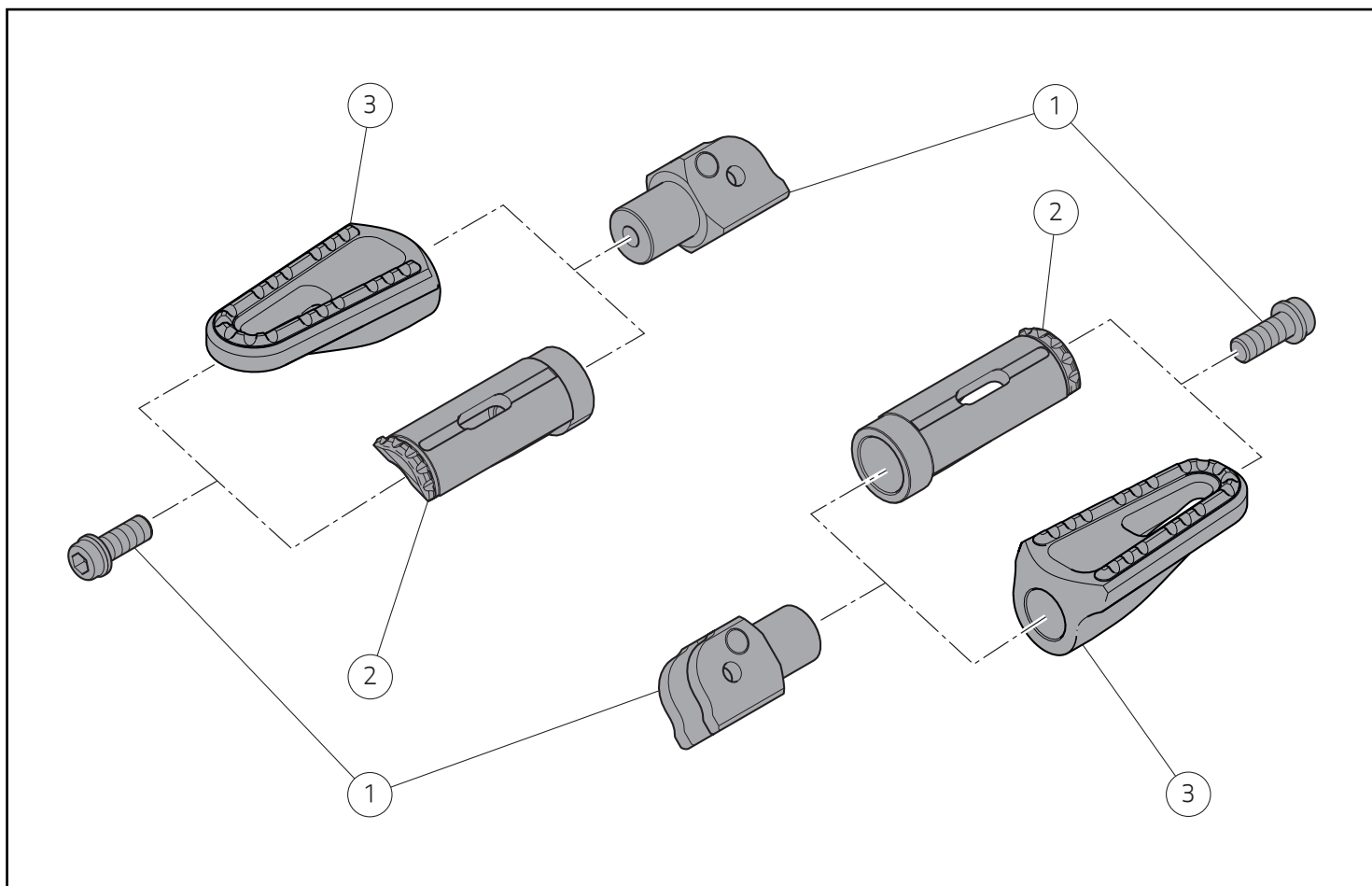

Pos.	Denominazione	Description
1	Kit adattatori pedane	Footpeg adjuster kit
2	Kit pedane Pro (Hypermotard - Supersport - Monster - Multistrada - Superbike)	Pro footpeg kit (Hypermotard - Supersport - Monster - Multistrada - Superbike)
3	Kit pedane poggiapiedi in alluminio (Scrambler)	Aluminium footpeg kit (Scrambler)

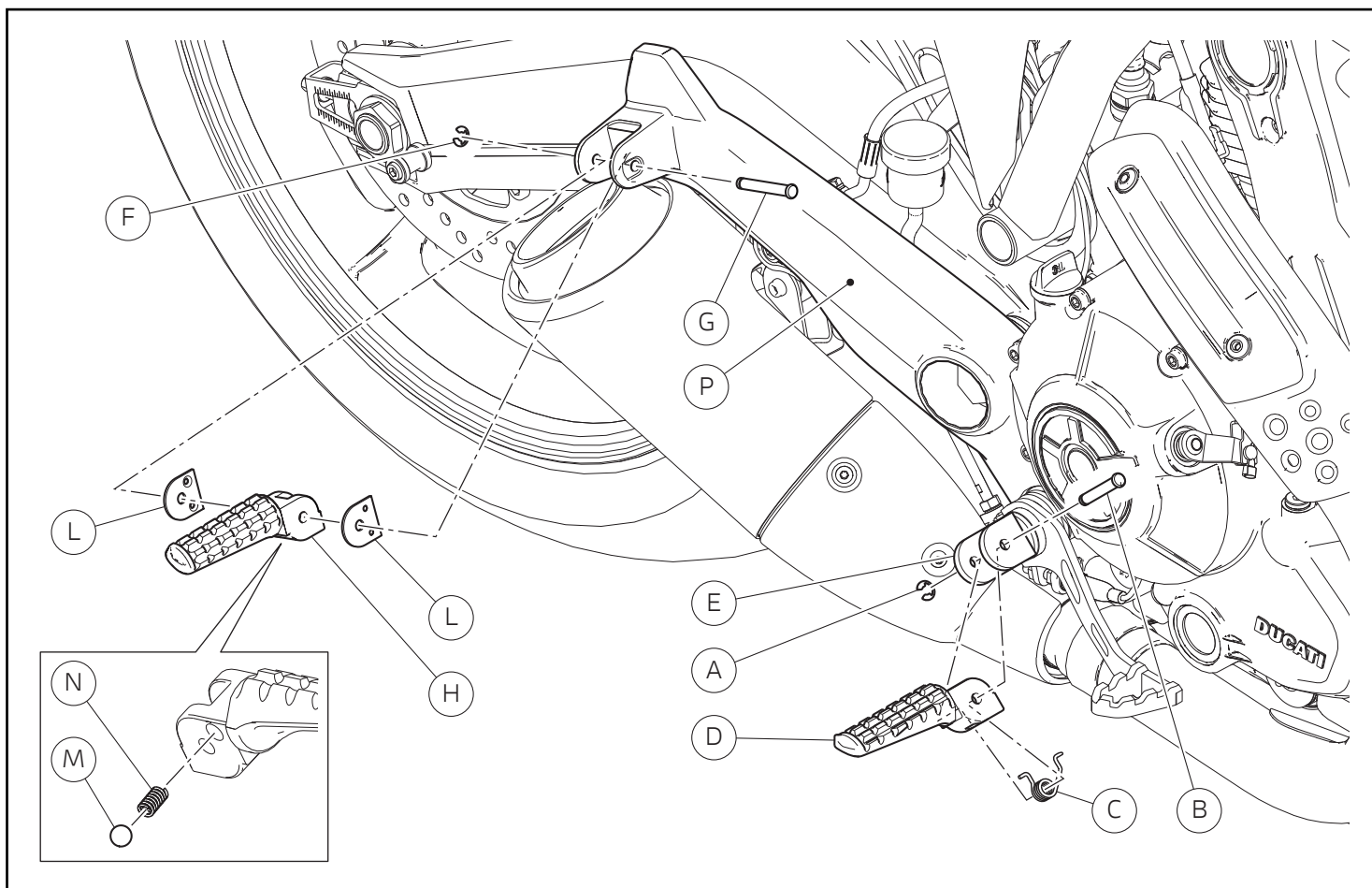

Smontaggio componenti originali

Smontaggio pedane destre

Operando sul lato destro del motoveicolo smontare l'anello di sicurezza (A) e sfilare il perno (B). Rimuovere la pedana destra (D) e la molla (C) dal supporto pedana anteriore (E). Recuperare l'anello di sicurezza (A), il perno (B) e la molla (C).

Smontare l'anello elastico (F) e sfilare il perno (G) dalla piastra portapedana destra (P). Rimuovere la pedana destra (H) e le n.2 piastrelle arresto pedana (L), prestando attenzione alla molla (N). Smontare la sfera (M) e la molla (N) dalla pedana destra (H). Recuperare tutti i componenti.

Ripetere la stessa operazione per lo smontaggio delle pedane sinistre.

Removing the original components

RH footpeg disassembly

By working on RH side of the motorcycle, disassemble safety ring (A) and slide out pin (B). Remove the RH footpeg (D) and the spring (C) from the front footpeg support (E). Keep the safety ring (A), the pin (B) and the spring (C).

Remove snap ring (F) and pull out pin (G) from RH footpeg holder plate (P). Remove RH footpeg (H) and no. 2 footpeg stop plates (L), paying attention to spring (N). Remove ball (M) and spring (N) from RH footpeg (H). Keep all components.

Repeat the same procedure to remove LH footpegs.

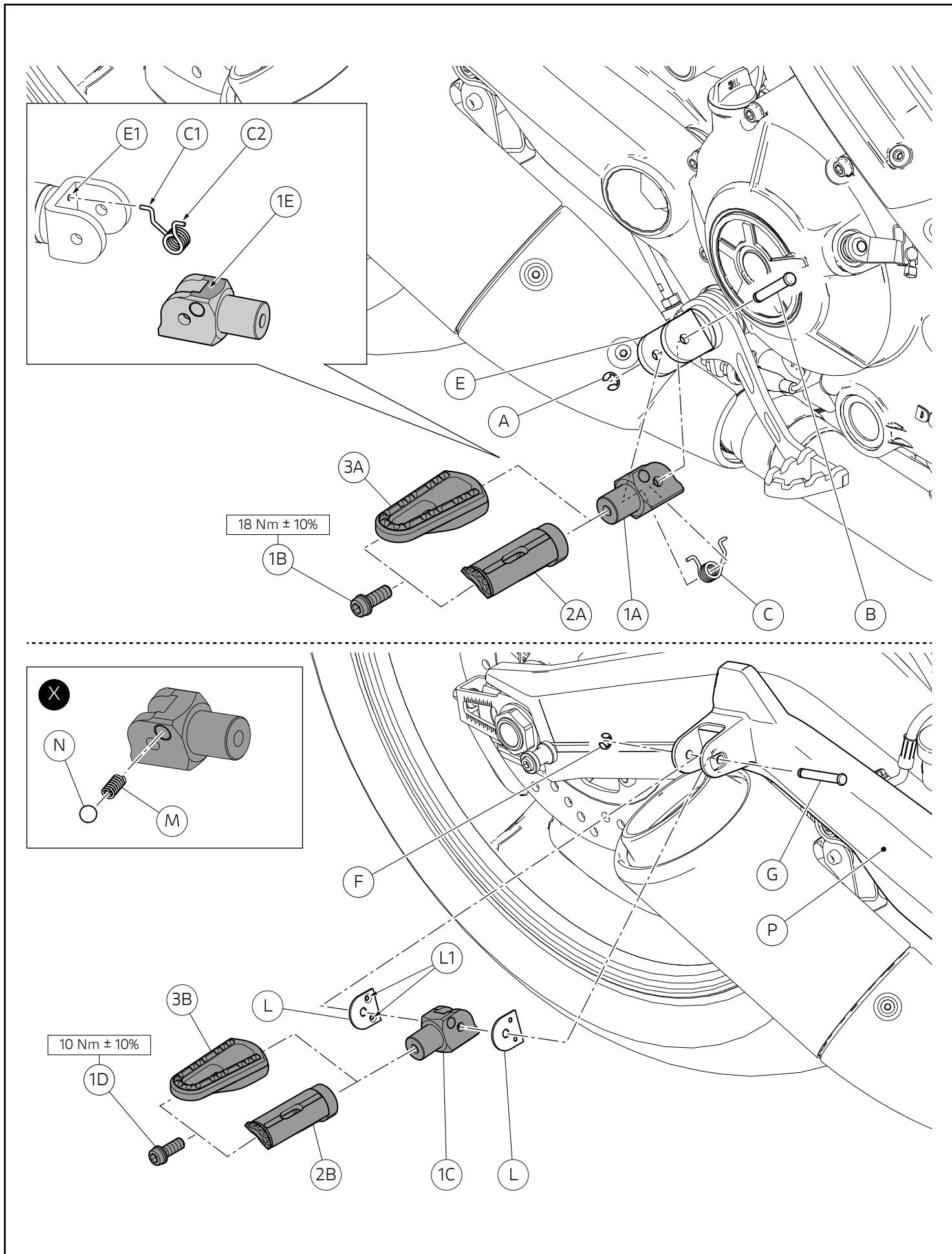

Montaggio componenti kit



Importante

Verificare, prima del montaggio, che tutti i componenti risultino puliti e in perfetto stato. Adottare tutte le precauzioni necessarie per evitare di danneggiare qualsiasi parte nella quale ci si trova ad operare.

Montaggio pedana anteriore destra

Applicare grasso Shell Retinax HD2 sul perno originale (B). Montare la molla originale (C) sul supporto pedana anteriore (E), orientandola come mostrato in figura, inserendo l'estremità (C1) della molla (C) nel foro (E1), come indicato nel riquadro. Montare la leva (1A) sul supporto pedana anteriore (E), posizionando l'altra estremità (C2) della molla (C) sulla superficie (1E). Inserire il perno (B), sul supporto pedana anteriore (E) e bloccarlo utilizzando l'anello elastico originale (A). Montare la pedana (2A) - (3A) sulla leva (1A) e impuntare la vite (1B). Serrare la vite (1B) alla coppia indicata. Verificare il corretto funzionamento della pedana destra anteriore.

Ripetere la stessa operazione per il montaggio della pedana anteriore sinistra.

Montaggio pedana posteriore destra

Applicare grasso Shell Retinax HD2 alla molla (N). Inserire la molla (N) e la sfera (M) nell'apposito foro della leva (1C). Posizionare le n.2 piastrine arresto pedana (L) sulla leva (1C), orientandole come mostrato in figura.



Importante

Orientare le n.2 piastrine arresto pedana (L) con le svasature dei fori (L1) rivolte verso la leva (1C).

Applicare grasso SHELL Retinax HD2 sul perno (G). Introdurre la leva (1C) all'interno della piastra portapedana (E) e fissarla inserendo il perno (G). Bloccare il perno (G) utilizzando l'anello elastico originale (F). Montare la pedana (2B) - (3B) sulla leva (1C) e impuntare la vite (1D). Serrare la vite (1D) alla coppia indicata. Verificare il corretto funzionamento della pedana destra posteriore.

Ripetere la stessa operazione per il montaggio della pedana posteriore sinistra.

Kit installation



Caution

Check that all components are clean and in perfect condition before installation. Adopt any precaution necessary to avoid damages to any part of the motorcycle you are working on.

Front RH footpeg assembly

Apply Shell Retinax HD2 grease on original pin (B). Fit original spring (C) on front footpeg support (E), aiming it as shown in the figure, by inserting end (C1) of the spring (C) in hole (E1) as shown in the box. Fit lever (1A) on front footpeg support (E), positioning the other end (C2) of spring (C) on surface (1E). Fit pin (B) on front footpeg support (E) and lock it with the original snap ring (A). Fit footpeg (2A) - (3A) on lever (1A) and start screw (1B). Tighten screw (1B) to the specified torque. Make sure that front RH footpeg works properly.

Repeat the same procedure for front LH footpeg assembly.

Rear RH footpeg assembly

Apply Shell Retinax HD2 grease on spring (N). Fit spring (N) and ball (M) into the relevant hole of lever (1C). Place no. 2 footpeg stop plates (L) on lever (1C), aiming them as shown in the figure.



Caution

Position no. 2 footpeg stop plates (L) with hole countersinks (L1) facing lever (1C).

Apply Shell Retinax HD2 grease on pin (G). Fit lever (1C) inside footpeg holder plate (E) and fasten it by fitting pin (G). Lock pin (G) with original snap ring (F). Fit footpeg (2B) - (3B) on lever (1C) and start screw (1D). Tighten screw (1D) to the specified torque. Make sure that rear RH footpeg works properly.

Repeat the same procedure for rear LH footpeg assembly.

Kit adaptateurs repose-pieds / Kit Fußrasten-Adapter - 96280511A

Kit repose-pieds Pro - 96280501AA (Noir) - 96280501AB (Argent)

Kit Fußrasten Pro - 96280501AA (Schwarz) - 96280501AB (Silber)

Kit repose-pieds en aluminium / Kit Fußrasteneinheit aus Aluminium - 96280561AA

Symboles

Pour faciliter la consultation de ce manuel, des symboles signalent des situations exigeant le maximum d'attention, des conseils pratiques ou de simples informations. Lire attentivement la signification de ces symboles car ils renvoient à des concepts techniques ou des consignes de sécurité de la plus grande importance. Ils doivent être considérés comme de véritables « aide-mémoire ». Toujours consulter cette page en cas de doute concernant leur signification.



Attention

La non-observance des instructions reportées ci-dessous peut créer une situation dangereuse et provoquer de graves lésions personnelles voire la mort.



Important

Indique la possibilité d'endommager le véhicule et/ou ses composants si les instructions reportées ci-dessous ne sont pas suivies.



Remarques

Fournit des informations utiles sur l'opération en cours.

Références

Les pièces surlignées en gris et la référence numérique (Ex. ①) représentent l'accessoire à installer et les composants de montage éventuels fournis en kit.

Les pièces avec référence alphabétique (Ex. Ⓐ) représentent les composants d'origine présents sur le motocycle.

Toutes les indications droite ou gauche se réfèrent au sens de marche la moto.

Avertissements généraux



Attention

Les opérations indiquées dans les pages suivantes, au cas où elles ne seraient pas effectuées selon les règles de l'art pourraient compromettre la sécurité du pilote.



Attention

Les opérations indiquées dans les pages suivantes, au cas où elles ne seraient pas effectuées selon les règles de l'art pourraient compromettre la sécurité du pilote.



Remarques

La documentation nécessaire pour effectuer la pose du Kit est le : Manuel D'atelier, relatif au modèle de moto en votre possession.



Remarques

Au cas où il serait nécessaire d'effectuer le remplacement d'un composant du kit, il faudra consulter la planche relative aux pièces détachées ci-jointe.

Symbole

Zum schnellen und übersichtlichen Lesen werden Symbole verwendet, die außerordentlich wichtige Situationen, praktische Ratschläge oder auch nur einfache Informationen hervorheben. Der Bedeutung dieser Symbole ist besondere Aufmerksamkeit zu schenken, da sich hierdurch das ständige Wiederholen von technischen Konzepten oder Sicherheitshinweisen erübrigt. Sie stellen daher regelrechte „Merker“ dar. Diese Seite ist immer dann zur Hand zu nehmen, wenn Zweifel über die Bedeutung eines Symbols bestehen sollten.



Achtung

Eine Nichtbeachtung der hier wiedergegebenen Anweisungen kann Gefahrensituationen schaffen und zu schweren Verletzungen und auch zum Tod führen.



Wichtig

Weist darauf hin, dass bei Nichteinhaltung der hier wiedergegebenen Anweisungen die Möglichkeit für Schäden am Fahrzeug und/oder seiner Komponenten besteht.



Hinweis

Übermittelt nützliche Informationen zum betreffenden Arbeitsingriff.

Bezugsangaben

Die grau gekennzeichneten Bestandteile mit numerischem Bezug (Bsp. ①) geben das zu installierende Bestandteil und die eventuellen, im Kit enthaltenen Montagekomponenten wieder.

Die Bestandteile mit alphabetischem Bezug (Bsp. Ⓐ) geben die Original-Bestandteile wieder, die am Motorrad verbaut wurden.

Alle Angaben wie „rechts“ oder „links“ beziehen sich auf die Fahrtrichtung des Motorrads.

Allgemeine Warnhinweise



Achtung

Werden die auf den folgenden Seiten beschriebenen Arbeitsmaßnahmen nicht fachgerecht ausgeführt, kann sich dies auf die Sicherheit des Fahrers auswirken.



Achtung

Werden die auf den folgenden Seiten beschriebenen Arbeitsmaßnahmen nicht fachgerecht ausgeführt, kann sich dies auf die Sicherheit des Fahrers auswirken.



Hinweis

Für die Montage des Kits sind folgende Unterlagen erforderlich: Werkstatthandbuch, des sich in Ihrem Besitz befindlichen Motorrads.



Hinweis

Sollte sich der Austausch eines Bestandteils des Kits als erforderlich erweisen, ist dazu Bezug auf die beiliegende Ersatzteilliste zu nehmen.

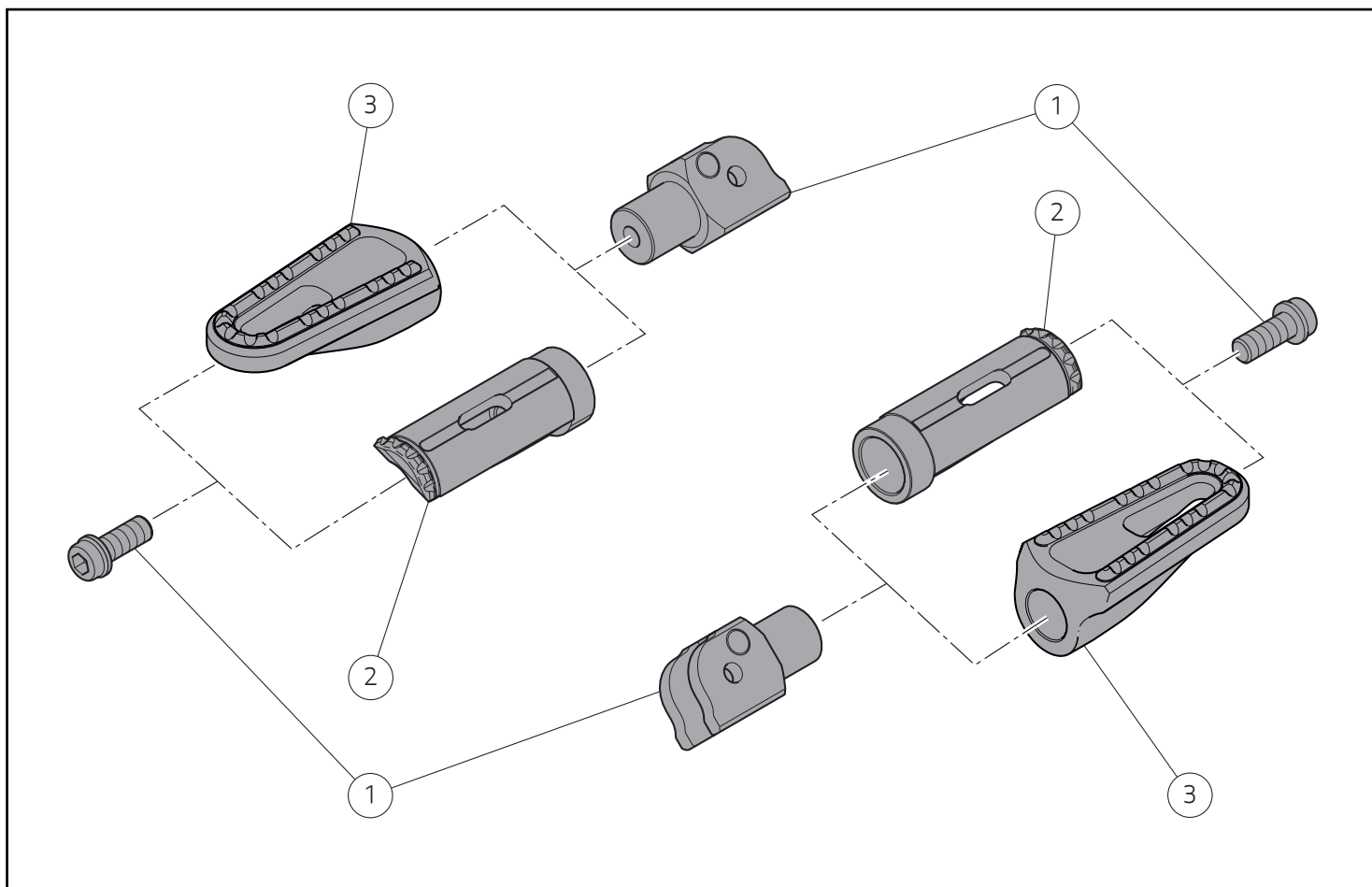

Pos.	Designation	Bezeichnung
1	Kit adaptateurs repose-pieds	Kit Fußrasten-Adapter
2	Kit repose-pieds Pro (Hypermotard - Supersport - Monster - Multistrada - Superbike)	Kit Fußrasten Pro (Hypermotard - Supersport - Monster - Multistrada - Superbike)
3	Kit repose-pieds en aluminium (Scrambler)	Kit Fußrasteneinheit aus Aluminium (Scrambler)

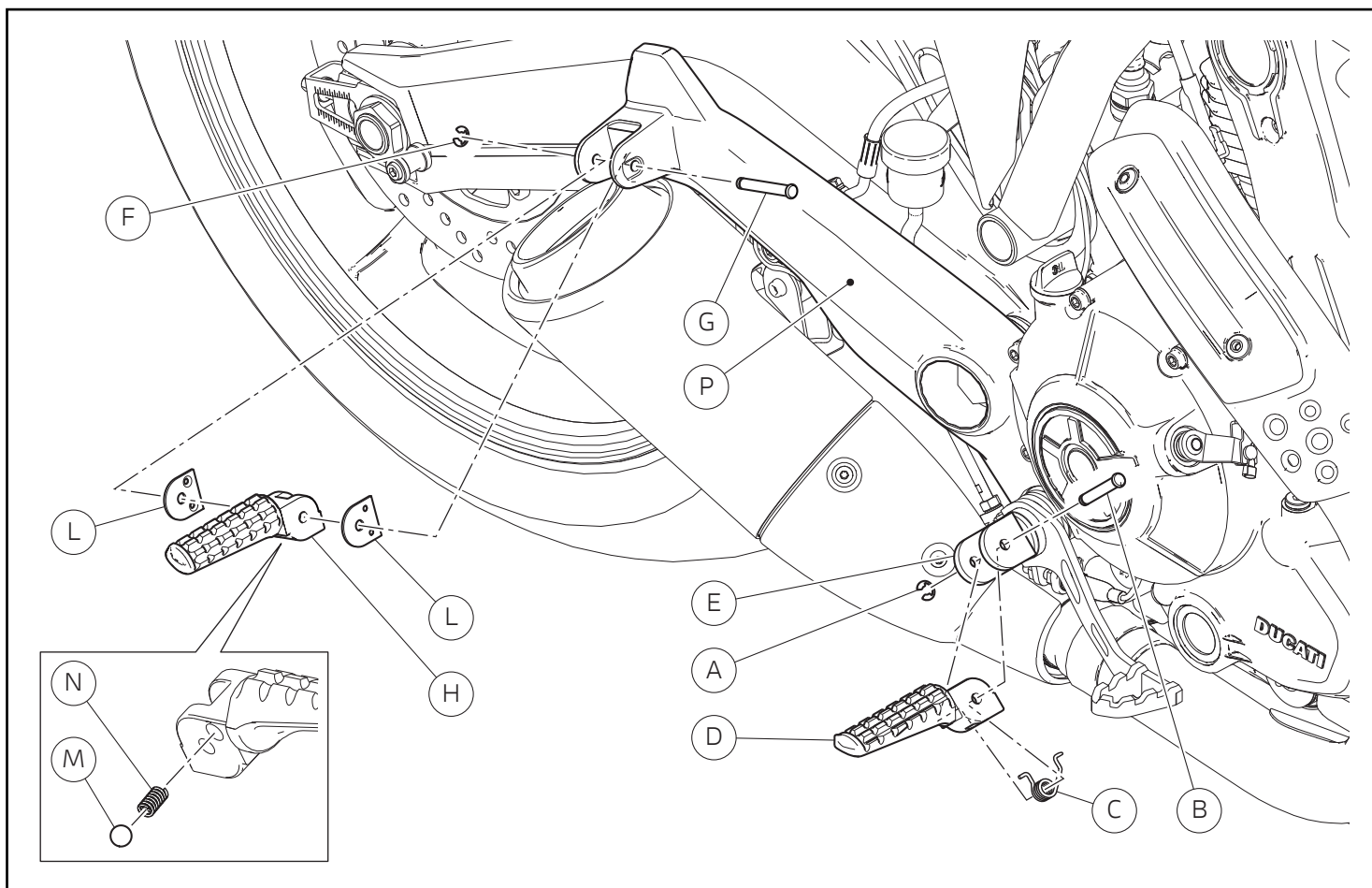

Dépose composants d'origine

Dépose repose-pieds droits

En agissant du côté droit du motorcycle, déposer le jonc d'arrêt (A) et sortir le pivot (B). Déposer le repose-pied droit (D) et le ressort (C) du support repose-pied avant (E). Récupérer le jonc d'arrêt (A), le pivot (B) et le ressort (C).

Déposer la bague à ressort (F) et sortir le pivot (G) de la platine de support repose-pied droit (P). Déposer le repose-pied droit (H) et les 2 plaquettes arrêt de repose-pied (L), en faisant attention au ressort (N). Déposer la bille (M) et le ressort (N) du repose-pied droit (H). Récupérer tous les composants.

Répéter la même opération pour la dépose des repose-pieds gauches.

Ausbau der Original-Bestandteile

Abnahme der rechten Fußrasten

An der rechten Seite des Motorrads den Sicherungsring (A) abmontieren und den Bolzen (B) herausziehen. Die rechte Fußraste (D) und die Feder (C) vom vorderen Fußrastenhalter (E) entfernen. Den Sicherungsring (A), den Bolzen (B) und die Feder (C) aufnehmen.

Den Drahtsprengling (F) ausbauen, dann den Bolzen (G) aus der rechten Fußrastenhalterplatte (P) herausziehen. Die rechte Fußraste (H) und die 2 Fußrastenklemmplättchen (L) entfernen und dabei auf die Feder (N) achten. Die Kugel (M) und die Feder (N) von der rechten Fußraste (H) lösen. Alle Komponenten aufnehmen.

Das gleiche Verfahren für die Abnahme der linken Fußrasten wiederholen.

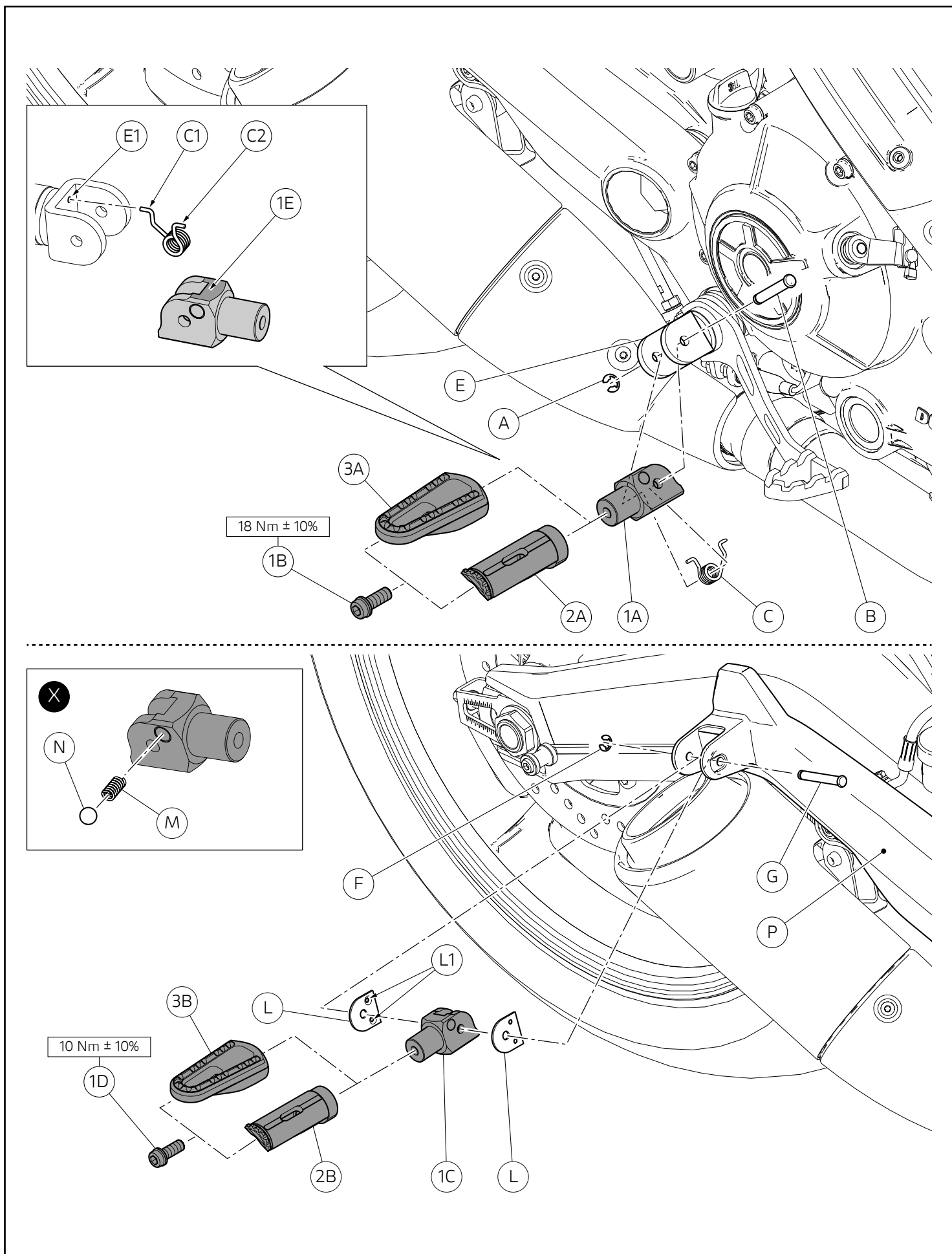

Pose composants kit

Important

Vérifier, avant la pose, que tous les composants sont propres et en parfait état. Adopter toutes les précautions nécessaires pour éviter d'endommager la surface externe des composants où on opère.

Pose repose-pied avant droit

Appliquer de la graisse Shell Retinax HD2 sur le pivot d'origine (B). Poser le ressort d'origine (C) sur le support repose-pied avant (E), en l'orientant comme la figure le montre et en insérant l'extrémité (C1) du ressort (C) dans le trou (E1), comme l'encadré le montre. Poser le levier (1A) sur le support repose-pied avant (E), en positionnant l'autre extrémité (C2) du ressort (C) sur la surface (1E). Insérer le pivot (B) sur le support repose-pied avant (E) et le bloquer à l'aide de la bague à ressort d'origine (A). Poser le repose-pied (2A) - (3A) sur le levier (1A) et présenter la vis (1B). Serrer la vis (1B) au couple prescrit. Vérifier le fonctionnement correct du repose-pied droit avant.

Répéter la même opération pour la pose du repose-pied avant gauche.

Pose repose-pied arrière droit

Appliquer de la graisse Shell Retinax HD2 sur le ressort (N). Insérer le ressort (N) et la bille (M) dans le trou du levier (1C) prévu à cet effet. Positionner les 2 plaquettes arrêt de repose-pied (L) sur le levier (1C), en les orientant comme la figure le montre.

Important

Positionner les 2 plaquettes arrêt de repose-pied (L) avec les fraises des trous (L1) orientées vers le levier (1C).

Appliquer de la graisse Shell Retinax HD2 sur le pivot (G). Insérer le levier (1C) à l'intérieur de la platine de support repose-pied (E) et le fixer à l'aide du pivot (G). Bloquer le pivot (G) avec la bague à ressort d'origine (F). Poser le repose-pied (2B) - (3B) sur le levier (1C) et présenter la vis (1D). Serrer la vis (1D) au couple prescrit. Vérifier le fonctionnement correct du repose-pied droit arrière.

Répéter la même opération pour la pose du repose-pied arrière gauche.

Montage der Komponenten des Kits

Wichtig

Vor der Montage überprüfen, dass sich alle Komponenten im sauberen und perfekten Zustand befinden. Alle erforderlichen Vorichtsmaßnahmen treffen, um eine Beschädigung der Oberflächen der Komponenten, die vom Eingriff betroffen sind, zu vermeiden.

Montage der vorderen rechten Fußraste

Das Fett Shell Retinax HD2 auf den Original-Bolzen (B) auftragen. Die Original-Feder (C) auf dem vorderen Fußrastenhalter (E) montieren und wie abgebildet ausrichten, dabei das Ende (C1) der Feder (C) in die Bohrung (E1), wie im Detailausschnitt dargestellt, einfügen. Den Hebel (1A) am vorderen Fußrastenhalter (E) montieren und dabei das Ende (C2) der Feder (C) an der Fläche (1E) anordnen. Den Bolzen (B) in den vorderen Fußrastenhalter (E) einfügen und mit dem Original-Drahtsprengring (A) feststellen. Die Fußraste (2A) - (3A) am Hebel (1A) montieren, dann die Schraube (1B) ansetzen. Die Schraube (1B) mit dem angegebenen Anzugsmoment anziehen. Die korrekte Funktionsweise der vorderen rechten Fußraste überprüfen.

Das gleiche Verfahren für die Montage der vorderen linken Fußraste wiederholen.

Montage der hinteren rechten Fußraste

Das Fett Shell Retinax HD2 auf die Feder (N) auftragen. Die Feder (N) und die Kugel (M) in die entsprechende Bohrung des Hebels (1C) einfügen. Die 2 Original-Fußrastenklemmplättchen (L) am Hebel (1C) anfügen und gemäß Abbildung ausrichten.

Wichtig

Die 2 Original-Fußrastenklemmplättchen (L) mit den spitzgesenkten Bereichen der Bohrungen (L1) in Richtung des Hebels (1C) ausrichten.

Das Fett Shell Retinax HD2 auf den Bolzen (G) auftragen. Den Hebel (1C) in die Fußrastenhalterplatte (E) fügen und durch Einfügen des Bolzens (G) befestigen. Den Bolzen (G) mit dem Original-Drahtsprengring (F) befestigen. Die Fußraste (2B) - (3B) am Hebel (1C) montieren, dann die Schraube (1D) ansetzen. Die Schraube (1D) mit dem angegebenen Anzugsmoment anziehen. Die korrekte Funktionsweise der hinteren rechten Fußraste überprüfen.

Das gleiche Verfahren für die Montage der hinteren linken Fußraste wiederholen.

Conjunto de adaptadores para patins / Footpeg adjuster kit - 96280511A

Conjunto de patins Pro - 96280501AA (Preto) - 96280501AB (Prata)

Pro footpeg kit - 96280501AA (Black) - 96280501AB (Silver)

Conjunto de patins pousa-pésem alumínio / Aluminium footpeg kit - 96280561AA**Símbolos**

Para uma leitura rápida e racional, foram utilizados símbolos que evidenciam situações de máxima atenção, conselhos práticos ou simples informações. Preste muita atenção ao significado dos símbolos, pois a sua função é a de evitar a repetição de conceitos técnicos ou de avisos de segurança. Portanto, os símbolos devem ser considerados como verdadeiros "lembretes". Consulte esta página sempre que tiver dúvidas acerca do seu significado.

**Atenção**

O não cumprimento das instruções mostradas pode criar uma situação de perigo e causar graves lesões pessoais e até mesmo a morte.

**Importante**

Indica a possibilidade de causar danos ao veículo e/ou aos seus componentes se as instruções mostradas não forem executadas.

**Notas**

Fornecer informações úteis sobre a operação em curso.

Referências

Os detalhes evidenciados em cinza e com referência numérica (Ex. ①) representam o acessório a ser instalado e os eventuais componentes de montagem fornecidos como kit.

Os detalhes com referência alfabética (Ex. A) representam os componentes originais presentes na moto.

Todas as indicações direita ou esquerda, referem-se ao sentido de marcha da moto.

Advertências gerais**Atenção**

As operações mostradas nas páginas a seguir, se não forem executadas com boa técnica, podem prejudicar a segurança do condutor.

**Atenção**

As operações mostradas nas páginas a seguir, se não forem executadas com boa técnica, podem prejudicar a segurança do condutor.

**Notas**

Documentação necessária para executar a montagem do Conjunto: Manual De Oficina, relativo ao modelo de moto em sua posse.

**Notas**

Caso seja necessária a substituição de um componente do conjunto, consulte o quadro de peças de reposição em anexo.

Symbols

To allow quick and easy consultation, this manual uses graphic symbols to highlight situations in which maximum care is required, as well as practical advice or information. Pay attention to the meaning of the symbols since they serve to avoid repeating technical concepts or safety warnings throughout the text. The symbols should therefore be seen as real reminders. Please refer to this page whenever in doubt as to their meaning.

**Warning**

Failure to follow these instructions might give rise to a dangerous situation and provoke severe personal injuries or even death.

**Caution**

Failure to follow these instructions might cause damages to the vehicle and/or its components.

**Notes**

Useful information on the procedure being described.

References

Parts highlighted in grey and with a numeric reference (Example ①) are the accessory to be installed and any assembly components supplied with the kit.

Parts with an alphabetic reference (Example A) are the original components fitted on the vehicle.

Any right- or left-hand indication refers to the vehicle direction of travel.

General notes**Warning**

Carefully perform the operations on the following pages since they might negatively affect rider safety.

**Warning**

Carefully perform the operations on the following pages since they might negatively affect rider safety.

**Notes**

The following documents are necessary for assembling the Kit: Workshop Manual of your bike model.

**Notes**

Should it be necessary to change any kit parts, please refer to the attached spare part table.

**Warning**

Operating, servicing and maintaining a passenger vehicle or off-highway motor vehicle can expose you to chemicals including engine exhaust, carbon monoxide, phthalates, and lead, which are known to the State of California to cause cancer and birth defects or other reproductive harm. To minimize exposure, avoid breathing exhaust, do not idle the engine except as necessary, service your vehicle in a well-ventilated area and wear gloves or wash your hands frequently when servicing your vehicle. For more information go to www.P65Warnings.ca.gov/passenger-vehicle.

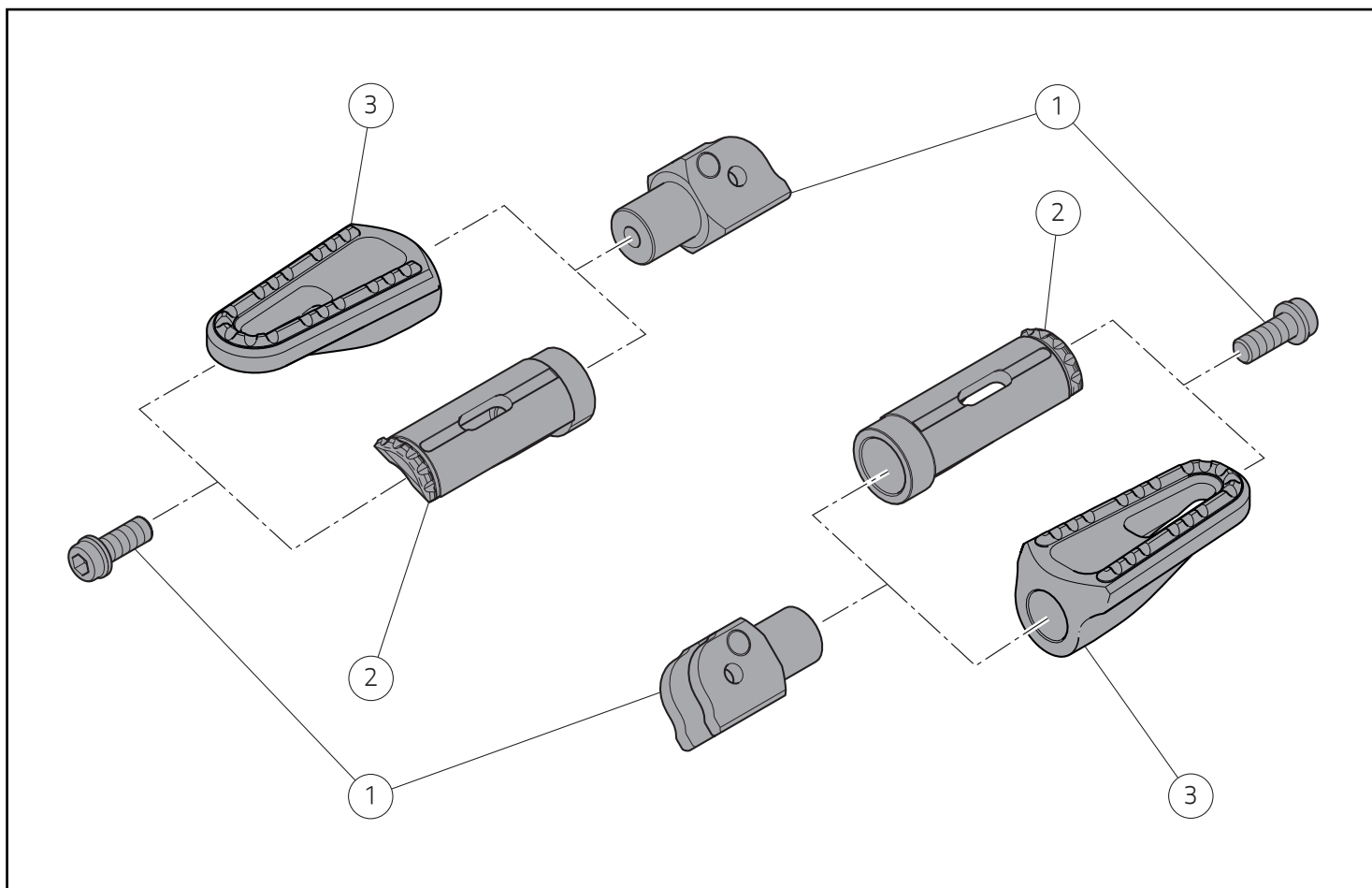

Pos.	Descrição	Description
1	Conjunto de adaptadores para patins	Footpeg adjuster kit
2	Conjunto de patins Pro (Hypermotard - Supersport - Monster - Multistrada - Superbike)	Pro footpeg kit (Hypermotard - Supersport - Monster - Multistrada - Superbike)
3	Conjunto de patins pouso-pésem alumínio (Scrambler)	Aluminium footpeg kit (Scrambler)

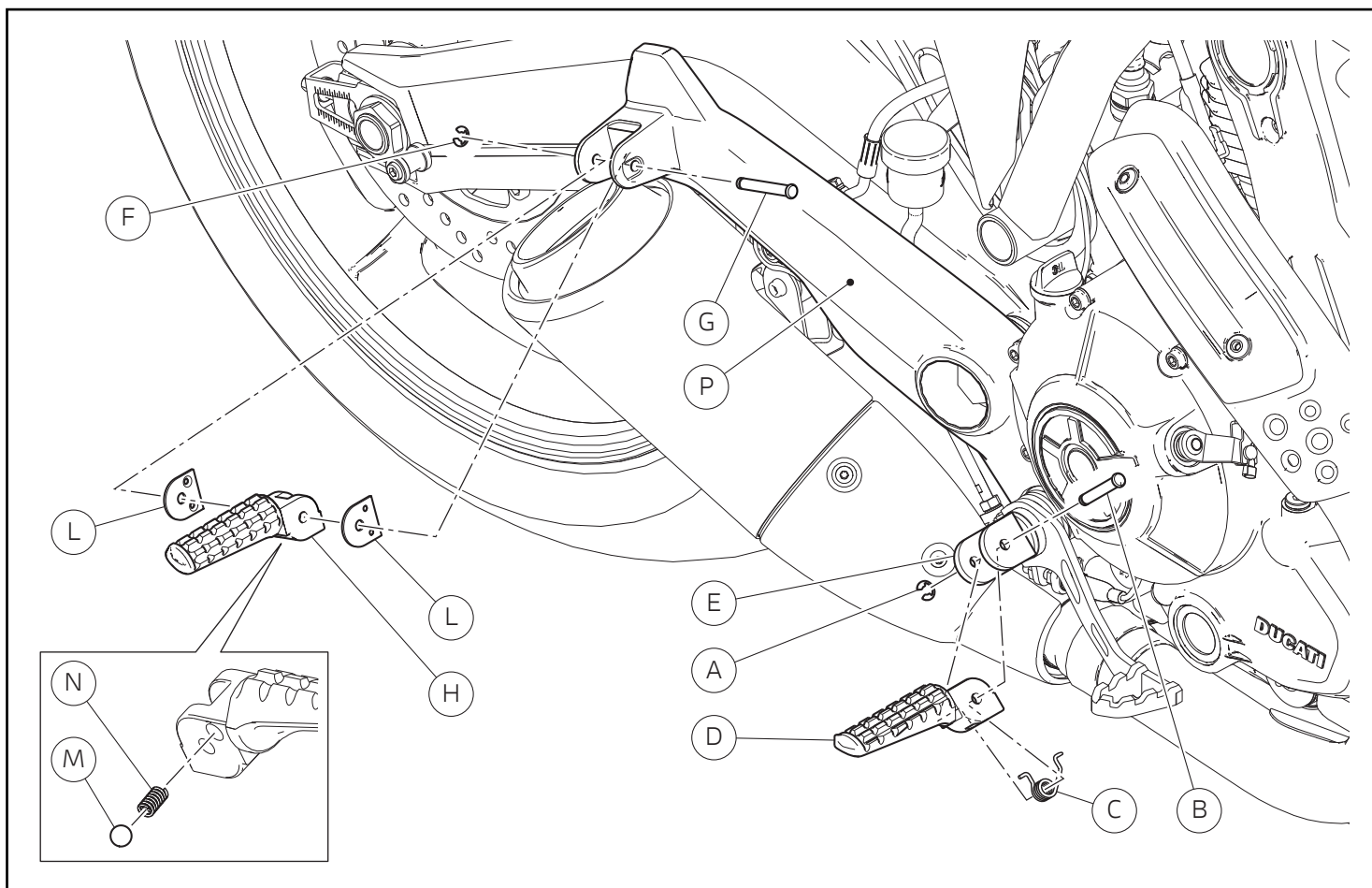

Desmontagem dos componentes originais

Removing the original components

Desmontagem dos patins direitos

Atuando no lado direito da moto, desmonte o anel de segurança (A) e retire o perno (B). Remova o patim direito (D) e a mola (C) do suporte do patim dianteiro (E). Guarde o anel de segurança (A), o perno (B) e a mola (C).

RH footpeg disassembly

By working on RH side of the motorcycle, disassemble safety ring (A) and slide out pin (B). Remove the RH footpeg (D) and the spring (C) from the front footpeg support (E). Keep the safety ring (A), the pin (B) and the spring (C).

Desmonte o anel elástico (F) e retire o perno (G) da placa porta-patim direita (P). Remova o patim direito (H) e as 2 placas de bloqueio do patim (L), prestando atenção à mola (N). Desmonte a esfera (M) e a mola (N) do patim direito (H). Recupere todos os componentes.

Remove snap ring (F) and pull out pin (G) from RH footpeg holder plate (P). Remove RH footpeg (H) and no. 2 footpeg stop plates (L), paying attention to spring (N). Remove ball (M) and spring (N) from RH footpeg (H). Keep all components.

Repita a mesma operação para a desmontagem dos patins esquerdos.

Repeat the same procedure to remove LH footpegs.

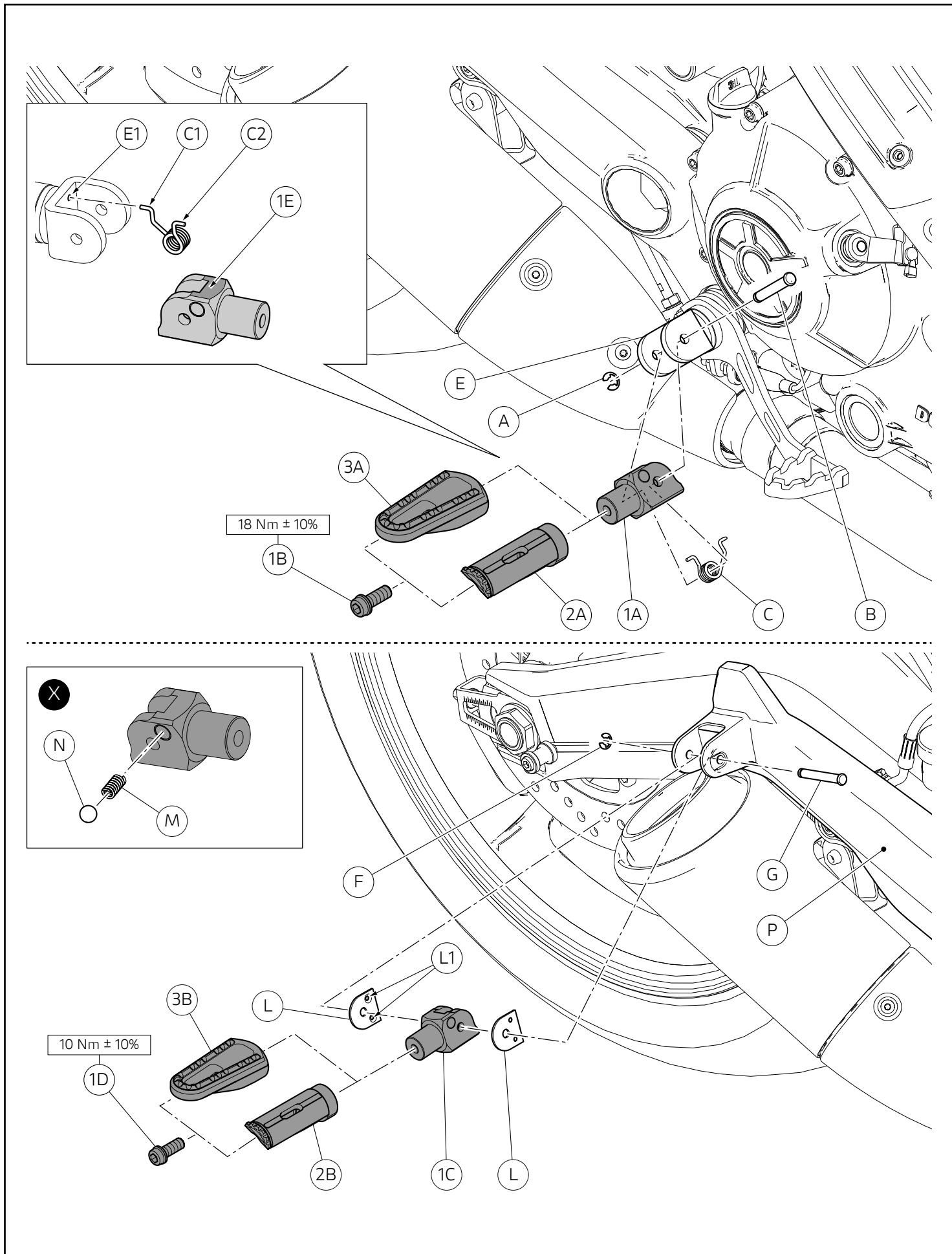

Montagem dos componentes



Importante

Verifique, antes da montagem, se todos os componentes estão limpos e em perfeito estado. Adote todas as precauções necessárias para evitar danificar qualquer peça com a qual deve trabalhar.

Montagem do patim dianteiro direito

Aplique massa Shell Retinax HD2 no perno original (B). Monte a mola original (C) no suporte do patim dianteiro (E), direcionando-a como mostrado na figura, inserindo a extremidade (C1) da mola (C) no furo (E1), como indicado no quadro. Monte a alavanca (1A) no suporte do patim dianteiro (E), posicionando a outra extremidade (C2) da mola (C) na superfície (1E). Insira o perno (B) no suporte do patim dianteiro (E) e bloqueie-o utilizando o anel elástico original (A). Monte o patim (2A) - (3A) na alavanca (1A) e encoste o parafuso (1B). Aperte o parafuso (1B) ao binário indicado. Verifique o correto funcionamento do patim direito dianteiro.

Repita a mesma operação para a montagem do patim dianteiro esquerdo.

Montagem do patim traseiro direito

Aplique massa Shell Retinax HD2 na mola (N). Insira a mola (N) e a esfera (M) no específico furo da alavanca (1C). Posicione as 2 placas de bloqueio do patim (L) na alavanca (1C), direcionando-as como mostrado na figura.



Importante

Coloque as 2 placas de bloqueio do patim (L) com os chanfros dos furos (L1) virados para a alavanca (1C).

Aplique massa Shell Retinax HD2 no perno (G). Introduza a alavanca (1C) no interior da placa porta-patim (E) e fixe-a inserindo o perno (G). Bloqueie o perno (G) utilizando o anel elástico original (F). Monte o patim (2B) (3B) na alavanca (1C) e encoste o parafuso (1D). Aperte o parafuso (1D) ao binário indicado. Verifique o correto funcionamento do patim direito traseiro.

Repita a mesma operação para a montagem do patim traseiro esquerdo.

Kit installation



Caution

Check that all components are clean and in perfect condition before installation. Adopt any precaution necessary to avoid damages to any part of the motorcycle you are working on.

Front RH footpeg assembly

Apply Shell Retinax HD2 grease on original pin (B). Fit original spring (C) on front footpeg support (E), aiming it as shown in the figure, by inserting end (C1) of the spring (C) in hole (E1) as shown in the box. Fit lever (1A) on front footpeg support (E), positioning the other end (C2) of spring (C) on surface (1E). Fit pin (B) on front footpeg support (E) and lock it with the original snap ring (A). Fit footpeg (2A) - (3A) on lever (1A) and start screw (1B). Tighten screw (1B) to the specified torque. Make sure that front RH footpeg works properly.

Repeat the same procedure for front LH footpeg assembly.

Rear RH footpeg assembly

Apply Shell Retinax HD2 grease on spring (N). Fit spring (N) and ball (M) into the relevant hole of lever (1C). Place no. 2 footpeg stop plates (L) on lever (1C), aiming them as shown in the figure.



Caution

Position no. 2 footpeg stop plates (L) with hole countersinks (L1) facing lever (1C).

Apply Shell Retinax HD2 grease on pin (G). Fit lever (1C) inside footpeg holder plate (E) and fasten it by fitting pin (G). Lock pin (G) with original snap ring (F). Fit footpeg (2B) - (3B) on lever (1C) and start screw (1D). Tighten screw (1D) to the specified torque. Make sure that rear RH footpeg works properly.

Repeat the same procedure for rear LH footpeg assembly.

Kit adaptadores estribos / フットペグアダプターキット - 96280511A
 Kit estribos Pro - 96280501AA (Negro) - 96280501AB (Plata)
 Pro フットペグキット - 96280501AA (ブラック) - 96280501AB (シルバー)
 Kit estribos apoya pies de aluminio / アルミニウム製フットレストキット - 96280561AA

Símbolos

Para una lectura rápida y racional se han empleado símbolos que evidencian situaciones de máxima atención, consejos prácticos o simples informaciones. Prestar mucha atención al significado de los símbolos porque su función consiste en omitir la repetición de conceptos técnicos o advertencias de seguridad. Los símbolos deben considerarse como verdaderos "apuntes". Consultar esta página cada vez que se tengan dudas sobre su significado.



Atención

El incumplimiento de las instrucciones indicadas puede crear una situación de peligro y ocasionar graves lesiones e incluso la muerte.



Importante

Indica la posibilidad de provocar un daño al vehículo y/o a sus componentes si no se siguen las instrucciones indicadas.



Notas

Suministra útiles informaciones sobre la operación en curso.

Referencias

Las partes resaltadas en gris y la referencia numérica (Por ej. ①) representan el accesorio que se debe instalar y los eventuales componentes de montaje suministrados en el kit.

Las partes con referencia alfabética (Por ej. (A)) representan los componentes originales presentes en la motocicleta.

Todas las indicaciones derecha o izquierda se refieren al sentido de marcha de la motocicleta.

Advertencias generales



Atención

Las operaciones descritas en las siguientes páginas deben realizarse correctamente para no perjudicar la seguridad del piloto.



Atención

Las operaciones descritas en las siguientes páginas deben realizarse correctamente para no perjudicar la seguridad del piloto.



Notas

La documentación necesaria para realizar el montaje del Kit es el: Manual De Taller, relativo al modelo de moto en vuestro poder.



Notas

Si fuera necesario sustituir un componente del kit, consultar la tabla de recambios adjunta.

シンボル

素早くかつ合理的に読み進めることができるように、本マニュアルではいくつかのシンボルを導入し、最大限の注意を払う必要がある状況や、推奨事項、または一般情報を明確にしてあります。技術的概念や安全に関する警告を繰り返し記載する必要がないように機能しているので、各シンボルの意味に十分注意してください。シンボルは、実際上の“覚え書き”であると考えてください。シンボルなどの意味がわからなくなったり疑問に思う場合は、必ずこのページで調べるようにしてください。



注記

この説明書に従わずに使用すると危険な状況を招き、重大なけが、あるいは死をももたらす原因となることがあります。



重要

この説明書に従わずに使用すると、車体及び/又はその部品に損害を招く可能性があります



参考

操作中の内容に関する有用な情報を掲載しています。

参照

灰色で表示する部品、および参照番号 (Es.①) で表示する部品は、キットに付属する取り付け部品および組み立て部品を示します。

参照アルファベット (Es.(A)) で表示する部品は、車両に付属するオリジナル部品を示します。

すべての右及び左の指示は車体の進行方向を向いたものです。

一般警告事項



注記

以下のページに記載されている作業が規定通りに実施されないと、ライダーの安全性を脅かすおそれがあります。



注記

以下のページに記載されている作業が規定通りに実施されないと、ライダーの安全性を脅かすおそれがあります。



参考

キットの取り付けに必要な資料：お手持ちの車両モデルに対応するワークショップマニュアル。



参考

キットの部品を交換する必要がある場合は、添付のスペアパーツ表を参照してください。

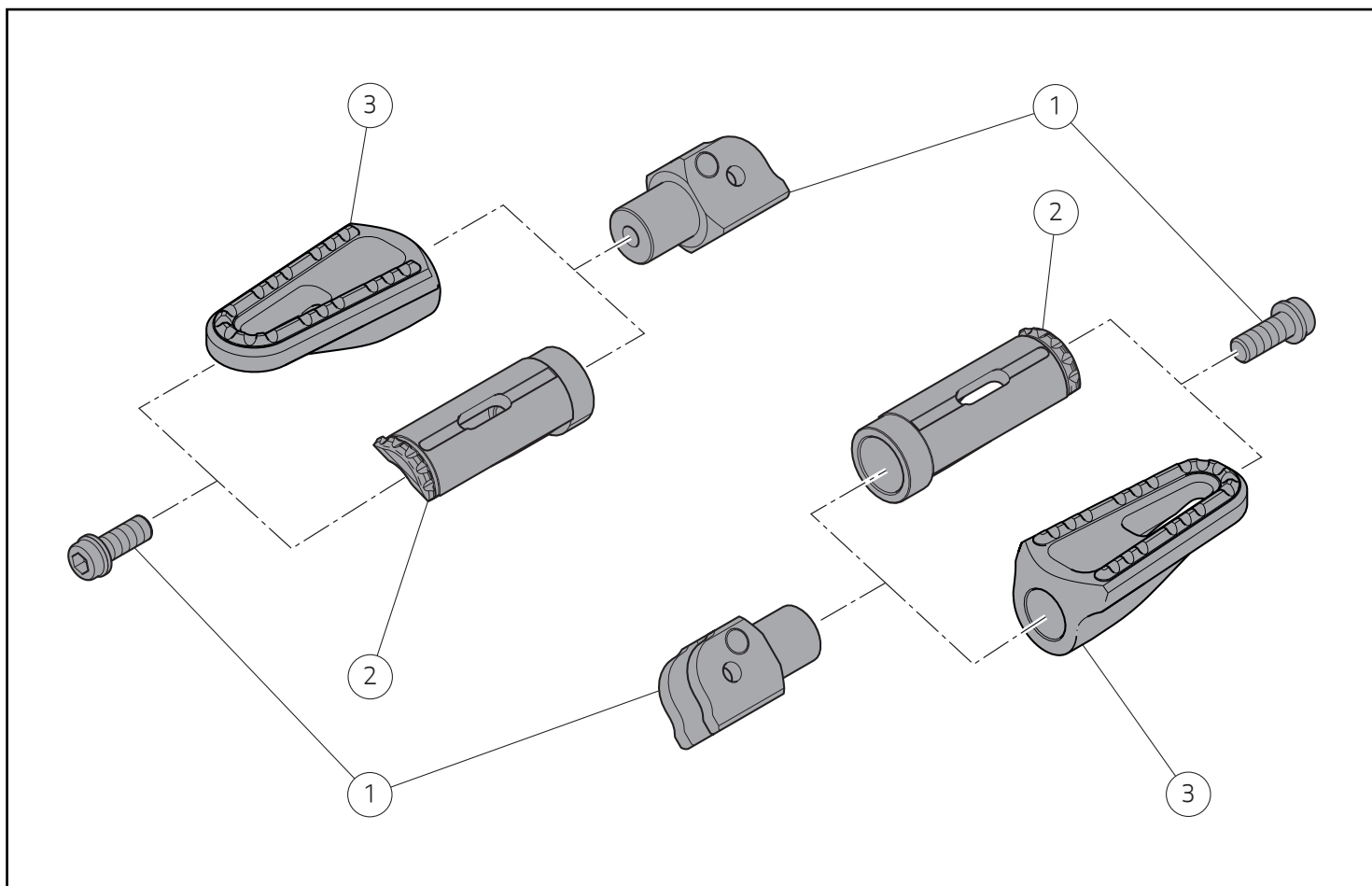

Pos.	Denominacion	説明
1	Kit adaptadores estribos	フットペグアダプターキット
2	Kit estribos Pro (Hypermotard - Supersport - Monster - Multistrada - Superbike)	Pro フットペグキット (Hypermotard - Supersport - Monster - Multistrada - Superbike)
3	Kit estribos apoya pies de aluminio (Scrambler)	アルミニウム製フットレストキット (Scrambler)

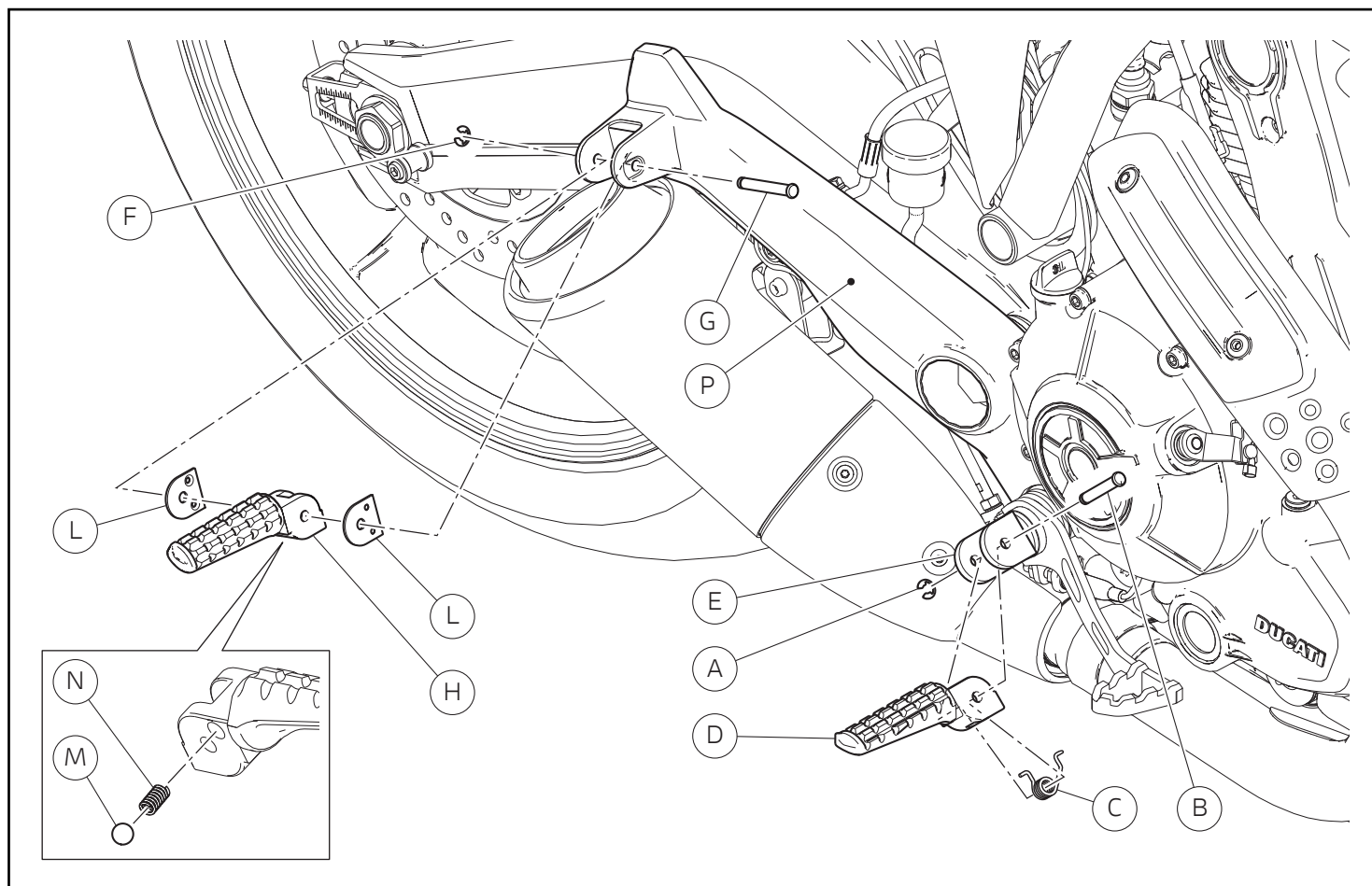

Desmontaje protector cárter

Desmontaje estribos derechos

Operando en el lado derecho de la motocicleta, desmontar el anillo de seguridad (A) y extraer el perno (B). Quitar el estribo derecho (D) y el muelle (C) del soporte estribo delantero (E). Recuperar el anillo de seguridad (A), el perno (B) y el muelle (C).

Desmontar el anillo elástico (F) y extraer el perno (G) de la placa porta estribo derecha (P). Quitar el estribo derecho (H) y las 2 plaquetas parada estribo (L), prestando atención al muelle (N). Desmontar la esfera (M) y el muelle (N) del estribo derecho (H). Recuperar todos los componentes.

Repetir esta misma operación para el desmontaje de los estribos izquierdos.

オリジナル部品の取り外し

右フットペグの取り外し

車両の右側で作業します。安全リング (A) を取り外し、ピン (B) を引き抜きます。右フットペグ (D) とスプリング (C) をフロントフットペグマウント (E) から取り外します。安全リング (A)、ピン (B)、スプリング (C) を回収します。

サークリップ (F) を取り外し、ピン (G) を右フットペグホルダープレート (P) から引き抜きます。スプリング (N) に注意しながら、右フットペグ (H) と 2 枚のペダル固定プレート (L) を取り外します。ボール (M) とスプリング (N) を右フットペグ (H) から取り外します。すべての部品を回収します。

左フットペグの取り外しについても同様の操作を繰り返します。

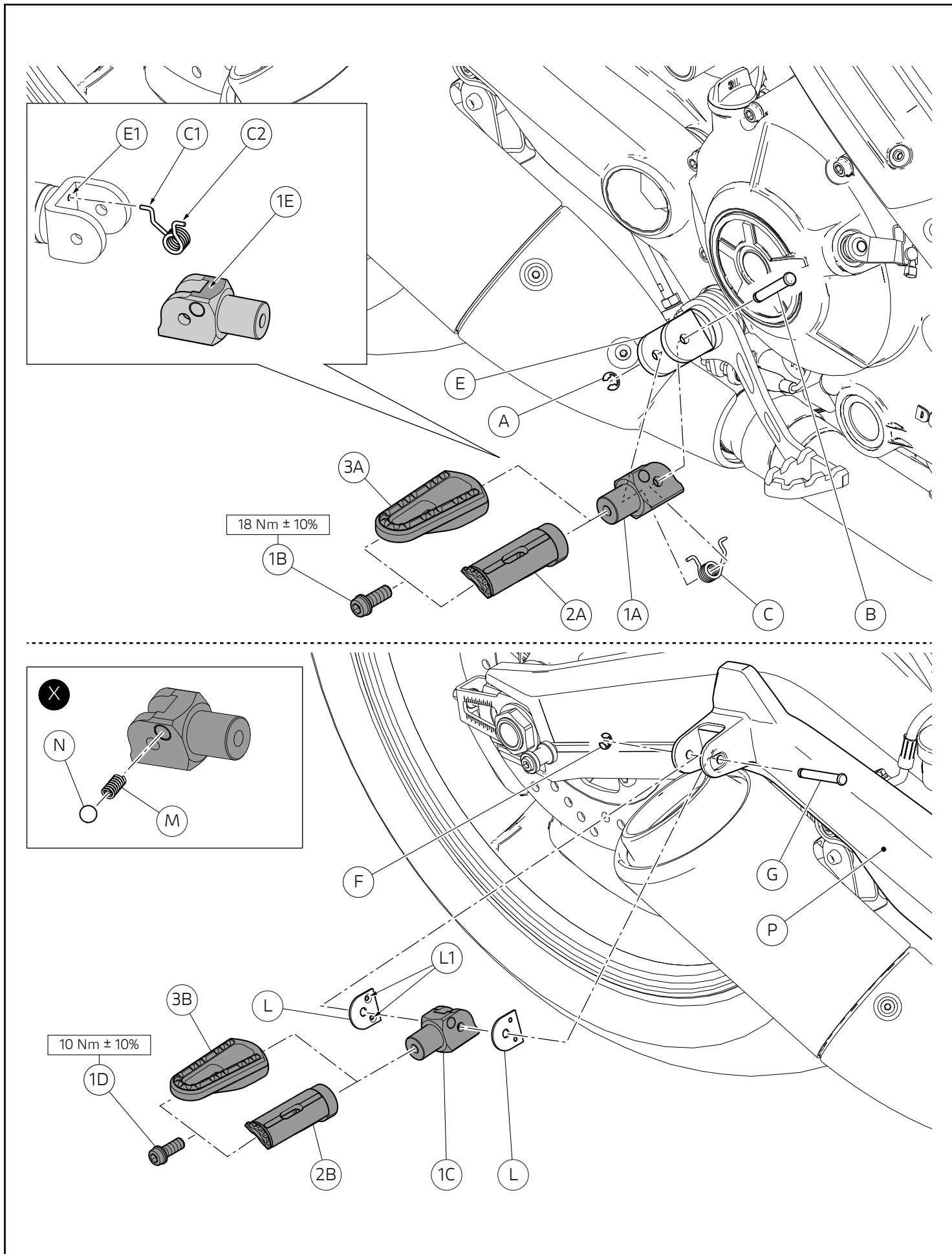

Montaje componentes kit

● Importante

Controlar, antes del montaje, que todos los componentes se encuentren limpios y en perfecto estado. Adoptar todas las precauciones necesarias para evitar daños en la superficie exterior de los componentes donde se debe operar.

Montaje estribo delantero derecho

Aplicar grasa Shell Retinax HD2 en el perno original (B). Montar el muelle original (C) en el soporte estribo delantero (E), orientándolo como ilustra la figura e introduciendo el extremo (C1) del muelle (C) en el orificio (E1), como muestra el recuadro. Montar la leva (1A) en el soporte estribo delantero (E), colocando el otro extremo (C2) del muelle (C) en la superficie (1E). Introducir el perno (B) en el soporte estribo delantero (E), y bloquearlo usando el anillo elástico original (A). Montar el estribo (2A) - (3A) en la leva (1A) e introducir el tornillo (1B). Ajustar el tornillo (1B) al par de apriete indicado. Comprobar el funcionamiento correcto del estribo derecho delantero.

Repetir esta misma operación para el montaje del estribo delantero izquierdo.

Montaje estribo trasero derecho

Aplicar grasa Shell Retinax HD2 en el muelle (N). Introducir el muelle (N) y la esfera (M) en el específico orificio de la leva (1C). Colocar las 2 plaquetas parada estribo (L) en la leva (1C), orientándolas como ilustra la figura.

● Importante

Orientar las 2 plaquetas parada estribo (L) con la concavidad de los orificios (L1) hacia la leva (1C).

Aplicar grasa Shell Retinax HD2 en el perno (G). Introducir la leva (1C) en la placa porta estribo (E) y fijarla introduciendo el perno (G). Bloquear el perno (G) utilizando el anillo elástico original (F). Montar el estribo (2B) - (3B) en la leva (1C) e introducir el tornillo (1D). Ajustar el tornillo (1D) al par de apriete indicado. Comprobar el correcto funcionamiento del estribo derecho trasero.

Repetir esta misma operación para el montaje del estribo trasero izquierdo.

キット部品の取り付け

● 重要

取り付け前にすべての部品に汚れがなく、完璧な状態であることを確認します。作業する部品の外側表面を傷つけないために、必要な予防措置を取ってください。

右フロントフットペグの取り付け

グリース Shell Retinax HD2 をオリジナルのピン (B) に塗布します。オリジナルのスプリング (C) を図のように向けてフロントフットペグマウント (E) に取り付けます。このとき、スプリング (C) の先端 (C1) を枠内に示すように穴 (E1) に差し込みます。レバー (1A) をフロントフットペグマウント (E) に取り付けます。このときスプリング (C) のもう一方の先端 (C2) を表面 (1E) に配置します。ピン (B) をフロントフットペグマウント (E) に挿入し、オリジナルのサークリップ (A) で固定します。フットペグ (2A) をレバー (1A) に取り付け、スクリュー (1B) を差し込みます。スクリュー (1B) を規定のトルクで締め付けます。右フロントフットペグが正常に機能することを確認してください。

左フロントフットペグの取り付けについても同様の操作を繰り返します。

右リアフットペグの取り付け

グリース Shell Retinax HD2 をスプリング (N) に塗布します。レバー (1C) の所定の穴にスプリング (N) とボール (M) を挿入します。レバー (1C) に 2 枚のフットペグ固定プレート (L) を図のように向けて配置します。

● 重要

2 枚のフットペグ固定プレート (L) の穴 (L1) の広がっている方をレバー (1C) に向けて取り付けます。

グリース Shell Retinax HD2 をピン (G) に塗布します。レバー (1C) をフットペグホルダープレート (E) の内部に取り付け、ピン (G) を挿入して固定します。オリジナルのサークリップ (F) を使用してピン (G) を固定します。フットペグ (2B) をレバー (1C) に取り付け、スクリュー (1D) を差し込みます。スクリュー (1D) を規定のトルクで締め付けます。右リアフットペグが正常に機能することを確認してください。

左リアフットペグの取り付けについても同様の操作を繰り返します。

レース専用部品 ご注文書

ご注文商品

1	P/N	商品名
2	P/N	商品名
3	P/N	商品名
4	P/N	商品名
5	P/N	商品名

お客様ご記入欄

私は上記レース専用部品を下記車両に装着し、サーキット走行のみに利用し、一般公道には利用しません。

車台番号 ZDM モデル名

お客様署名 ご注文日

ドウカティ正規ネットワーク店記入欄

お客様に上記レース専用部品を販売し、レース専用部品のご利用方法を説明いたしました。

販売店署名 販売日 年 月 日

販売店様へお願い

- 上記ご記入の上、弊社アフターセールス部までFAXしてください。FAX : 03 - 6692 - 1317
- 取り付け車両 1台に 1枚でご使用ください。