

Kit montaggio antifurto - 96680531B

Anti-theft system installation set - 96680531B

Simbologia

Per una lettura rapida e razionale sono stati impiegati simboli che evidenziano situazioni di massima attenzione, consigli pratici o semplici informazioni. Prestare molta attenzione al significato dei simboli, in quanto la loro funzione è quella di non dovere ripetere concetti tecnici o avvertenze di sicurezza. Sono da considerare, quindi, dei veri e propri "promemoria". Consultare questa pagina ogni volta che sorgessero dubbi sul loro significato.

**Attenzione**

La non osservanza delle istruzioni riportate può creare una situazione di pericolo e causare gravi lesioni personali e anche la morte.

**Importante**

Indica la possibilità di arrecare danno al veicolo e/o ai suoi componenti se le istruzioni riportate non vengono eseguite.

**Note**

Fornisce utili informazioni sull'operazione in corso.

Riferimenti

I particolari evidenziati in grigio e riferimento numerico (Es. ①) rappresentano l'accessorio da installare e gli eventuali componenti di montaggio forniti a kit.

I particolari con riferimento alfabetico (Es. Ⓐ) rappresentano i componenti originali presenti sul motoveicolo.

Tutte le indicazioni destro o sinistro si riferiscono al senso di marcia del motociclo.

Avvertenze generali

**Attenzione**

Le operazioni riportate nelle pagine seguenti devono essere eseguite da un tecnico specializzato o da un'officina autorizzata Ducati.

**Attenzione**

Le operazioni riportate nelle pagine seguenti se non eseguite a regola d'arte possono pregiudicare la sicurezza del pilota.

**Note**

Documentazione necessaria per eseguire il montaggio del Kit è il Manuale Officina, relativo al modello di moto in vostro possesso.

**Note**

Nel caso fosse necessaria la sostituzione di un componente del kit consultare la tavola ricambi allegata.

Symbols

To allow quick and easy consultation, this manual uses graphic symbols to highlight situations in which maximum care is required, as well as practical advice or information. Pay attention to the meaning of the symbols since they serve to avoid repeating technical concepts or safety warnings throughout the text. The symbols should therefore be seen as real reminders. Please refer to this page whenever in doubt as to their meaning.

**Warning**

Failure to follow these instructions might give rise to a dangerous situation and provoke severe personal injuries or even death.

**Caution**

Failure to follow these instructions might cause damages to the vehicle and/or its components.

**Notes**

Useful information on the procedure being described.

References

Parts highlighted in grey and with a numeric reference (Example ①) are the accessory to be installed and any assembly components supplied with the kit.

Parts with an alphabetic reference (Example Ⓐ) are the original components fitted on the vehicle.

Any right- or left-hand indication refers to the vehicle direction of travel.

General notes

**Warning**

Carefully perform the operations on the following pages since they might negatively affect rider safety.

**Warning**

Carefully perform the operations on the following pages since they might negatively affect rider safety.

**Notes**

The following documents are necessary for assembling the Kit: Workshop Manual of your bike model.

**Notes**

Should it be necessary to change any kit parts, please refer to the attached spare part table.

**Warning**

Operating, servicing and maintaining a passenger vehicle or off-highway motor vehicle can expose you to chemicals including engine exhaust, carbon monoxide, phthalates, and lead, which are known to the State of California to cause cancer and birth defects or other reproductive harm. To minimize exposure, avoid breathing exhaust, do not idle the engine except as necessary, service your vehicle in a well-ventilated area and wear gloves or wash your hands frequently when servicing your vehicle. For more information go to www.P65Warnings.ca.gov/passenger-vehicle.

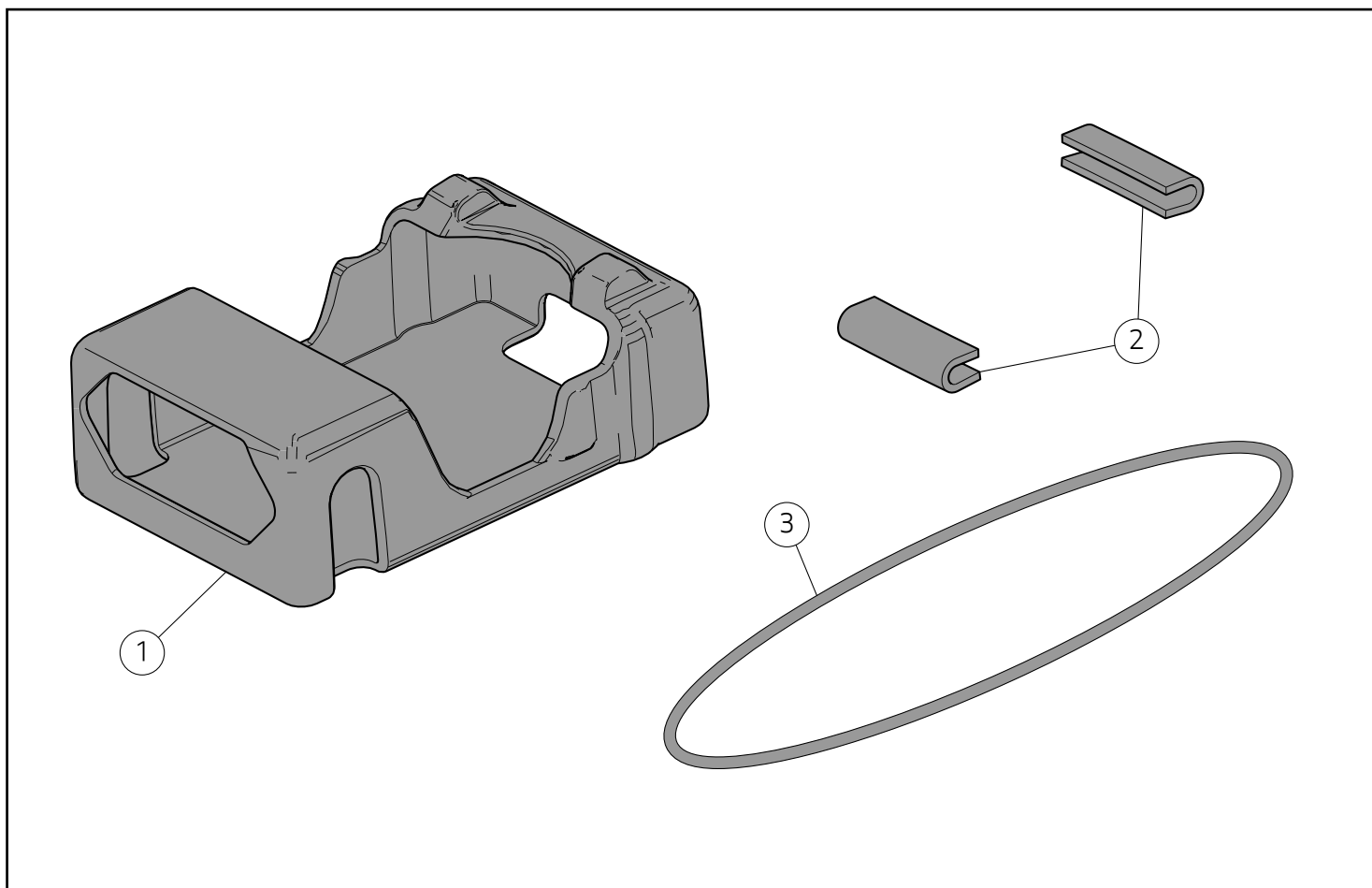

● Importante

I componenti del kit possono essere soggetti ad aggiornamenti; consultare il DCS (Dealer Communication System) per avere informazioni sempre aggiornate.

● Importante

Il presente set montaggio antifurto, deve essere abbinato al set antifurto, composto da centralina e telecomandi, adeguato al modello di motoveicolo in possesso.

👁 Note

Ogni modello di motoveicolo, ha un differente metodo di fissaggio della centralina. Il kit viene fornito completo di tutti i diversi tipi di fissaggio. Seguire scrupolosamente il metodo di fissaggio indicato per ogni singolo modello.

● Important

Kit components may be subject to upgrades; refer to the DCS (Dealer Communication System) for updated information.

● Important

This anti-theft system assembly kit must be combined with the anti-theft system set, consisting of control unit and remote controls, suitable for the concerned bike.

👁 Notes

Each bike model has a different method for control unit fastening. The kit is supplied with all the types of fasteners. Thoroughly follow the fastening method specified for each single model.

Pos.	Denominazione	Description
1	Supporto antivibrante	Vibration damping support
2	Gommino	Grommet
3	OR per fissaggio	Fixing O-RING

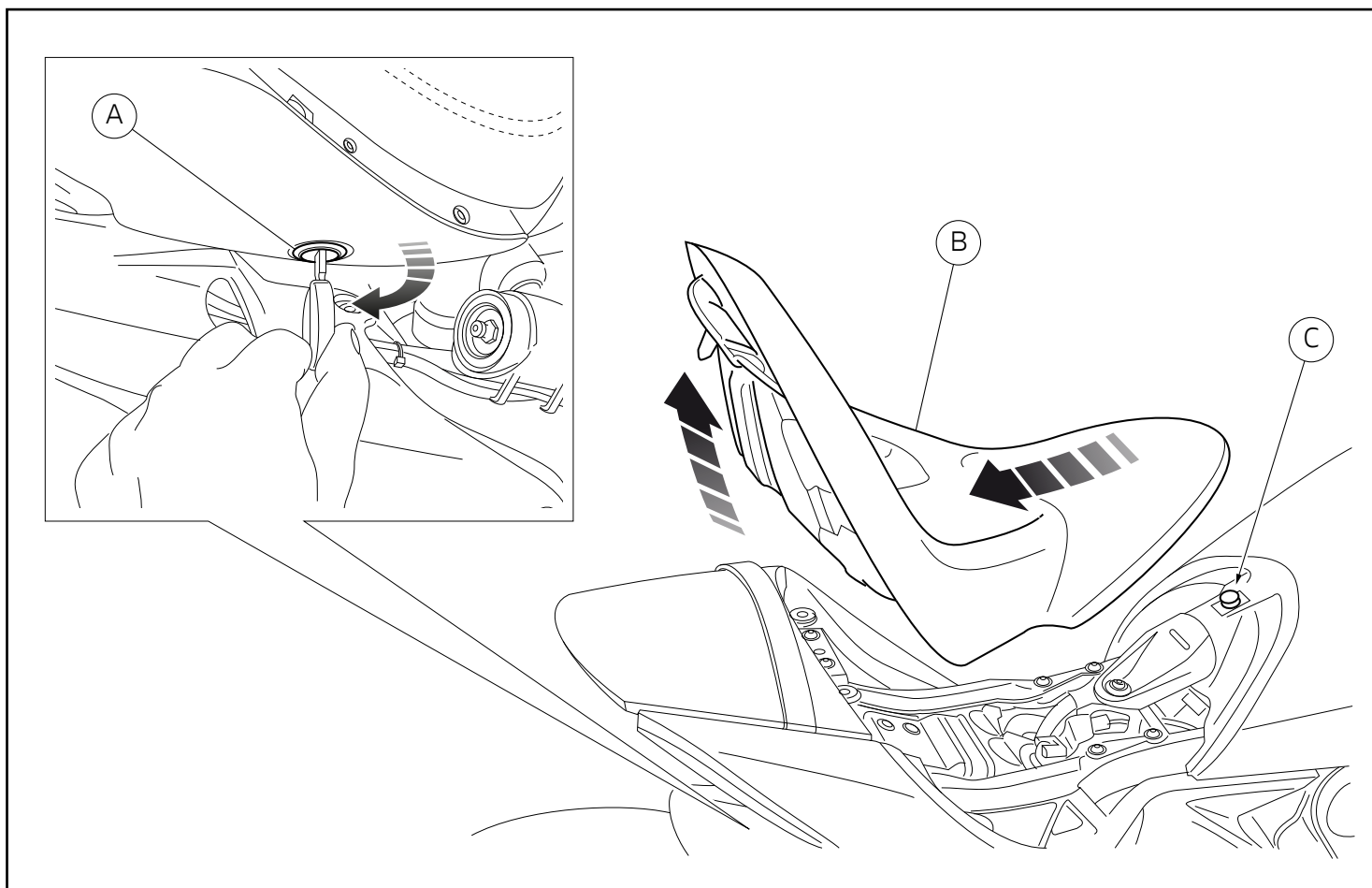

Smontaggio componenti originali (versioni XDiavel)

Smontaggio sella conducente

Introdurre la chiave nella serratura (A) e ruotarla in senso orario fino a sentire lo scatto di sgancio della sella conducente (B). Sfilare la sella (B) dal perno del serbatoio (C), tirandola all'indietro e contemporaneamente verso l'alto.

Removing the original components (XDiavel versions)

Removing the rider seat

Insert the key into the lock (A) and turn it clockwise until the rider seat catch (B) disengages with an audible click. Remove seat (B) from tank pin (C), by pulling it backwards and upwards at the same time.

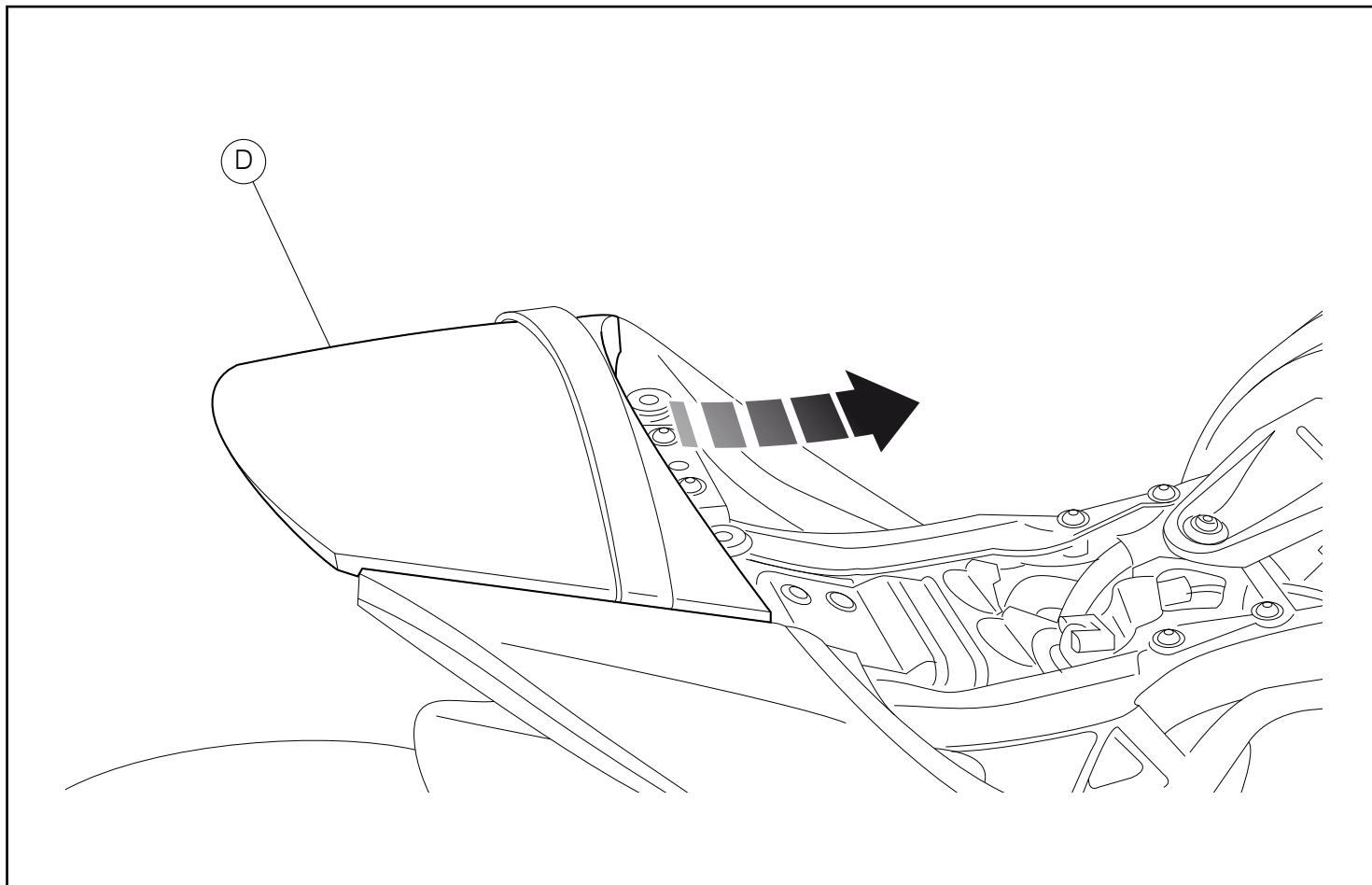

Smontaggio sella passeggero

Rimuovere la sella passeggero (D) sfilandola verso l'anteriore del motoveicolo.

Removing the passenger seat

Remove passenger seat (D) sliding it towards the motorcycle front side.

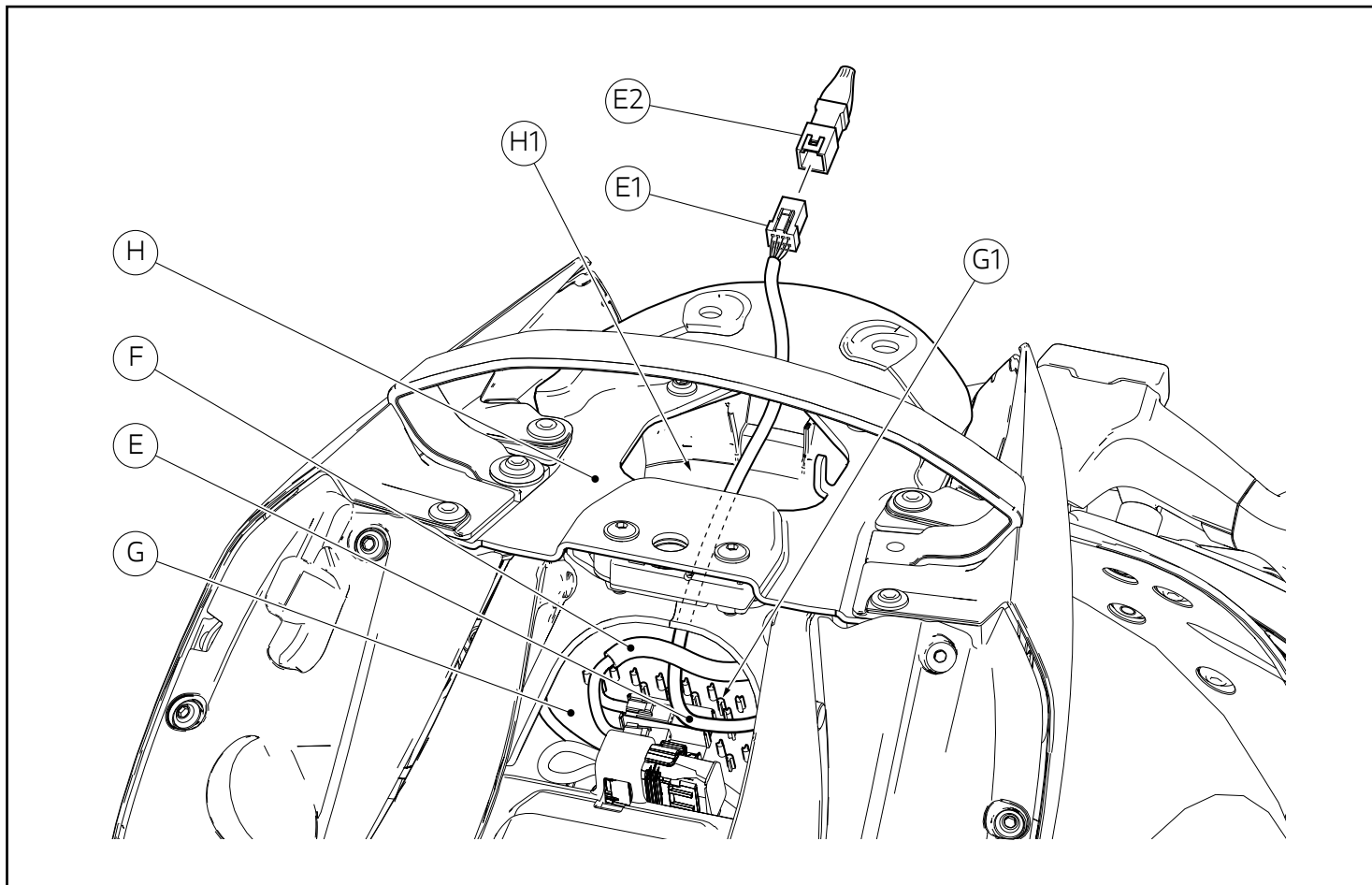

Posizionamento cablaggio

Estrarre il cavo cablaggio fari posteriori (F) dai pioli (G1) presenti sul coperchio inferiore codone (G). Introdurre il cavo cablaggio centralina (E) attraverso il vano interno (H1) della vaschetta portaoggetti (H), facendo in modo che risulti al di sotto del cavo cablaggio fari posteriori (F), come mostrato in figura. Rimuovere il tappo (E2) dal connettore (E1).

Wiring positioning

Remove tail lights wiring cable (F) from pins (G1) on tail guard lower cover (G). Insert control unit wiring cable (E) through inner compartment (H1) of glove compartment (H), so that it is under tail lights wiring cable (F), as shown in the figure. Remove plug (E2) from connector (E1).

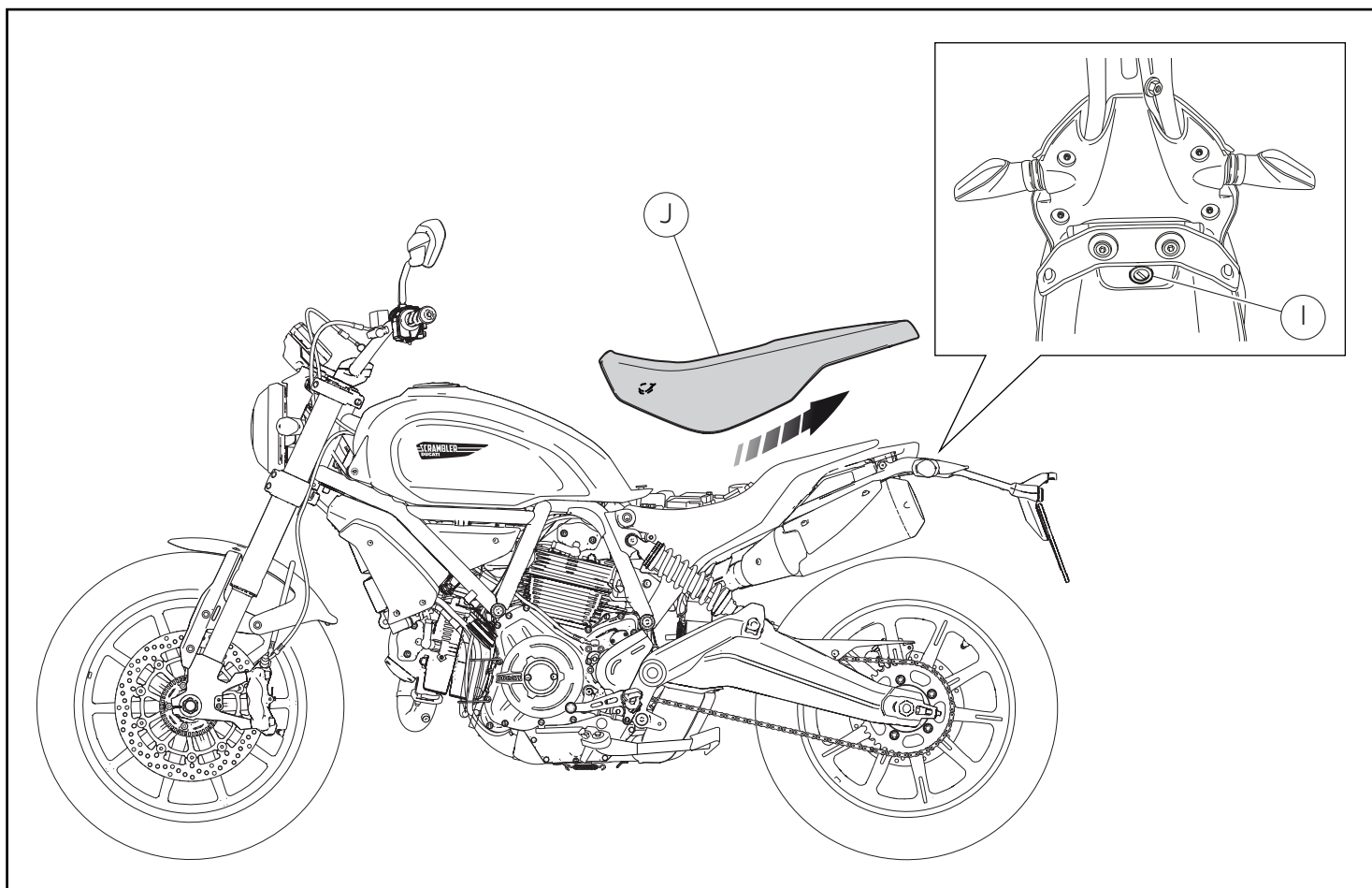

Smontaggio componenti originali (versioni Scrambler 1100)

Smontaggio sella conducente

Introdurre la chiave nella serratura (I) e ruotarla in senso orario fino a sentire lo scatto di sgancio della sella conducente (J). Sfilare la sella (J) dai fermi anteriori, tirandola all'indietro.

Removing the original components (Scrambler 1100 versions)

Removing the rider seat

Insert the key into the lock (I) and turn it clockwise until the rider seat catch (J) disengages with an audible click. Pull the seat (J) backwards to release it from the front catches.

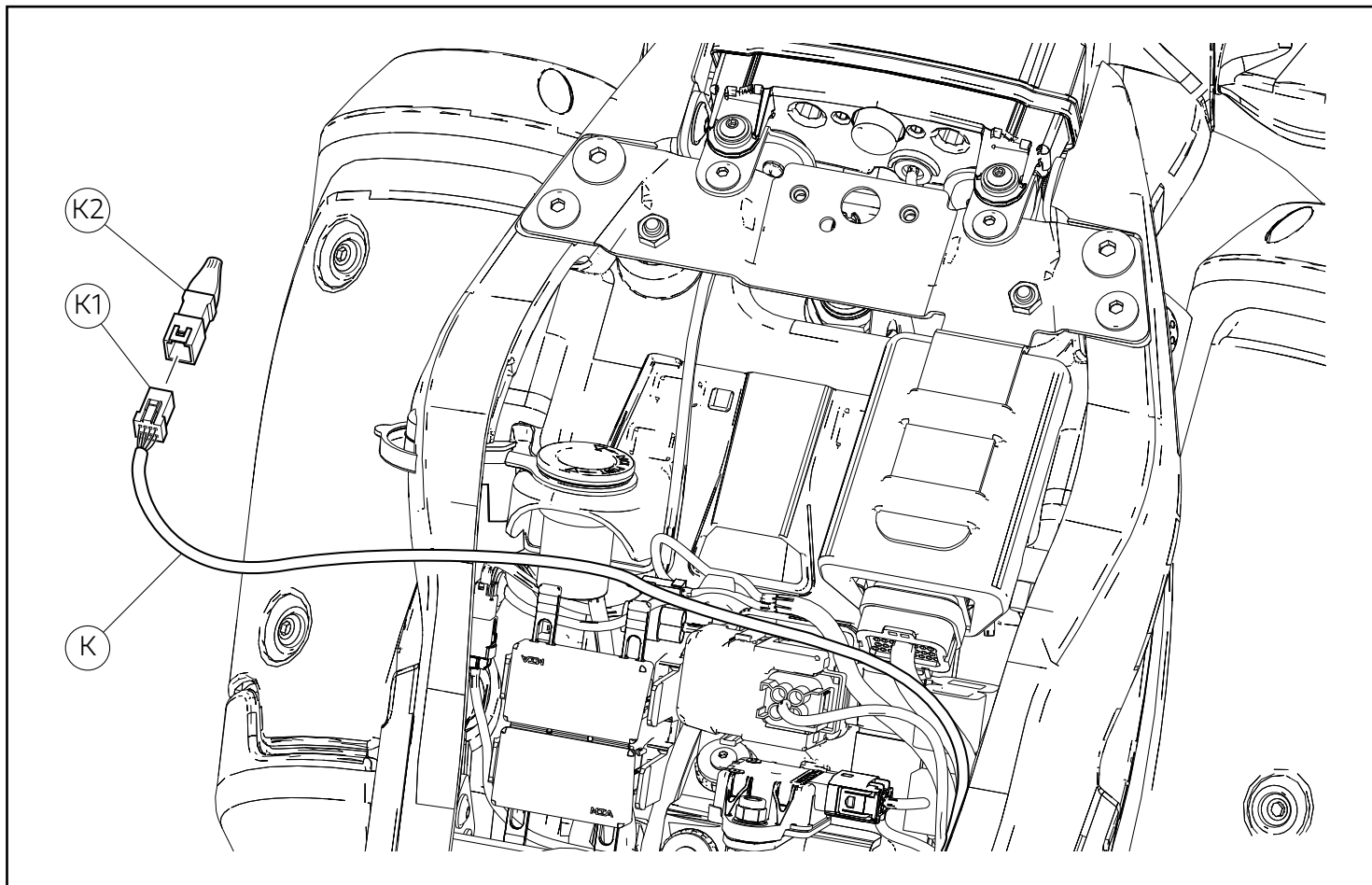

Posizionamento cablaggio

Rimuovere il tappo (K2) dal connettore (K1) del cablaggio centralina (K).



Note

La lunghezza dei cablaggi rappresentati in figura è da ritenersi puramente indicativa.

Wiring positioning

Remove the plug (K2) from control unit (K) wiring connector (K1).



Notes

The length of the wirings shown in the figure is to be considered purely indicative

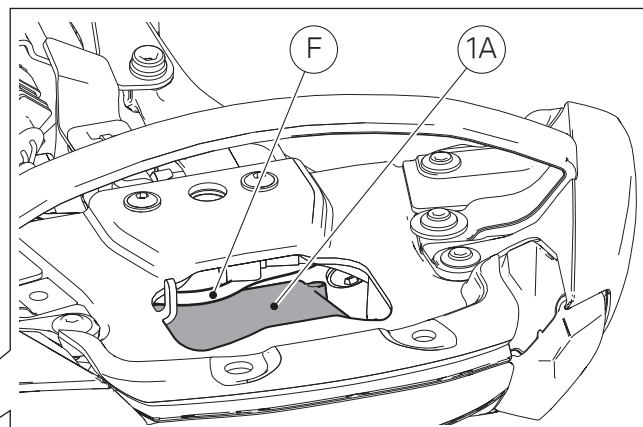
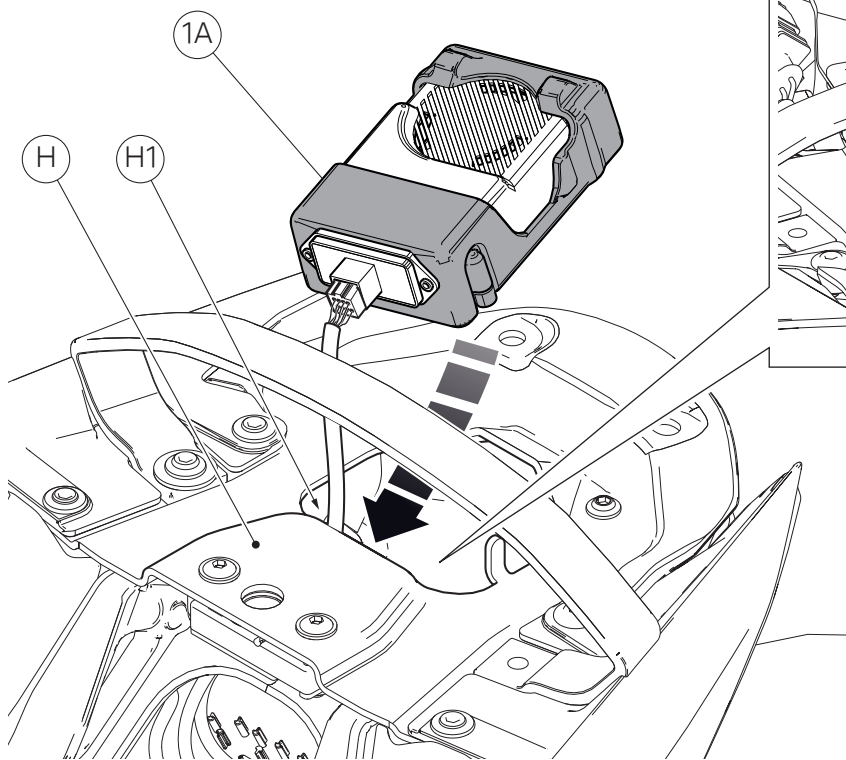
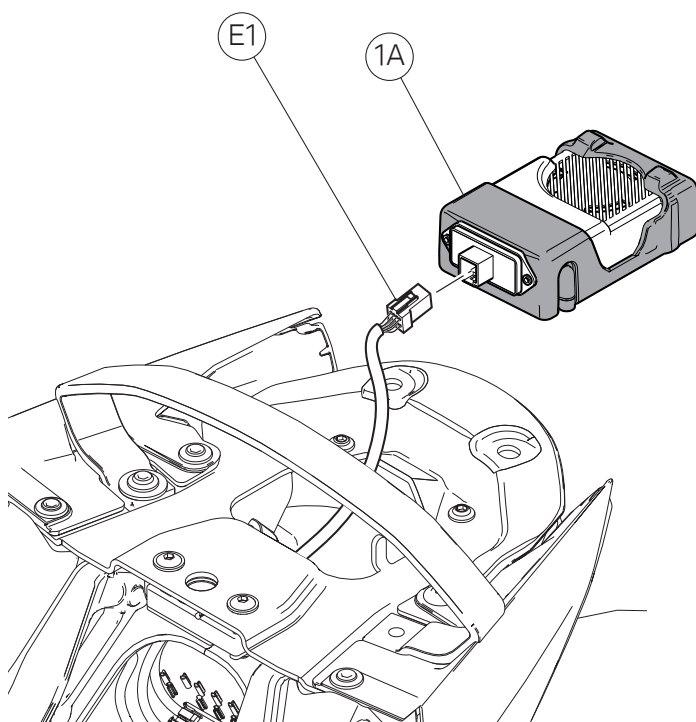
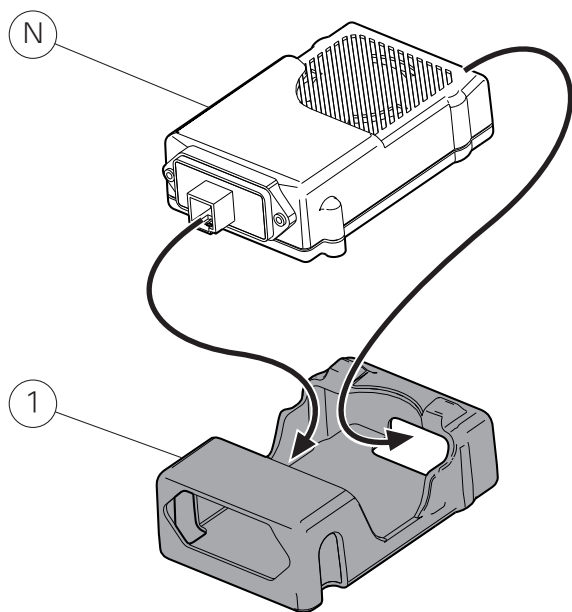

Montaggio componenti kit (versioni XDiavel)



Importante

Verificare, prima del montaggio, che tutti i componenti risultino puliti e in perfetto stato. Adottare tutte le precauzioni necessarie per evitare di danneggiare qualsiasi parte nella quale ci si trova ad operare.

Montaggio centralina

Inserire la centralina (N) nel supporto antivibrante (1) calzandola prima dal lato dotato di connessione, poi dall'altro. Collegare il connettore (E1) al gruppo centralina (N). Introdurre il gruppo centralina (1A) all'interno del vano (H1) della vaschetta portaoggetti (H).



Importante

Il cavo cablaggio fari posteriori (F) deve essere posizionato al di sopra del gruppo centralina (1A) come mostrato in figura.

Assembling the kit components (XDiavel versions)



Important

Before assembly, make sure that all parts are clean and in perfect conditions. Take all the necessary measures to avoid damaging any part you are working on.

Fitting the control unit

Insert control unit (N) inside vibration damping support (1) by fitting it first on the side featuring the connection and then on the other side. Connect connector (E1) to control unit assembly (N). Insert control unit assembly (1A) inside compartment (H1) of glove compartment (H).



Important

Tail lights wiring cable (F) must be positioned above control unit assembly (1A), as shown in the figure.

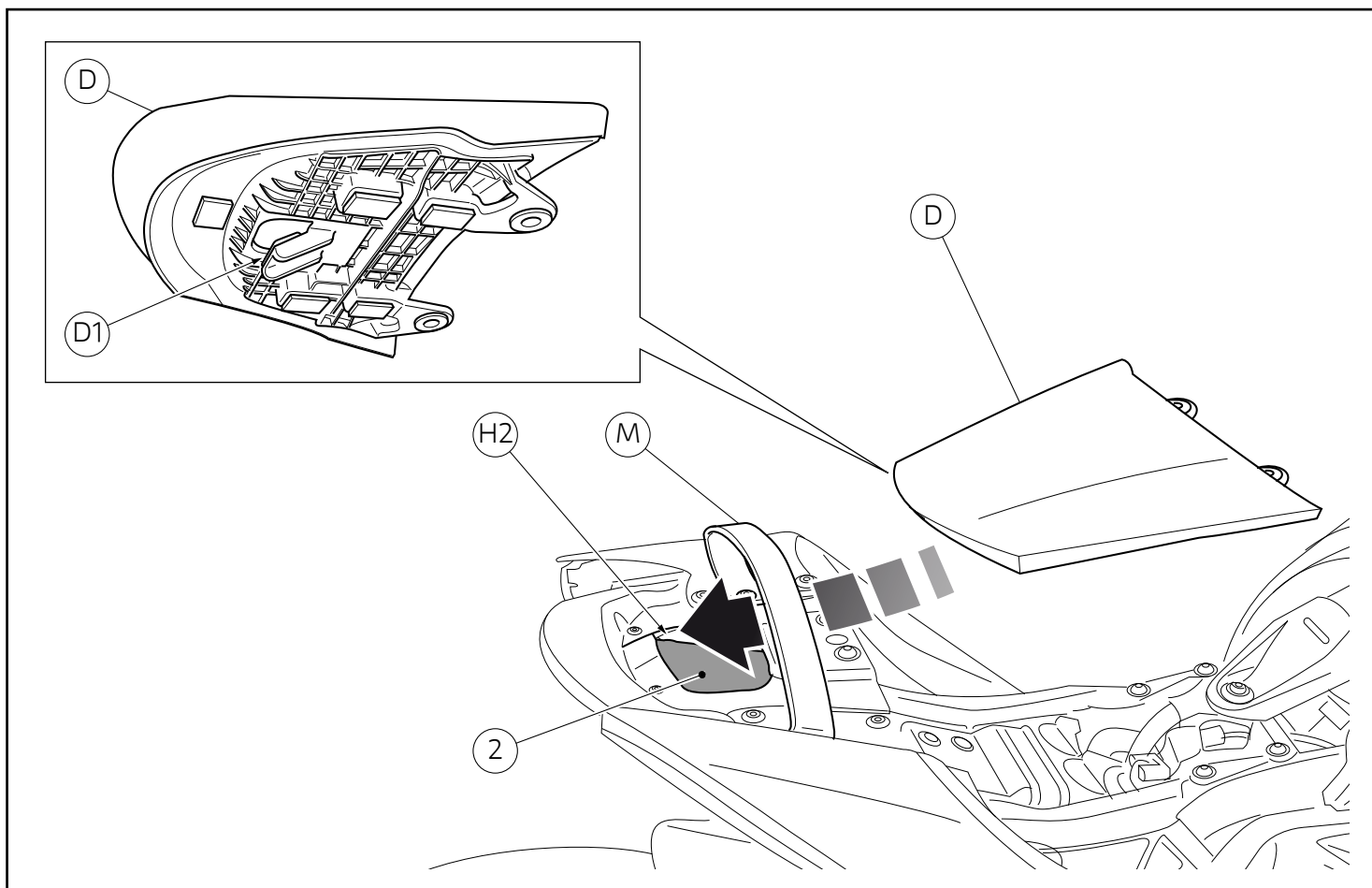

Note

Prima di rimontare la sella occorre eseguire la procedura di attivazione antifurto. Vedi "Attivazione/Disattivazione antifurto".

Rimontaggio sella passeggero

Montare la sella passeggero (D) posizionandola sotto la cinghia (M), facendola scorrere verso il posteriore del motoveicolo, inserire la linguetta (D1) nell'apposita sede (H2).



Importante

Controllare che il gruppo centralina antifurto (1) sia disposto nel vano portaoggetti in modo tale che non resti schiacciato dalla sella passeggero (D).



Notes

Before refitting seat, carry out the anti-theft system activation procedure. See "Activating/deactivating anti-theft system".

Passenger seat reassembly

Install passenger seat (D) fitting it under strap (M), sliding it towards the motorcycle rear side, insert tab (D1) in its housing (H2).



Important

Check that anti-theft system control unit (2) is positioned in the glove compartment so that it is not squeezed by passenger seat (D).

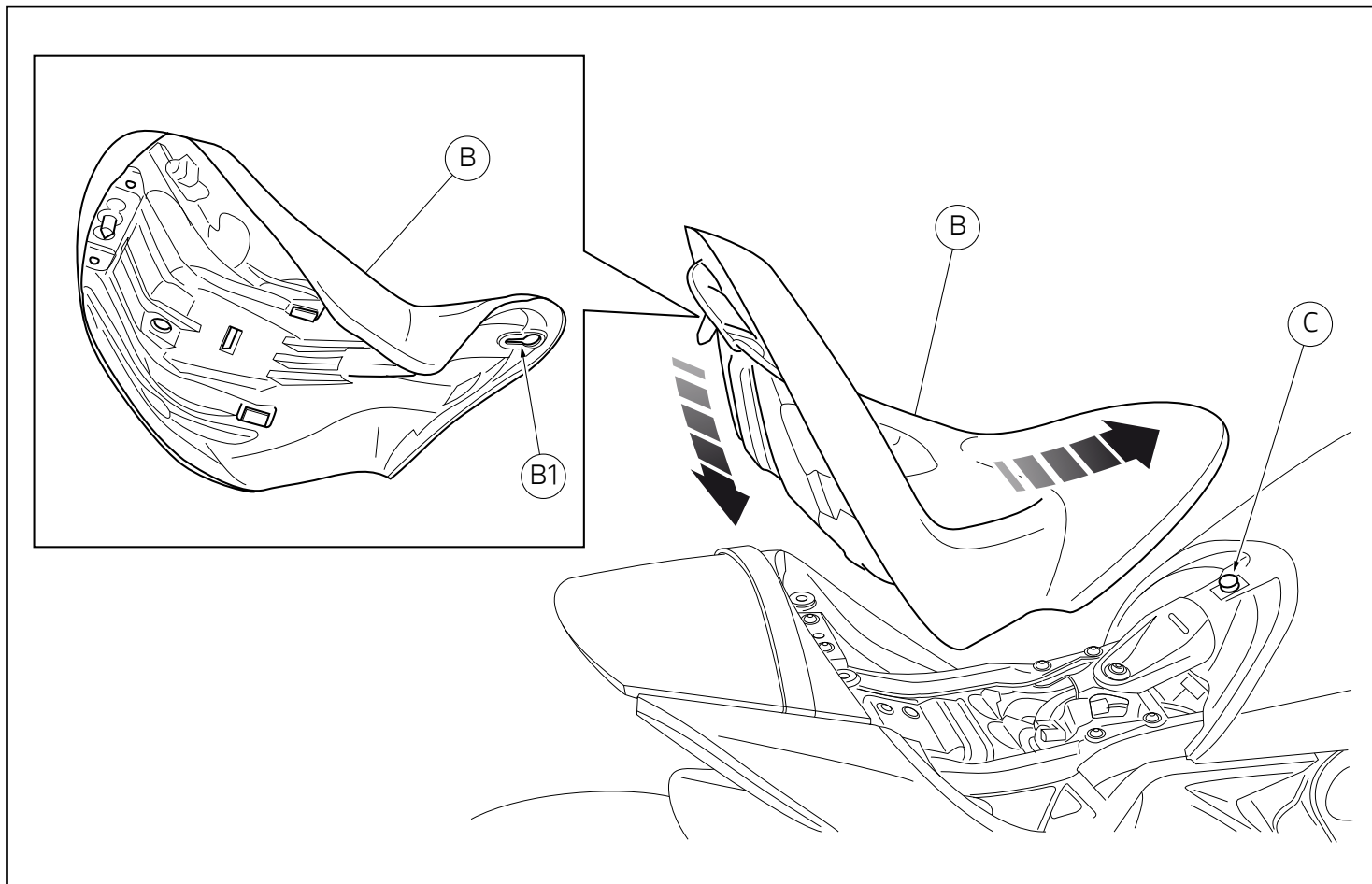

Rimontaggio sella conducente

Posizionare la sella conducente (B), introducendo il perno del serbatoio (C) nell'asola (B1) della sella. Traslare verso l'anteriore del motoveicolo la sella (B) sino a fine corsa. Premere l'estremità posteriore della sella (B) fino ad udire lo scatto del chiavistello della serratura. Accertarsi dell'avvenuto e corretto aggancio, tirando con moderazione verso l'alto la sella conducente. Sfilare la chiave dalla serratura.

Rider seat reassembly

Position rider seat (B) fitting tank pin (C) in slot (B1) of the seat. Move seat (B) towards the front side of the motorcycle until it stops. Press seat (B) rear end until locking latch snaps. Make sure that the rider seat is properly secured by gently pulling it upwards. Remove key from the lock.

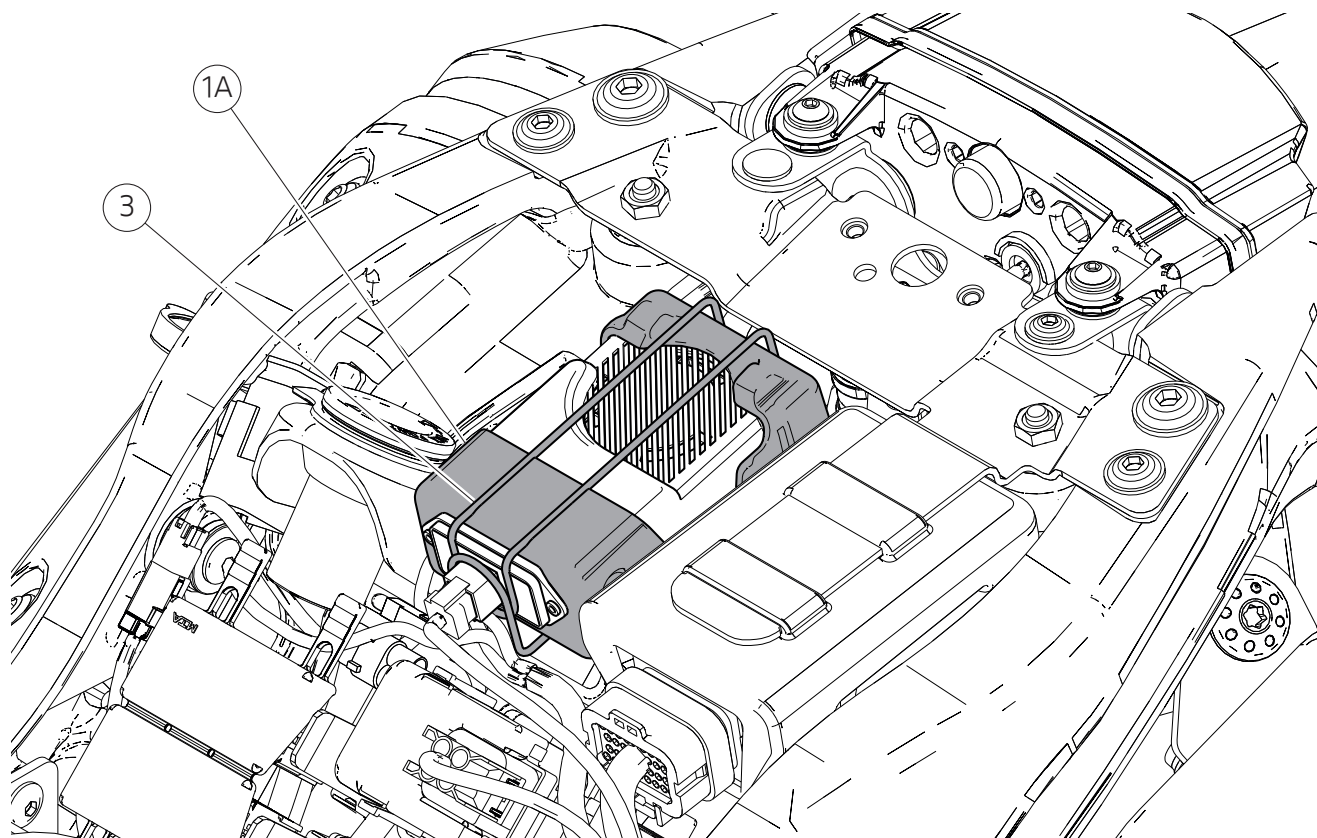
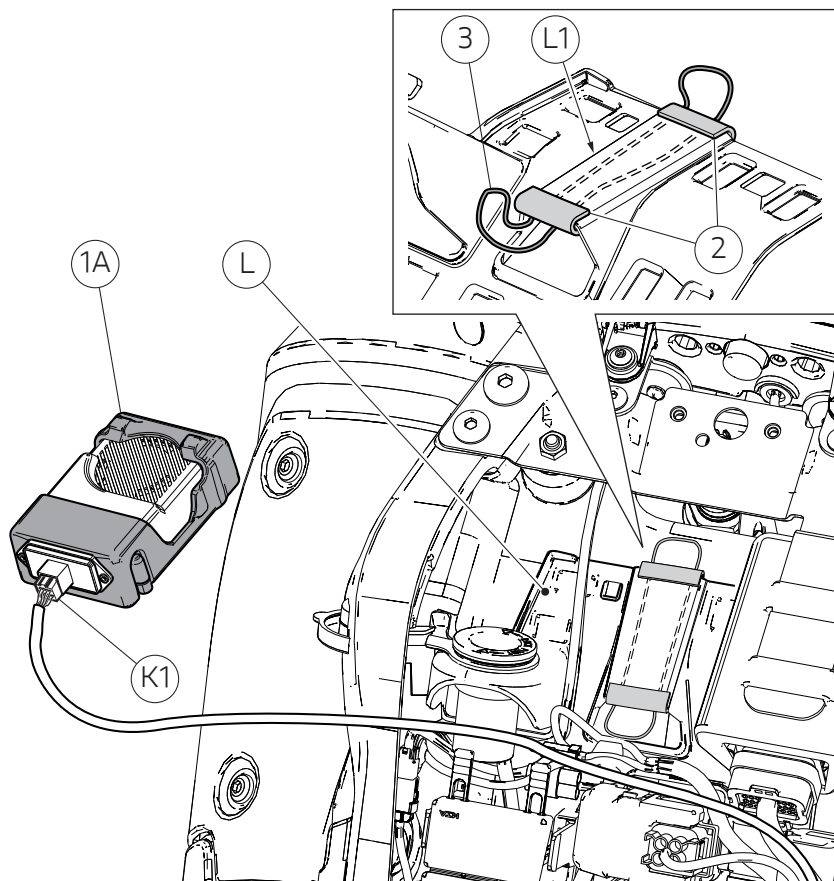
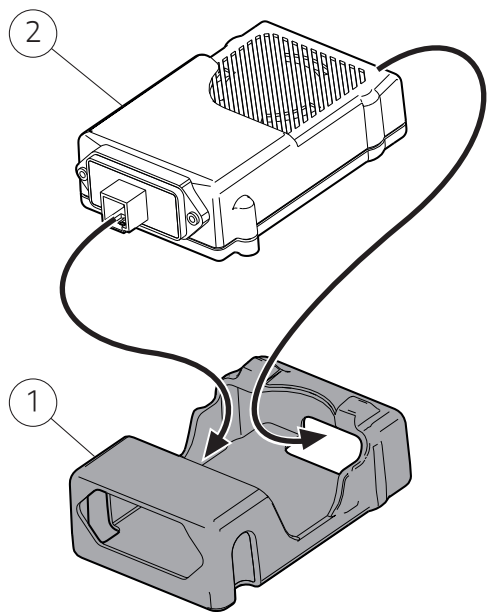

Montaggio componenti kit (versioni Scrambler 1100)



Importante

Verificare, prima del montaggio, che tutti i componenti risultino puliti e in perfetto stato. Adottare tutte le precauzioni necessarie per evitare di danneggiare qualsiasi parte nella quale ci si trova ad operare.

Montaggio centralina

Inserire la centralina (N) nel supporto antivibrante (1) calzandola prima dal lato dotato di connessione, poi dall'altro. Applicare i n. 2 gommini (2) sul profilo del supporto componenti elettrici (L) come mostrato in figura. Inserire l'OR (3) nell'apertura (L1). Posizionare il gruppo centralina (1A) e fissarla tramite l'OR (3) come mostrato in figura. Collegare il connettore (K1) al gruppo centralina (1A).

Rimontaggio sella



Note

Prima di rimontare la sella occorre eseguire la procedura di attivazione antifurto. Vedi "Attivazione/Disattivazione antifurto".

Inserire l'estremità anteriore del fondo sella sotto alle sede del supporto telaio. Spingere sull'estremità posteriore della sella fino ad udire lo scatto del chiavistello della serratura. Assicurarsi che la sella sia saldamente fissata al telaio e rimuovere la chiave dalla serratura.

Kit component assembly (Scrambler 1100 versions)



Important

Before assembly, make sure that all parts are clean and in perfect conditions. Take all the necessary measures to avoid damaging any part you are working on.

Fitting the control unit

Insert control unit (N) inside vibration damping support (1) by fitting it first on the side featuring the connection and then on the other side. Place the no. 2 seals (2) on the electrical component support edge (L) as shown in the figure. Place the O-RING (3) in the slot (L1). Position control unit assembly (1A) and secure it by means of O-ring (3), as shown in the figure. Connect connector (K1) to control unit assembly (1A).

Refitting the seat



Notes

Before refitting seat, carry out the anti-theft system activation procedure. See "Activating/deactivating anti-theft system".

Slide the front end of the seat bottom underneath the seat of the frame support. Press on seat rear end until locking latch snaps. Make sure that the seat is firmly secured to the frame and remove the key from the lock.

X1

L1

L2

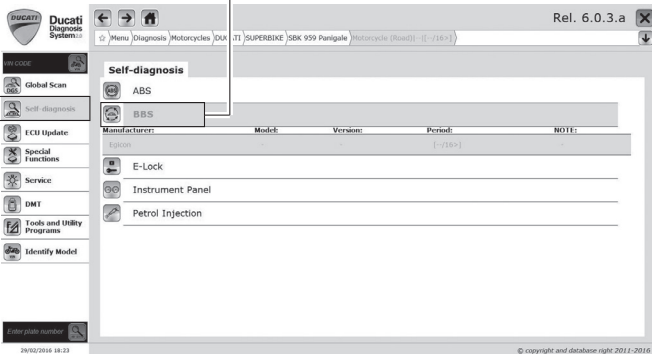

X2

L3

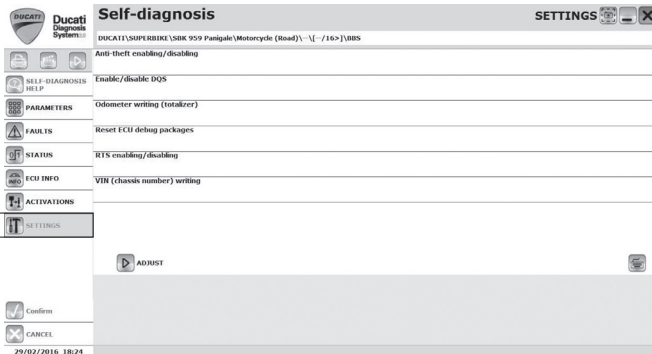

X3

L5

L4

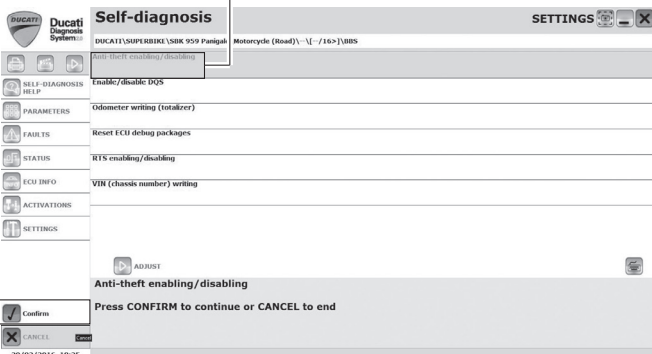

X4

L6

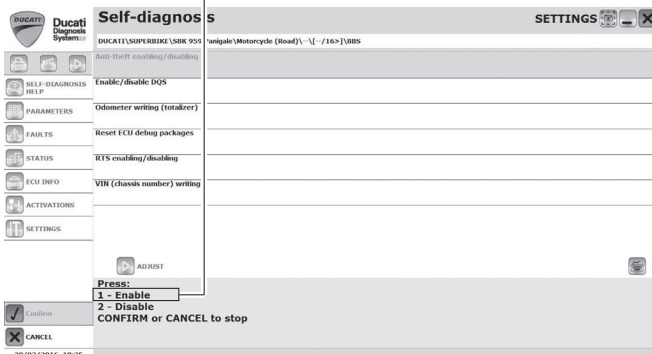

X5

L7

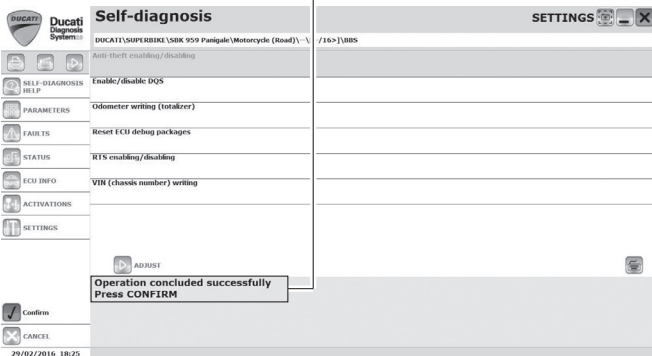

X6

L8

L9

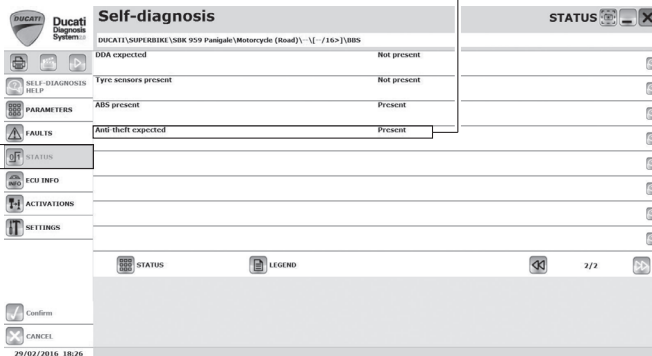

Attivazione/Disattivazione antifurto

Collegare lo strumento di diagnosi al connettore acquisizione dati. Selezionare il modello corretto di motoveicolo. Selezionare l'ambiente "Self-diagnosis" (L1) nel menù a sinistra e successivamente il comando "BBS" (L2), come indicato in figura (X1). Selezionare l'ambiente "Settings" (L3) nel menù a sinistra, come indicato in figura (X2). Selezionare la funzione "Anti-theft enabling/disabling" (L4) e successivamente "Confirm" (L5), come indicato in figura (X3). Premere sulla tastiera del PC il numero "1) Enable" (L6) per abilitare la presenza dell'antifurto, come indicato in figura (X4). Attendere la conferma della operazione, tramite messaggio "Operation concluded successfully" (L7), come indicato in figura (X5). Selezionare l'ambiente "Status" (L8) nel menù a sinistra e verificare che effettivamente lo stato della centralina antifurto sia "present" (L9), come indicato in figura (X6). In caso contrario ripetere i punti precedenti.

Anti-theft system enabling/disabling

Connect the diagnostic tool to the data acquisition socket. Select the correct motorcycle model. Select "Self-diagnosis" (L1) from the menu on the left and then "BBS" (L2), as shown in figure (X1). Select "Settings" (L3) from the menu on the left, as shown in figure (X2). Select the "Anti-theft enabling/disabling" function (L4) and then "Confirm" (L5), as shown in figure (X3). Press number "1) Enable" (L6) on PC keyboard to enable the anti-theft system, as shown in figure (X4). Wait for the confirmation message "Operation concluded successfully" (L7), as shown in figure (X5). Select "Status" (L8) from the menu on the left and make sure that the status of the anti-theft control unit is actually "present" (L9), as shown in figure (X6). If this is not the case, repeat the points above.

レース専用部品 ご注文書

ご注文商品

1	P/N	商品名
2	P/N	商品名
3	P/N	商品名
4	P/N	商品名
5	P/N	商品名

お客様ご記入欄

私は上記レース専用部品を下記車両に装着し、サーキット走行のみに利用し、一般公道には利用しません。

車台番号 ZDM	モデル名
お客様署名	ご注文日

ドウカティ正規ネットワーク店記入欄

お客様に上記レース専用部品を販売し、レース専用部品のご利用方法を説明いたしました。

販売店署名	販売日	年	月	日
-------	-----	---	---	---

販売店様へお願い

- 上記ご記入の上、弊社アフターセールス部までFAXしてください。FAX : 03 - 6692 - 1317
- 取り付け車両 1台に 1枚でご使用ください。

Kit montaggio antifurto / Anti-theft system installation set / Kit de pose antivol / Montagekit Diebstahlsicherung / Conjunto para a montagem do dispositivo antirroubo / Kit montaje antirrobo / 盗難防止装置取り付けキット - 96680531B

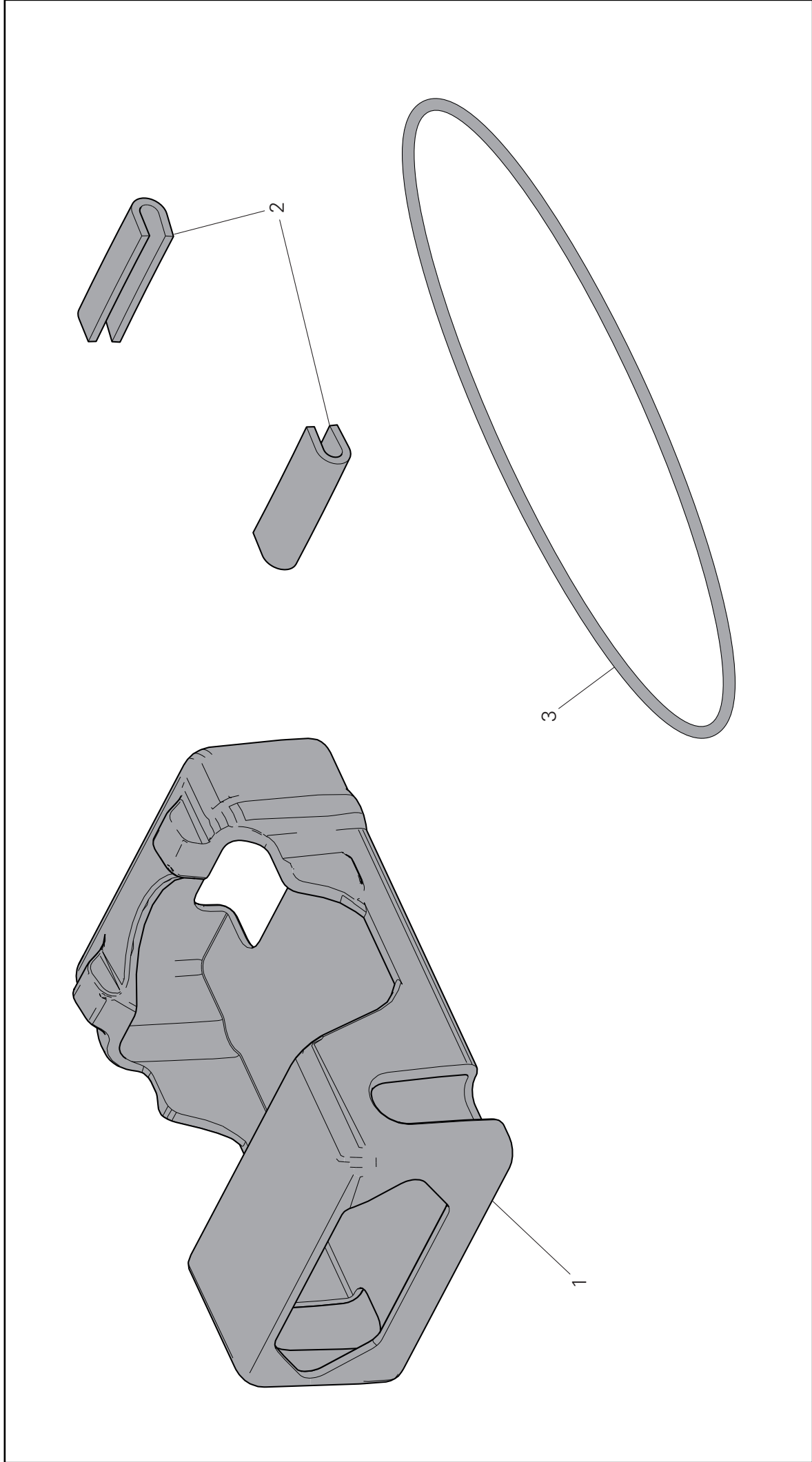

Pos.	Cod.	Denominazione	Description	Designation	Bezeichnung	Descrição	Denominacion	説明	Q.ty
1	96610521A	Supporto antivibrante	Vibration damping support	Support antivibratoire	Schwingungsdämpfer der Halter	Supporte antivibrações	Soporte antivibrante	耐震ダンパーマウント	1
2	78510181A	Gommino	Grommet	Plot caoutchouc	Gummielement	Borracha	Aro de goma	ラバー	2
3	88642131A	OR per fissaggio	Fixing O-RING	Joint torique de fixation	O-Ring für Befestigung	OR para fixação	Junta tórica de fijación	固定用 Oリング	1