

Kit telaietti borse laterali morbide Soft side pannier subframe kit



Simbologia

Per una lettura rapida e razionale sono stati impiegati simboli che evidenziano situazioni di massima attenzione, consigli pratici o semplici informazioni.

Prestare molta attenzione al significato dei simboli, in quanto la loro funzione è quella di non dovere ripetere concetti tecnici o avvertenze di sicurezza. Sono da considerare, quindi, dei veri e propri "promemoria".

Consultare questa pagina ogni volta che sorgeranno dubbi sul loro significato.



Attenzione

La non osservanza delle istruzioni riportate può creare una situazione di pericolo e causare gravi lesioni personali e anche la morte.



Importante

Indica la possibilità di arrecare danno al veicolo e/o ai suoi componenti se le istruzioni riportate non vengono eseguite.



Note

Fornisce utili informazioni sull'operazione in corso.

Riferimenti

I particolari evidenziati in grigio e riferimento numerico (Es. ①) rappresentano l'accessorio da installare e gli eventuali componenti di montaggio forniti a kit.

I particolari con riferimento alfabetico (Es. A) rappresentano i componenti originali presenti sul motoveicolo.

Tutte le indicazioni destro o sinistro si riferiscono al senso di marcia del motociclo.

Avvertenze generali



Attenzione

Le operazioni riportate nelle pagine seguenti devono essere eseguite da un tecnico specializzato o da un'officina autorizzata DUCATI.



Attenzione

Le operazioni riportate nelle pagine seguenti se non eseguite a regola d'arte possono pregiudicare la sicurezza del pilota.



Note

Documentazione necessaria per eseguire il montaggio del Kit è il MANUALE OFFICINA, relativo al modello di moto in vostro possesso.



Note

Nel caso fosse necessaria la sostituzione di un componente del kit consultare la tavola ricambi allegata.

Symbols

To allow quick and easy consultation, this manual uses graphic symbols to highlight situations in which maximum care is required, as well as practical advice or information.

Pay attention to the meaning of the symbols since they serve to avoid repeating technical concepts or safety warnings throughout the text. The symbols should therefore be seen as real reminders. Please refer to this page whenever in doubt as to their meaning.



Warning

Failure to follow these instructions might give rise to a dangerous situation and provoke severe personal injuries or even death.



Caution

Failure to follow these instructions might cause damages to the vehicle and/or its components.



Notes

Useful information on the procedure being described.

References

Parts highlighted in grey and with a numeric reference (Example ①) are the accessory to be installed and any assembly components supplied with the kit.

Parts with an alphabetic reference (Example A) are the original components fitted on the vehicle.

Any right- or left-hand indication refers to the vehicle direction of travel.

General notes



Warning

Carefully perform the operations on the following pages since they might negatively affect rider safety.



Warning

Carefully perform the operations on the following pages since they might negatively affect rider safety.



Notes

The following documents are necessary for assembling the Kit: WORKSHOP MANUAL of your bike model.



Notes

Should it be necessary to change any kit parts, please refer to the attached spare part table.

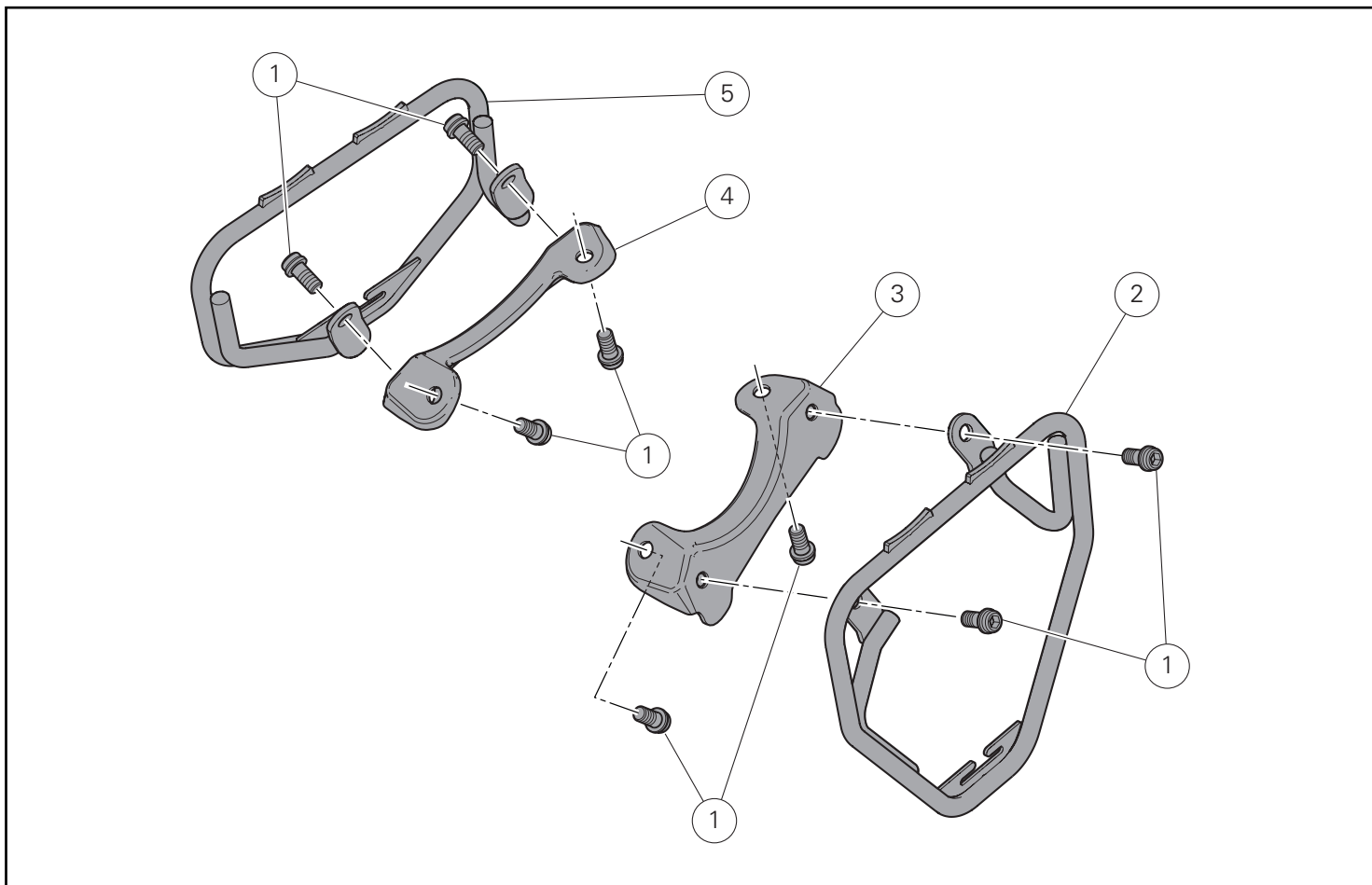

Pos.	Denominazione	Description
1	Vite TCEIF M8x16	TCEIF screw M8x16
2	Telaietto supporto borse sinistro	LH pannier support subframe
3	Piastra supporto borse sinistra	LH pannier support plate
4	Piastra supporto borse destra	RH pannier support plate
5	Telaietto supporto borse destro	RH pannier support subframe

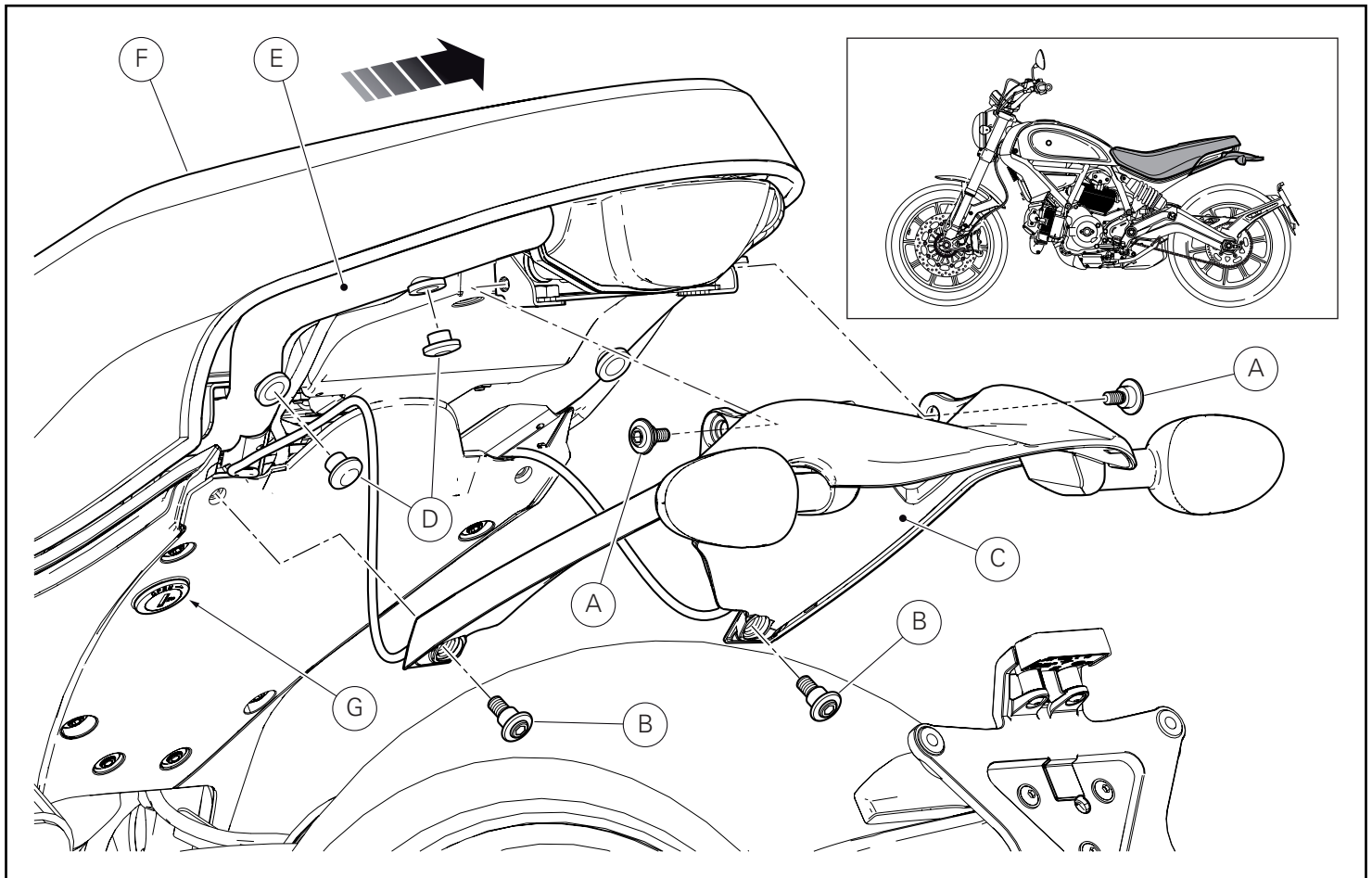

Smontaggio componenti originali

Introdurre la chiave nella serratura (G), ruotarla in senso orario e contemporaneamente premere verso il basso in prossimità del chiavistello per agevolare lo sgancio del piolo.
Sfilare la sella (F) dai fermi anteriori tirandola all'indietro.
Svitare le n.2 viti superiori (A) e le n.2 viti inferiori (B) di fissaggio del gruppo tegolino posteriore (C).
Sfilare e supportare adeguatamente il gruppo tegolino posteriore (C) prestando attenzione a non rovinare i cablaggi degli indicatori di direzione.
Rimuovere i n.4 tappi (D) dal telaio (E).

Removing the original components

Insert the key in the lock (G), turn the key clockwise and simultaneously press downward in the area of the latch to release the pin.
Pull the seat (F) backwards to release it from the front retainers.
Undo the 2 upper screws (A) and the 2 lower screws (B) securing rear guard assembly (C).
Slide rear guard assembly (C) out and properly support it paying attention not to damage turn indicator wiring.
Remove 4 plugs (D) from frame (E).

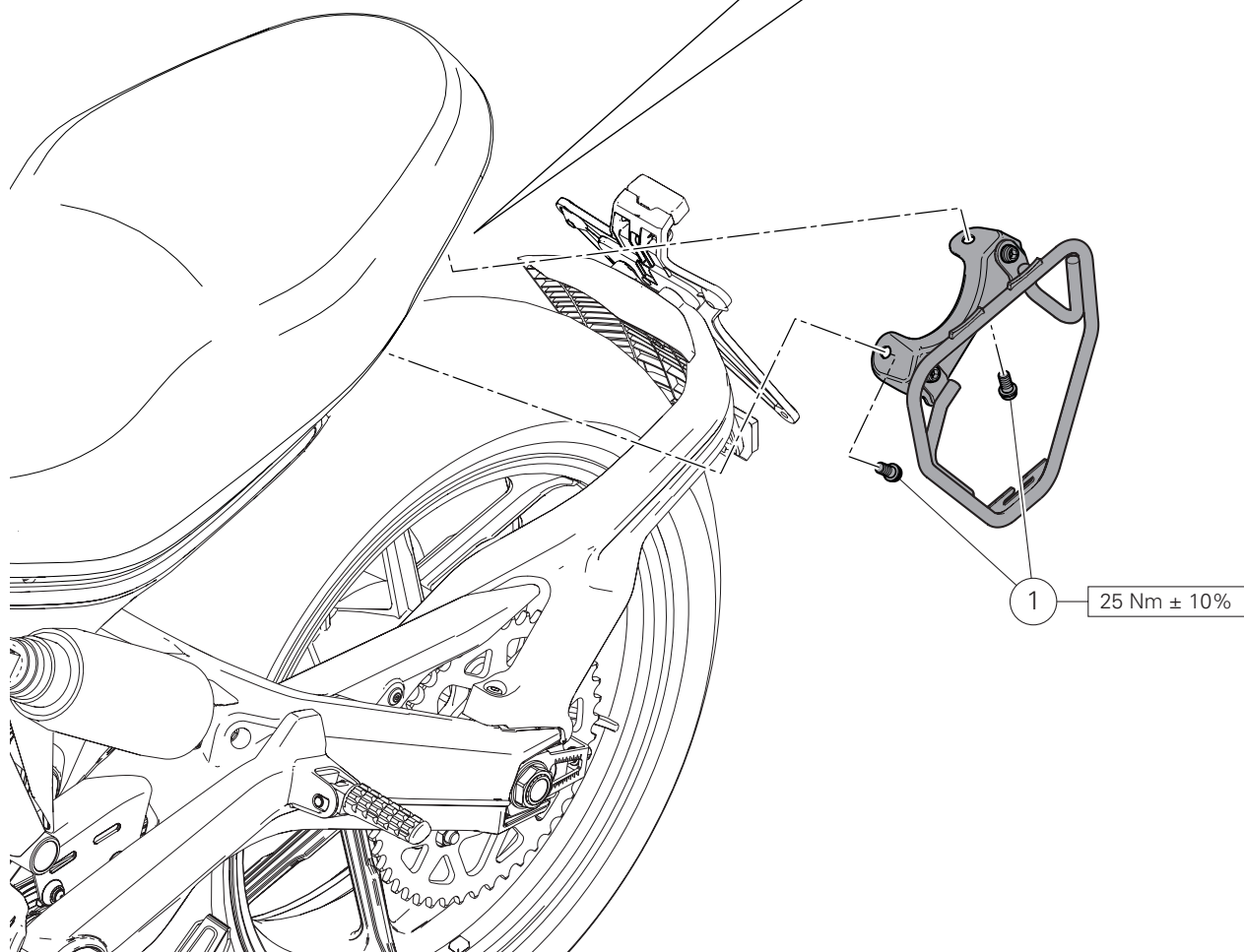
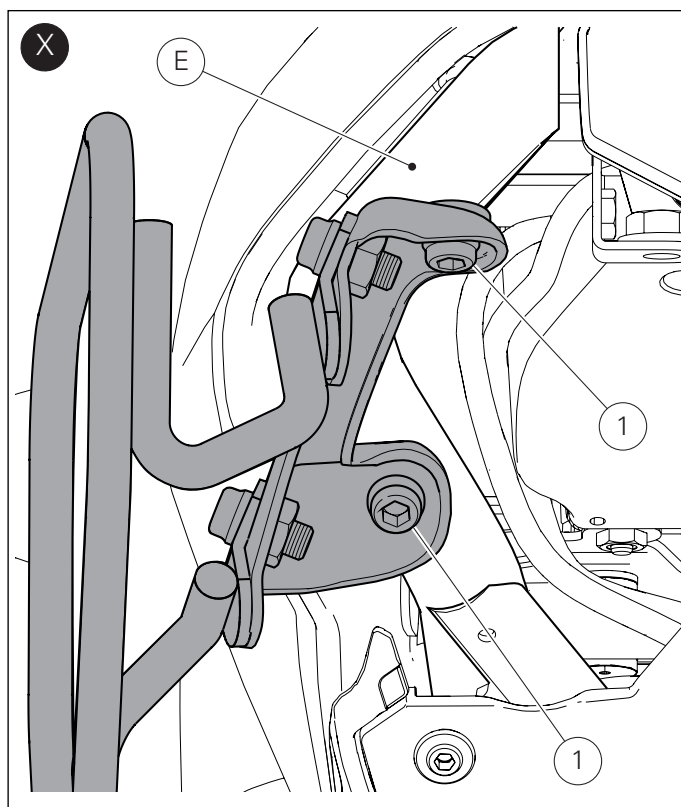
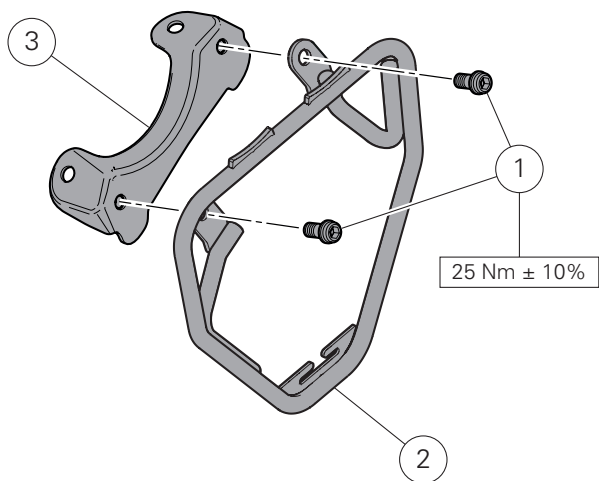

Montaggio componenti kit



Importante

Verificare, prima del montaggio, che tutti i componenti risultino puliti e in perfetto stato.
Adottare tutte le precauzioni necessarie per evitare di danneggiare qualsiasi parte nella quale ci si trova ad operare.

Premontaggio gruppo telaietto sinistro

Premontare la piastra supporto borse sinistra (3) sul telaietto sinistro (2) impuntando le n.2 viti (1).
Serrare le n.2 viti (1) alla coppia indicata.

Montaggio gruppo telaietto sinistro

Fissare il gruppo telaietto sinistro al telaio (E) impuntando le n.2 viti (1), come indicato in figura (X).
Serrare le n.2 viti (1) alla coppia indicata.

Kit installation



Caution

Check that all components are clean and in perfect condition before installation.
Adopt any precaution necessary to avoid damages to any part of the motorcycle you are working on.

LH subframe unit pre-assembly

Pre-assemble LH pannier support plate (3) on LH subframe (2) by starting the 2 screws (1).
Tighten the 2 screws (1) to the specified torque.

LH subframe unit assembly

Secure LH subframe unit to frame (E) by starting the 2 screws (1), as shown in figure (X).
Tighten the 2 screws (1) to the specified torque.

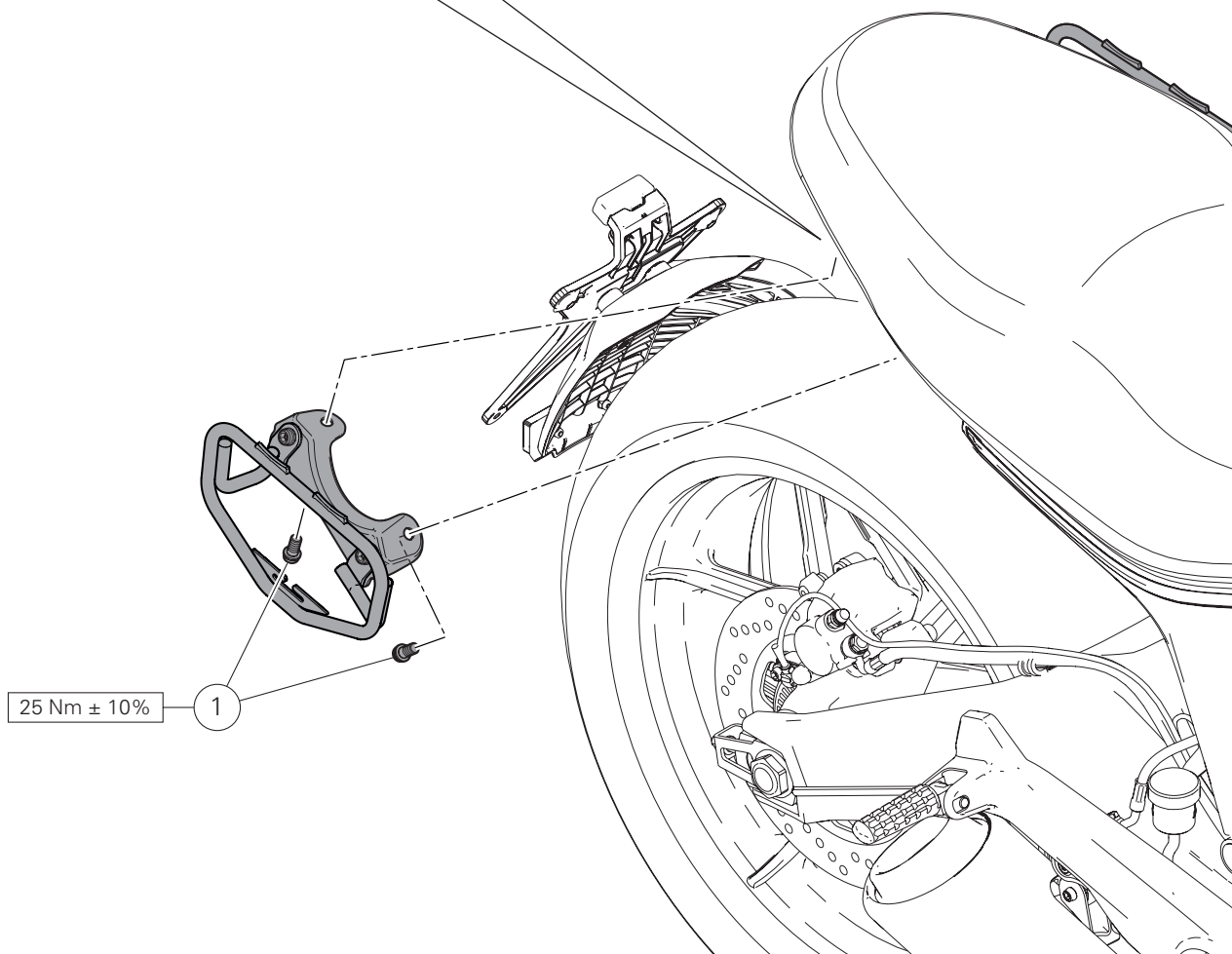
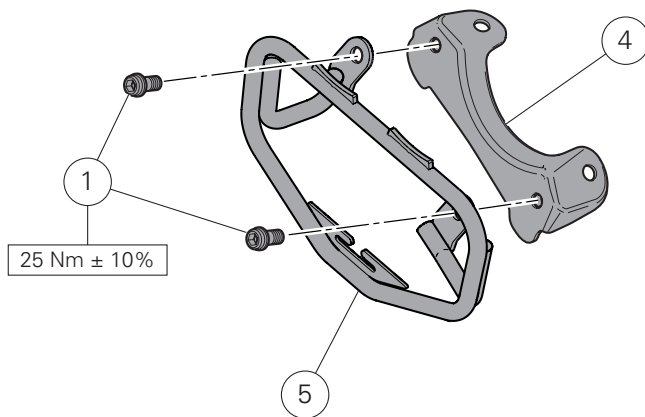
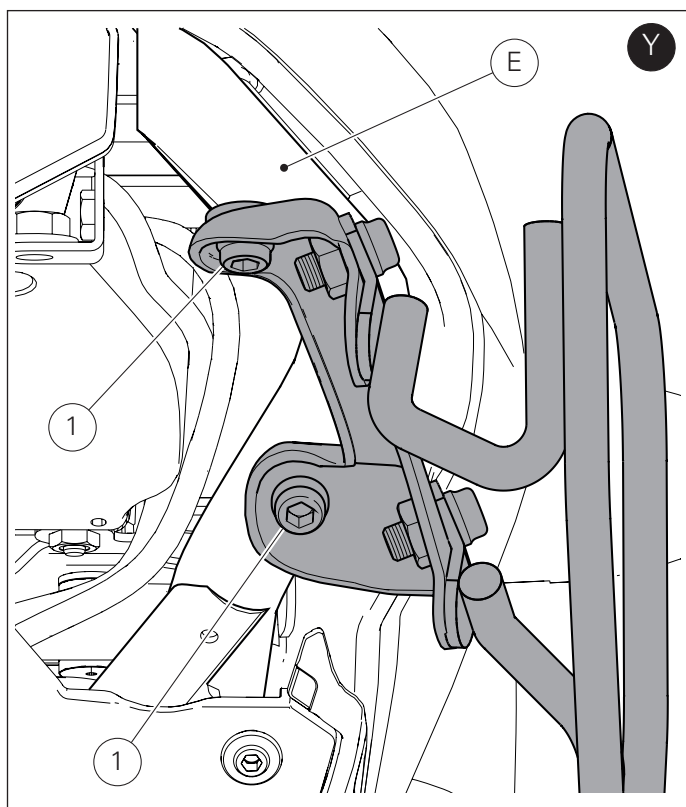

Premontaggio gruppo telaietto destro

Premontare la piastra supporto borse destra (4) sul telaietto destro (5) impuntando le n.2 viti (1).
Serrare le n.2 viti (1) alla coppia indicata.

RH subframe unit pre-assembly

Pre-assemble RH pannier support plate (4) on RH subframe (5) by starting the 2 screws (1).
Tighten the 2 screws (1) to the specified torque.

Montaggio gruppo telaietto destro

Fissare il gruppo telaietto destro al telaio (E) impuntando le n.2 viti (1), come indicato in figura (Y).
Serrare le n.2 viti (1) alla coppia indicata.

RH subframe unit assembly

Secure RH subframe unit to frame (E) by starting the 2 screws (1), as shown in figure (Y).
Tighten the 2 screws (1) to the specified torque.

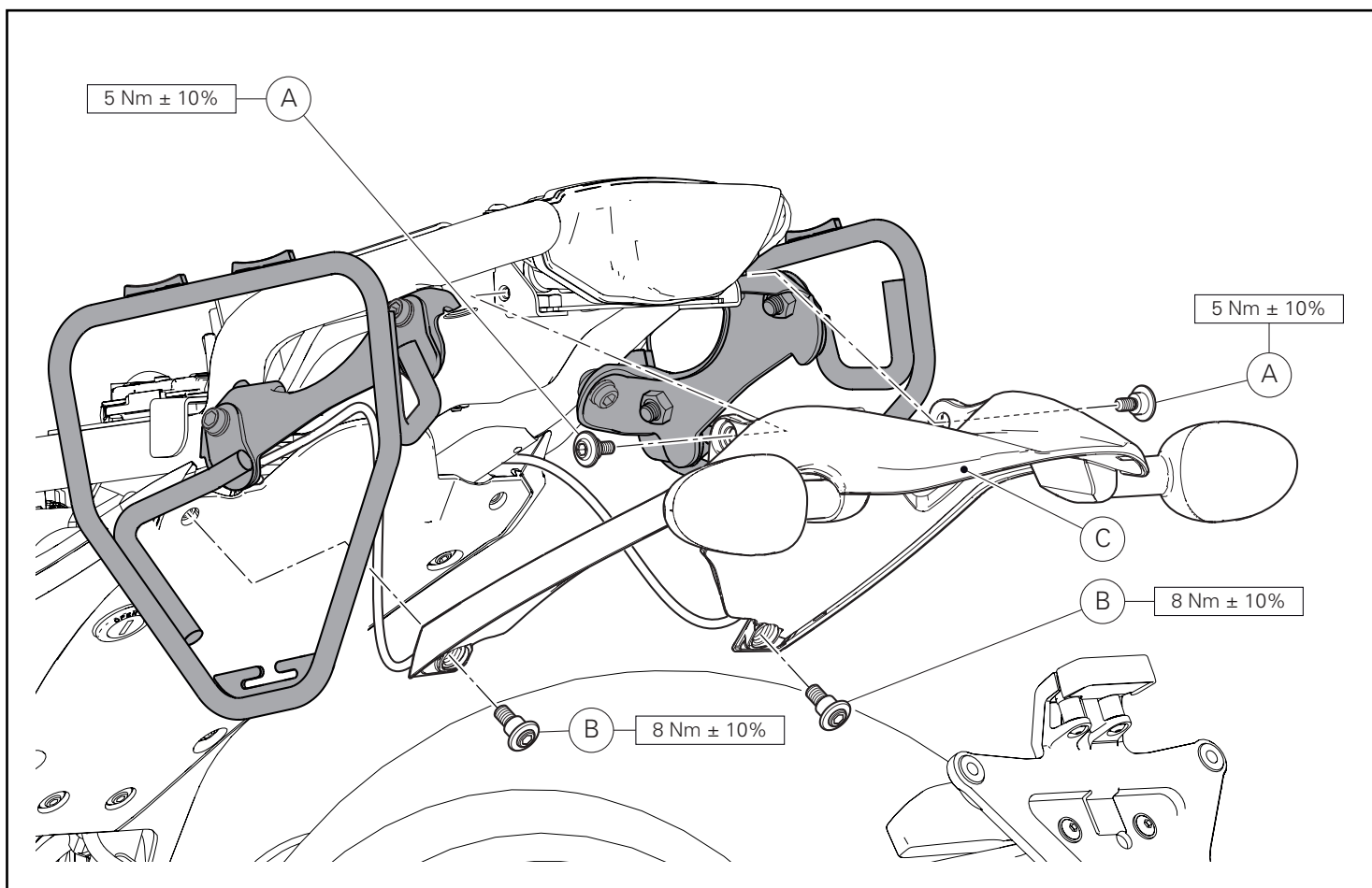

Posizionare il gruppo tegolino posteriore (C) sul telaio e impuntare le n.2 viti superiori (A).

Impuntare le n.2 viti inferiori (B) di fissaggio del gruppo tegolino posteriore (C) al telaio.

Fissare il gruppo tegolino posteriore (C) serrando le n.2 viti superiori (A) e le n.2 viti inferiori (B) alla coppia indicata.

Position rear guard assembly (C) on frame and start the 2 upper screws (A).

Start the 2 lower screws (B) that fasten rear guard assembly (C) to frame.

Fix rear guard assembly (C) tightening the 2 upper screws (A) and the 2 lower screws (B) to the specified torque.

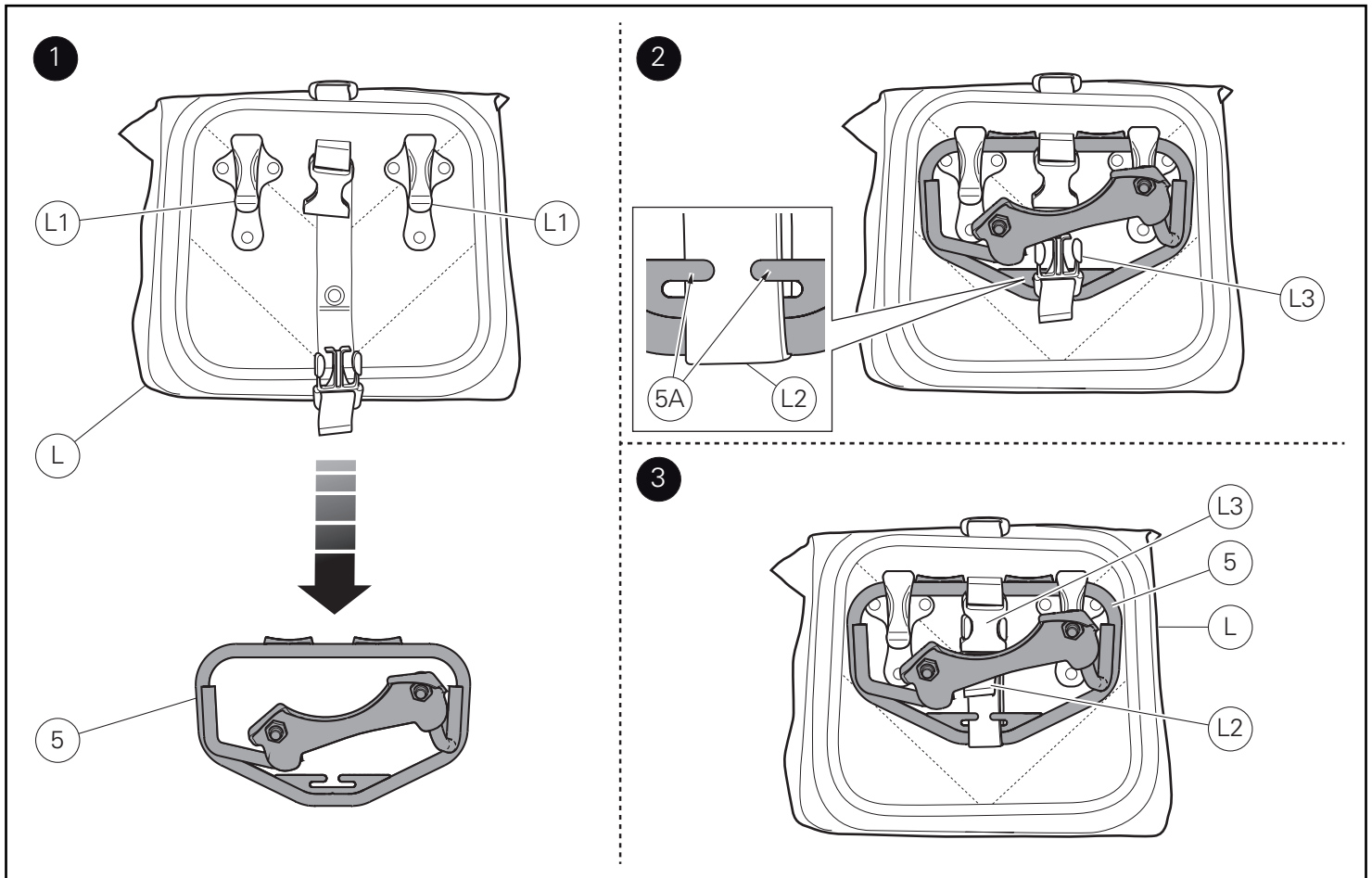

Montaggio borse laterali



Note

Sul kit telaietto (96780741A) è possibile montare il Kit borse laterali stagne URBAN ENDURO (96780751A) e il Kit borse laterali morbide CLASSIC (96780761A).



Note

È possibile acquistare presso ad un concessionario/dealer autorizzato il Kit borse laterali stagne URBAN ENDURO (96780751A) e il Kit borse laterali morbide CLASSIC (96780761A).



Note

Per comprendere meglio l'aggancio della borsa sul rispettivo telaietto viene rappresentato il gruppo telaietto supporto borsa smontato dal motoveicolo.

Appoggiare gli agganci (L1) della borsa destra (L) al telaietto destro (5) e spingere verso il basso fino a sentire lo scatto, come mostrato in figura (1).

Far passare la cinghia (L2) della borsa all'interno del telaietto e inserirla nella alette inferiori (5A) come mostrato in figura (2).

Agganciare la fibbia (L3) e tirare la cinghia (L2) per fissare correttamente la borsa destra (L) al telaietto destro (5), come mostrato in figura (3).

Ripetere la stessa operazione per agganciare la borsa sinistra (M) al telaietto sinistro (2).

Assembling the side panniers



Notes

On the subframe kit (96780741A) it is possible to assemble the URBAN ENDURO waterproof side pannier kit (96780751A) and the CLASSIC side soft bag kit (96780761A).



Notes

The URBAN ENDURO waterproof side pannier kit (96780751A) and the CLASSIC side soft bag kit (96780761A) can be purchased at an authorized dealer.



Notes

To better understand pannier securing on relevant subframe, pannier support subframe unit is represented removed from the motorcycle.

Lay right pannier (L) retainers (L1) onto right subframe (5) and push down until hearing a click, as shown in figure (1).

Drive strap (L2) of the pannier inside the subframe and fit it in the lower tabs (5A) as shown in figure (2).

Close buckle (L3) and pull strap (L2) to correctly secure RH pannier (L) to RH subframe (5), as shown in figure (3).

Repeat the same procedure to fasten left pannier (M) to left subframe (2).

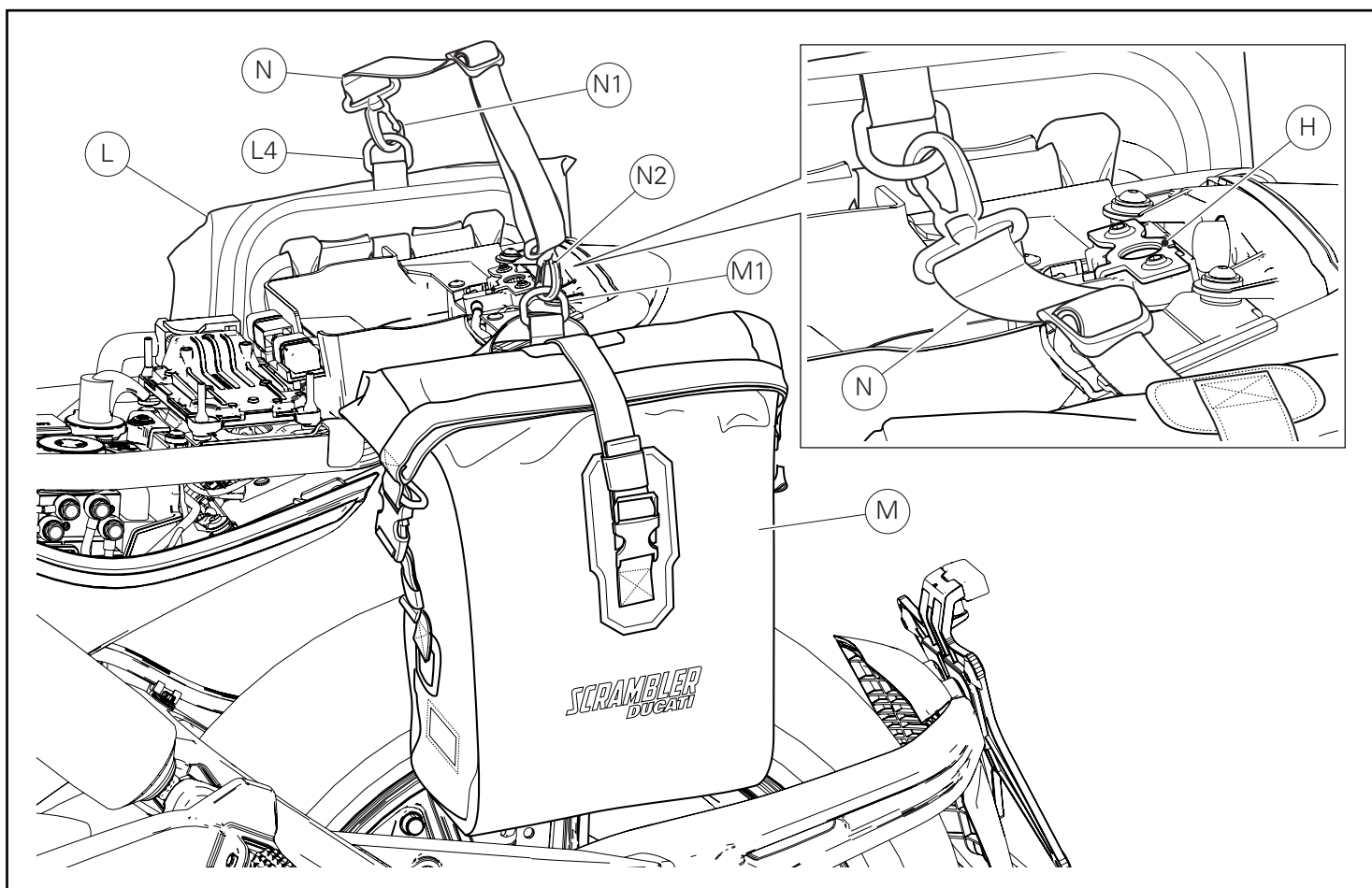

Dopo aver montato entrambe le borse occorre legarle tra di loro con la cinghia di sicurezza (N).

Agganciare la cinghia di sicurezza (N) con l'apposito moschettone (N1) all'anello (L4) presente sulla borsa destra (L).

Agganciare l'altra estremità della cinghia di sicurezza (N) all'anello (M1) presente sulla borsa sinistra (M), utilizzando il moschettone (N2).

Tensionare la cinghia di sicurezza (N).



Attenzione

La cinghia di sicurezza (N) non deve coprire l'aggancio (H) della chiusura della sella.



Attenzione

Controllare periodicamente l'integrità della cinghia di sicurezza (N) e dei rispettivi moschettoni (N1) ed (N2).

After fitting both panniers, fasten them to one another using safety belt (N).

Use the suitable snap hook (N1) to fasten safety belt (N) to ring (L4) on right pannier (L).

Fasten the other end of safety belt (N) to ring (M1) on left pannier (M), using snap hook (N2).

Tension safety belt (N).



Warning

Safety belt (N) must not cover hook (H) of seat closing.



Warning

Periodically check safety belt (N) and relevant snap hooks (N1) and (N2) conditions.

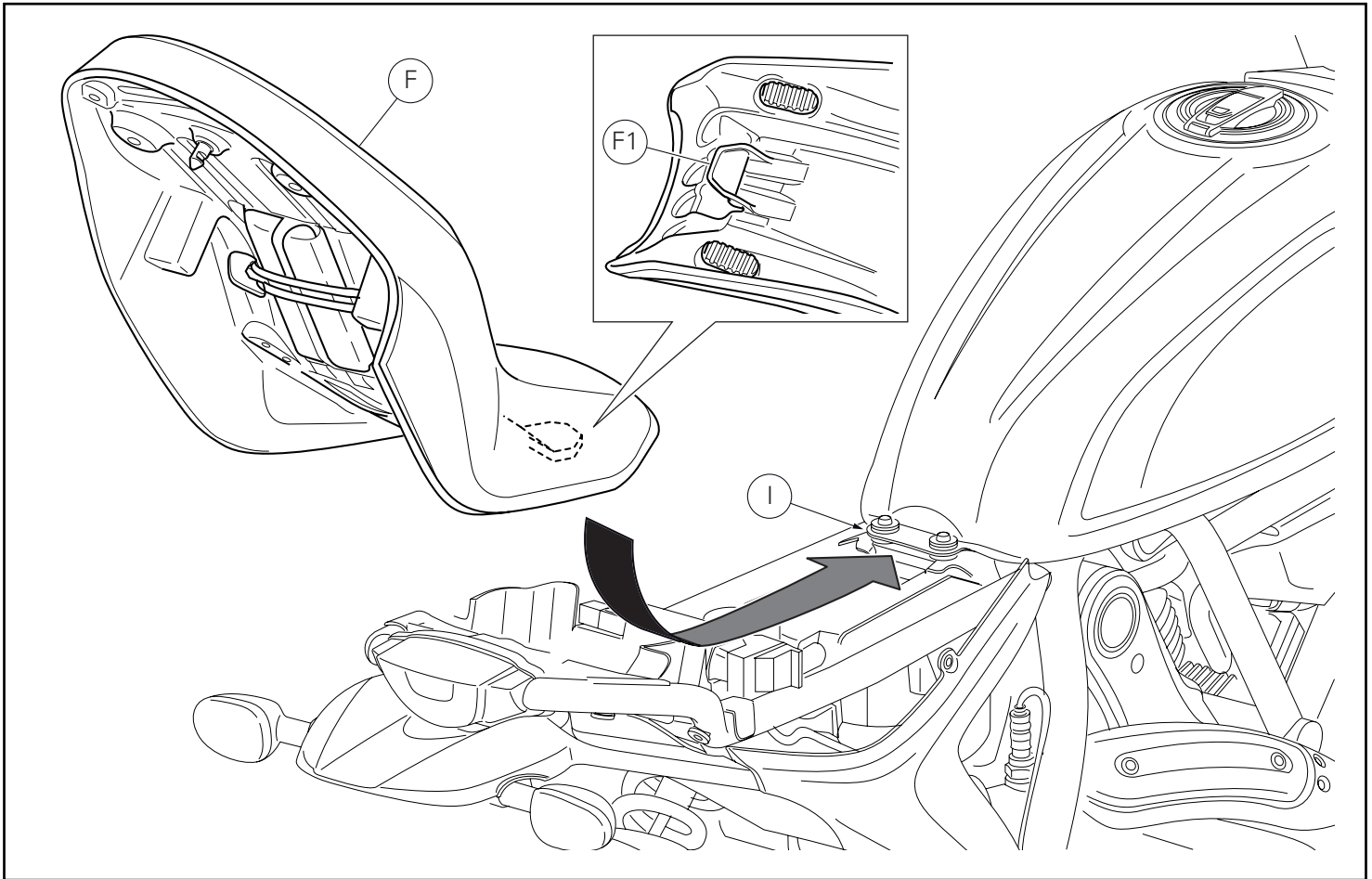

Assicurarsi che tutti gli elementi siano correttamente disposti e fissati nel vano sotto la sella.

Inserire l'estremità anteriore (F1) del fondo sella sotto alle sede (I) del supporto telaio.

Spingere sull'estremità posteriore della sella (F) fino ad udire lo scatto del chiavistello della serratura.

Assicurarsi che la sella sia saldamente fissata al telaio e rimuovere la chiave dalla serratura.



Attenzione

È fatto obbligo di rispettare i limiti di velocità imposti dal paese in cui ci si trova a circolare e comunque è vietato oltrepassare i 130 Km/h con le borse laterali montate sulla moto.



Importante

La continua e prolungata esposizione agli agenti atmosferici potrebbe determinare dei minimi o sensibili cambiamenti nel colore dei tessuti/materiali.



Attenzione

Il peso massimo trasportabile dalle borse laterali è di 3 Kg per la borsa sinistra e 1,5 Kg per la destra.

Nel caso si ecceda il peso consigliato si rischia la rottura delle borse stesse.

Questo può influire negativamente sulla sicurezza del pilota.



Importante

Quando si effettua il lavaggio della moto è necessario rimuovere le borse laterali.

Make sure that all parts are correctly arranged and secured in the compartment under the seat.

Slide the front end (F1) of the seat bottom underneath the seat (I) of the frame support.

Press on seat (F) rear end until locking latch snaps.

Make sure that the seat is firmly secured to the frame and remove the key from the lock.



Warning

Always respect the speed limits in force in the country where bike is ridden and, anyway, do not exceed 130 Km/h with the side panniers installed on bike.



Caution

Continuous and prolonged exposure to weather may create minor discoloration in the fabrics/materials.



Warning

Side pannier maximum loading capacity is 3 Kg for left pannier and 1.5 for right pannier.

Should this weight be exceeded, panniers could break.

This can affect rider's safety.



Caution

When washing the bike, always remove side panniers.

NOTE / NOTES

Series of horizontal dotted lines for taking notes.

Kit sous-cadres valises latérales souples Kit Halterahmen weiche Seitenkoffer



Symboles

Pour faciliter la consultation de ce manuel, des symboles signalent des situations exigeant le maximum d'attention, des conseils pratiques ou de simples informations. Lire attentivement la signification de ces symboles car ils renvoient à des concepts techniques ou des consignes de sécurité de la plus grande importance. Ils doivent être considérés comme de véritables « aide-mémoire ». Toujours consulter cette page en cas de doute concernant leur signification.



Attention

La non-observance des instructions reportées ci-dessous peut créer une situation dangereuse et provoquer de graves lésions personnelles voire la mort.



Important

Indique la possibilité d'endommager le véhicule et/ou ses composants si les instructions reportées ci-dessous ne sont pas suivies.



Remarques

Fournit des informations utiles sur l'opération en cours.

Références

Les pièces surlignées en gris et la référence numérique (Ex. ①) représentent l'accessoire à installer et les composants de montage éventuels fournis en kit.

Les pièces avec référence alphabétique (Ex. Ⓐ) représentent les composants d'origine présents sur le motorcycle.

Toutes les indications droite ou gauche se réfèrent au sens de marche la moto.

Avertissements généraux



Attention

Les opérations indiquées dans les pages suivantes, au cas où elles ne seraient pas effectuées selon les règles de l'art pourraient compromettre la sécurité du pilote.



Attention

Les opérations indiquées dans les pages suivantes, au cas où elles ne seraient pas effectuées selon les règles de l'art pourraient compromettre la sécurité du pilote.



Remarques

La documentation nécessaire pour effectuer la pose du Kit est le : MANUEL D'ATELIER, relatif au modèle de moto en votre possession.



Remarques

Au cas où il serait nécessaire d'effectuer le remplacement d'un composant du kit, il faudra consulter la planche relative aux pièces détachées ci-jointe.

Symbole

Zum schnellen und übersichtlichen Lesen werden Symbole verwendet, die außerordentlich wichtige Situationen, praktische Ratschläge oder auch nur einfache Informationen hervorheben. Der Bedeutung dieser Symbole ist besondere Aufmerksamkeit zu schenken, da sich hierdurch das ständige Wiederholen von technischen Konzepten oder Sicherheitshinweisen erübrigt. Sie stellen daher regelrechte „Merker“ dar. Diese Seite ist immer dann zur Hand zu nehmen, wenn Zweifel über die Bedeutung eines Symbols bestehen sollten.



Achtung

Eine Nichtbeachtung der hier wiedergegebenen Anweisungen kann Gefahrensituationen schaffen und zu schweren Verletzungen und auch zum Tod führen.



Wichtig

Weist darauf hin, dass bei Nichteinhaltung der hier wiedergegebenen Anweisungen die Möglichkeit für Schäden am Fahrzeug und/oder seiner Komponenten besteht.



Hinweis

Übermittelt nützliche Informationen zum betreffenden Arbeitseingriff.

Bezugsangaben

Die grau gekennzeichneten Bestandteile mit numerischem Bezug (Bsp. ①) geben das zu installierende Bestandteil und die eventuellen, im Kit enthaltenen Montagekomponenten wieder.

Die Bestandteile mit alphabetischem Bezug (Bsp. Ⓐ) geben die Original-Bestandteile wieder, die am Motorrad verbaut wurden.

Alle Angaben wie „rechts“ oder „links“ beziehen sich auf die Fahrtrichtung des Motorrads.

Allgemeine Warnhinweise



Achtung

Werden die auf den folgenden Seiten beschriebenen Arbeitsmaßnahmen nicht fachgerecht ausgeführt, kann sich dies auf die Sicherheit des Fahrers auswirken.



Achtung

Werden die auf den folgenden Seiten beschriebenen Arbeitsmaßnahmen nicht fachgerecht ausgeführt, kann sich dies auf die Sicherheit des Fahrers auswirken.



Hinweis

Für die Montage des Kits sind folgende Unterlagen erforderlich: WERKSTATTHANDBUCH, des sich in Ihrem Besitz befindlichen Motorrads.



Hinweis

Sollte sich der Austausch eines Bestandteils des Kits als erforderlich erweisen, ist dazu Bezug auf die beiliegende Ersatzteilliste zu nehmen.

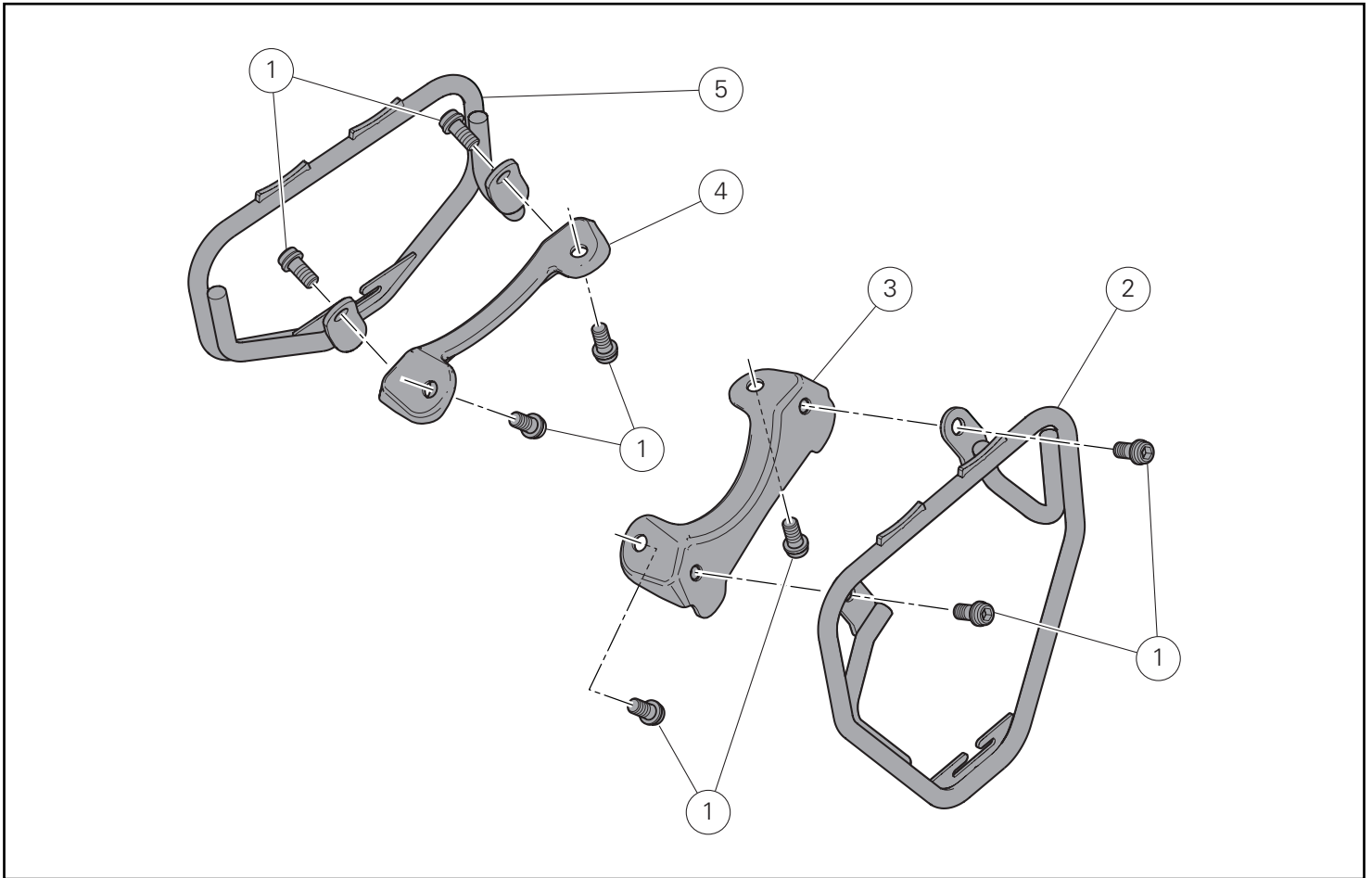

Pos.	Designation	Bezeichnung
1	Vis TCHC M8 x 16	Geflanschte Innensechskantschraube M8x16
2	Sous-cadre support valises gauche	Linker Kofferhalterahmen
3	Plaque de support valises gauche	Linke Kofferhalterplatte
4	Plaque de support valises droite	Rechte Kofferhalterplatte
5	Sous-cadre de support valises droit	Rechter Kofferhalterahmen

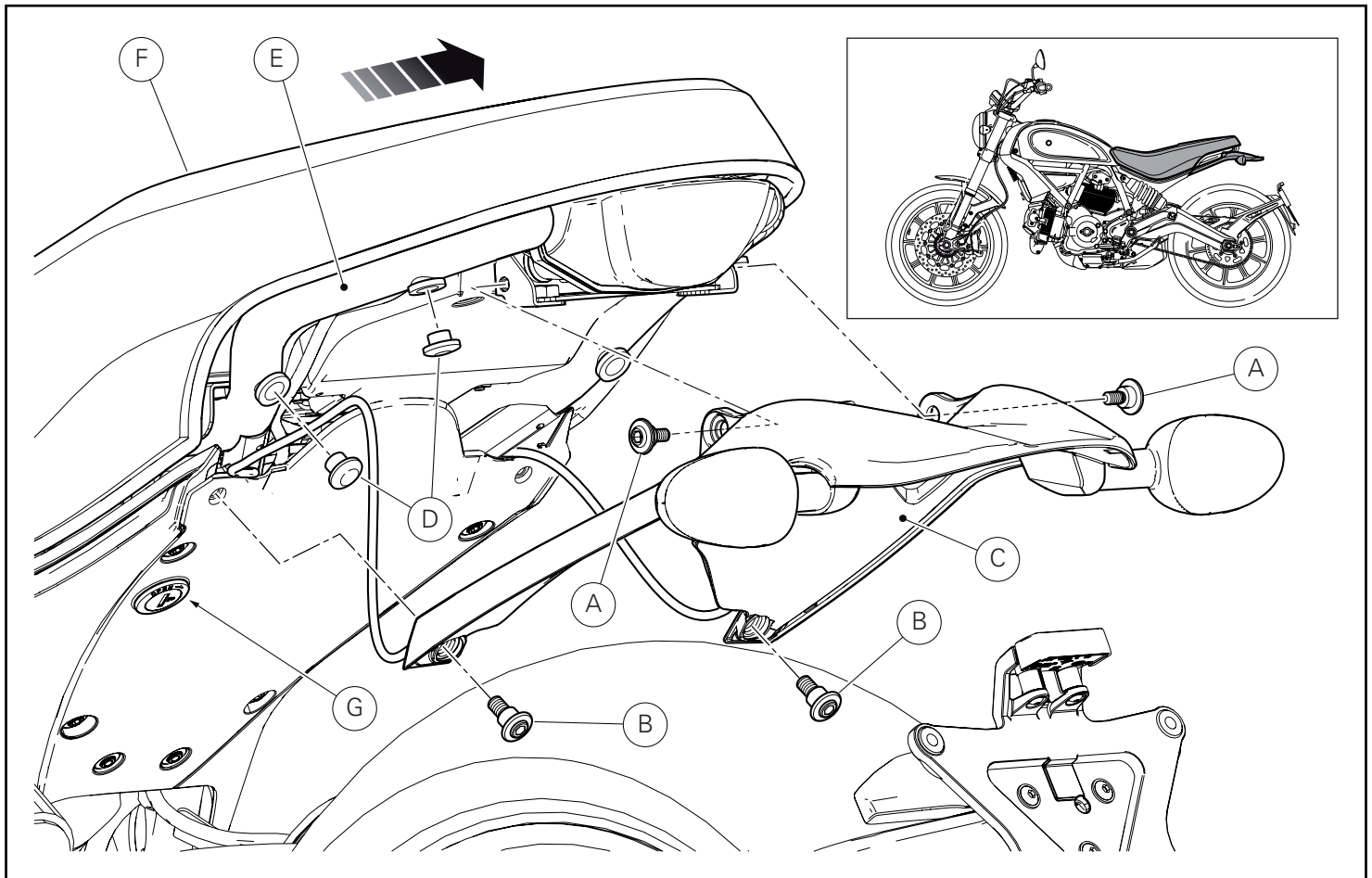

Dépose composants d'origine

Insérer la clé dans la serrure (G), la tourner dans le sens des aiguilles d'une montre et, en même temps, exercer une pression vers le bas à proximité du verrou pour faciliter le décrochage de la vis sans tête.

Sortir la selle (F) des arrêtoirs avant en la tirant vers l'arrière.

Desserrer les 2 vis supérieures (A) et les 2 vis inférieures (B) de fixation du groupe dossier de selle arrière (C).

Sortir et soutenir correctement le groupe dossier de selle arrière (C) en faisant attention à ne pas endommager les câblages des clignotants.

Enlever les 4 bouchons (D) du cadre (E).

Ausbau der Original-Bestandteile

Den Schlüssel in das Schloss (G) einstecken, im Uhrzeigersinn drehen und dabei gleichzeitig am Riegel nach unten drücken, um das Lösen des Verriegelungsstifts zu erleichtern.

Die Sitzbank (F) durch Ziehen nach hinten von den vorderen Halterungen entfernen.

Die 2 oberen Schrauben (A) und die 2 unteren Schrauben (B) für die Befestigung der hinteren Spritzschutzeinheit (C) lösen.

Die hintere Spritzschutzeinheit (C) in angemessener Weise abziehen und abstützen und dabei darauf achten, dass die Verkabelungen der Blinker nicht beschädigt werden.

Die 4 Verschlüsse (D) vom Rahmen (E) entfernen.

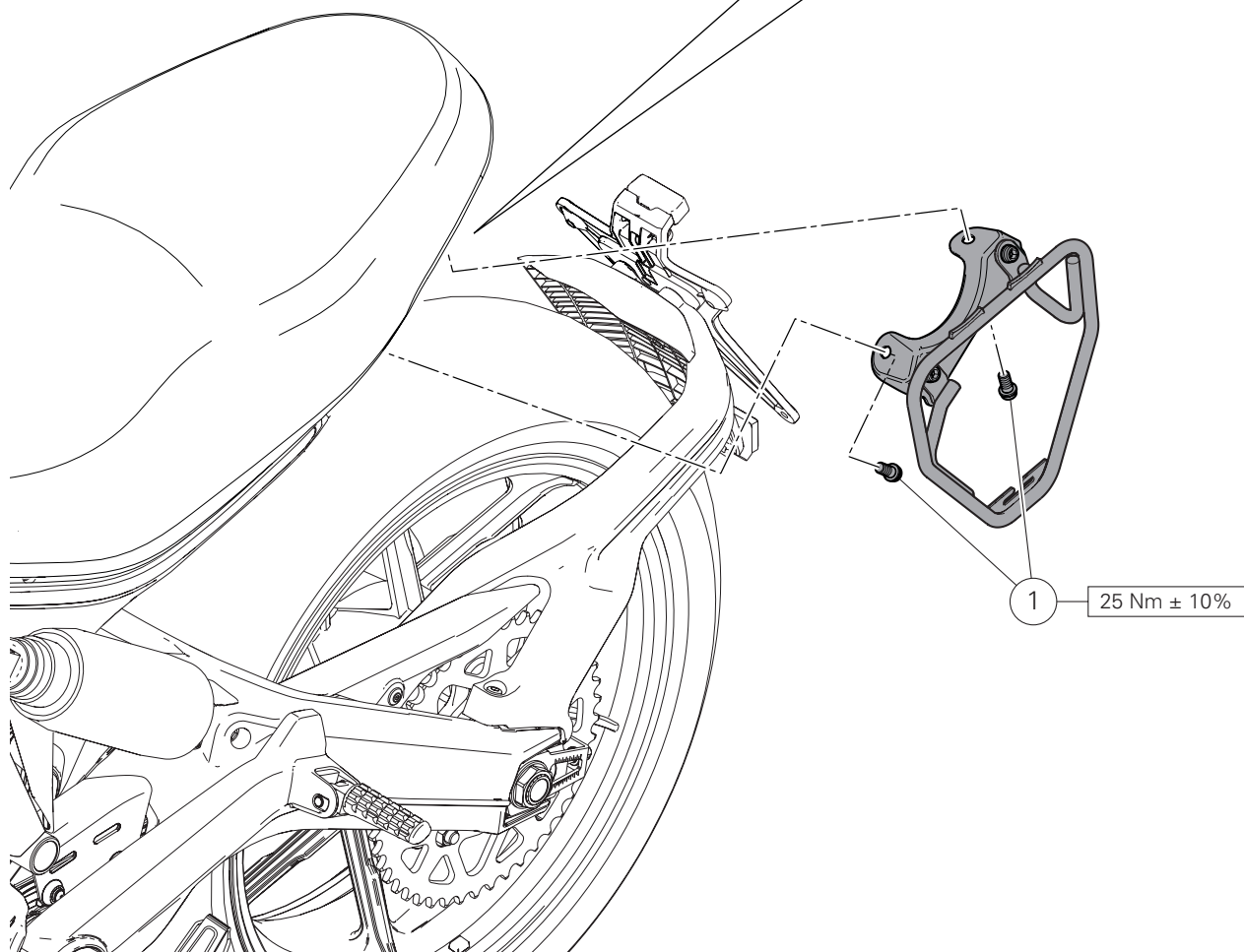
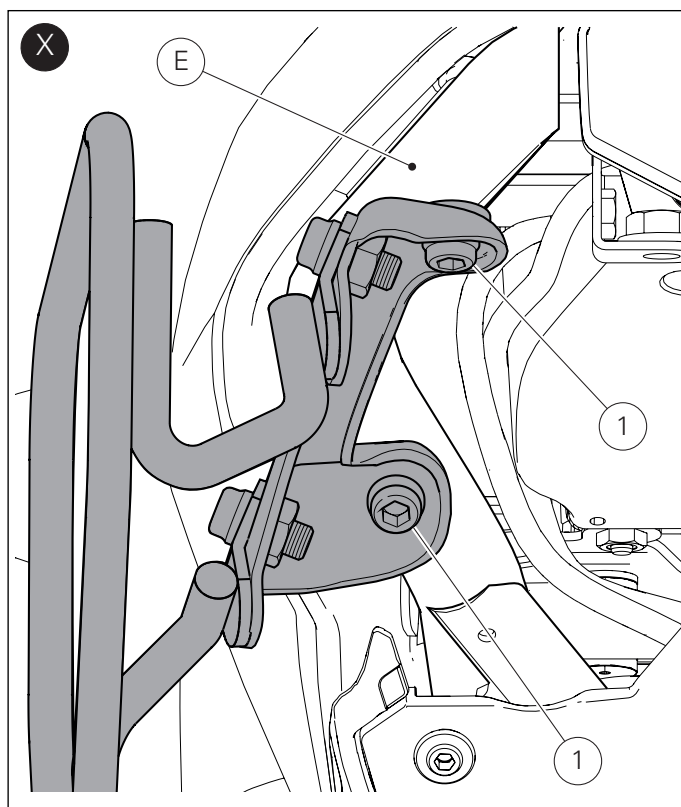
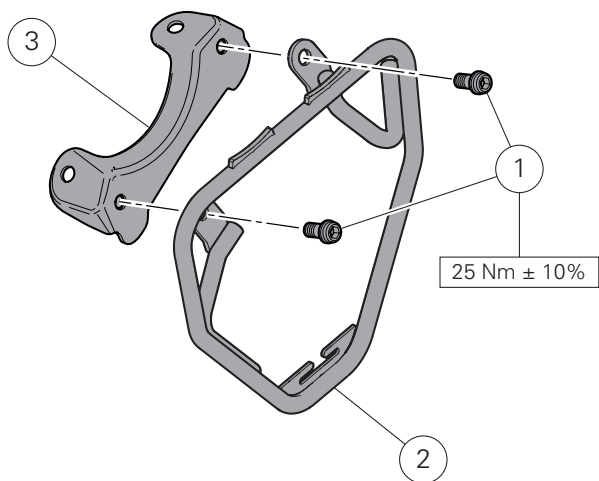

Pose composants kit



Important

Vérifier, avant la pose, que tous les composants sont propres et en parfait état.

Adopter toutes les précautions nécessaires pour éviter d'endommager la surface externe des composants où on opère.

Pré-montage groupe sous-cadre gauche

Pré-monter la plaque de support valises gauche (3) sur le sous-cadre gauche (2) en présentant les 2 vis (1).

Serrer les 2 vis (1) au couple prescrit.

Montage groupe sous-cadre gauche

Fixer le groupe sous-cadre gauche au cadre (E) en présentant les 2 vis (1), comme la figure (X) le montre.

Serrer les 2 vis (1) au couple prescrit.

Montage der Komponenten des Kits



Wichtig

Vor der Montage überprüfen, dass sich alle Komponenten im sauberen und perfekten Zustand befinden.

Alle erforderlichen Vorsichtsmaßnahmen treffen, um eine Beschädigung der Oberflächen der Komponenten, die vom Eingriff betroffen sind, zu vermeiden.

Vormontage der linken Heckrahmeneinheit

Die linke Kofferhalterplatte (3) am linken Heckrahmen (2) durch Ansetzen der 2 Schrauben (1) ansetzen.

Die 2 Schrauben (1) mit dem angegebenen Anzugsmoment anziehen.

Montage der linken Heckrahmeneinheit

Die linke Heckrahmeneinheit am Rahmen (E) durch Ansetzen der 2 Schrauben (1), wie in Abbildung (X) angegeben, befestigen.

Die 2 Schrauben (1) mit dem angegebenen Anzugsmoment anziehen.

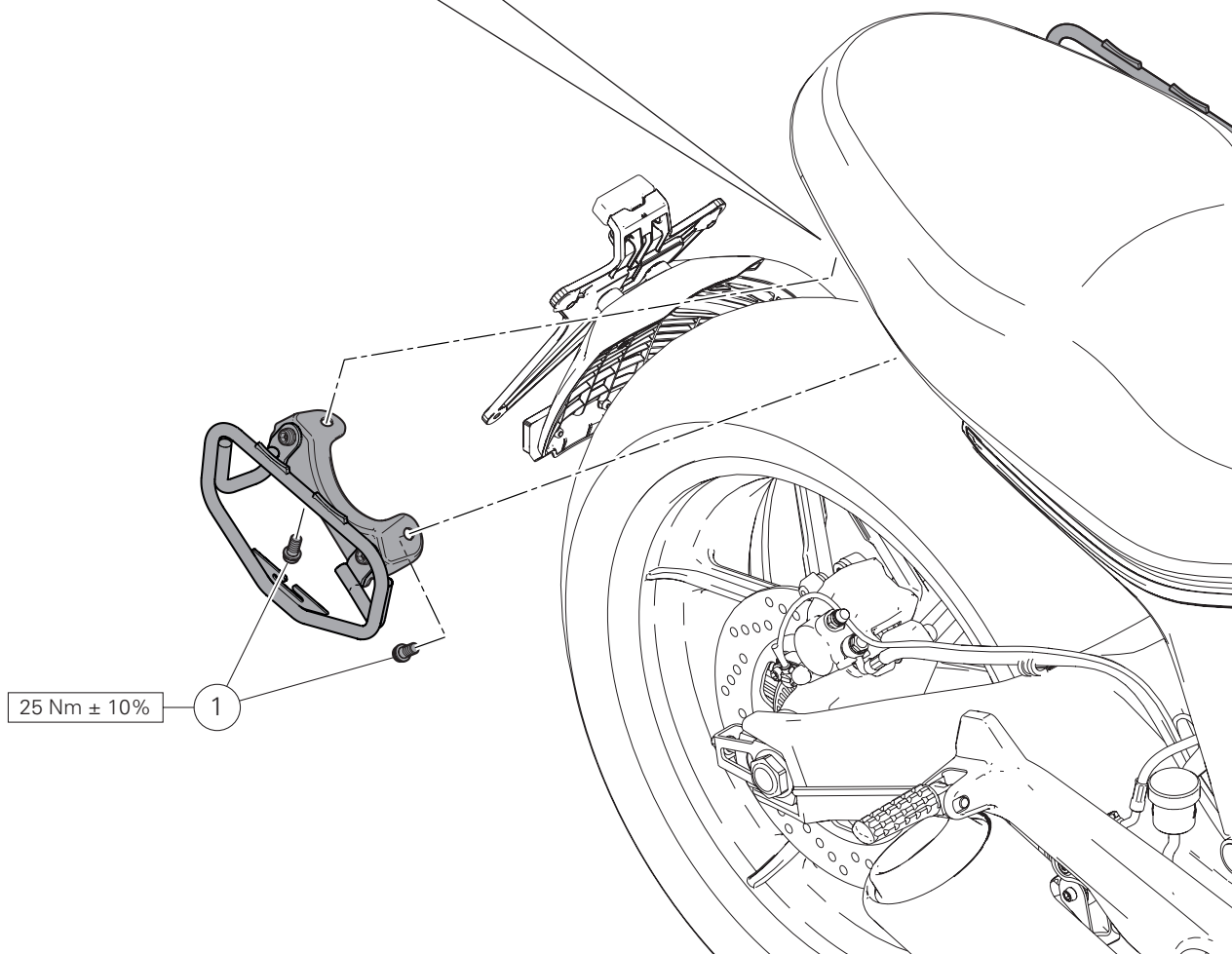
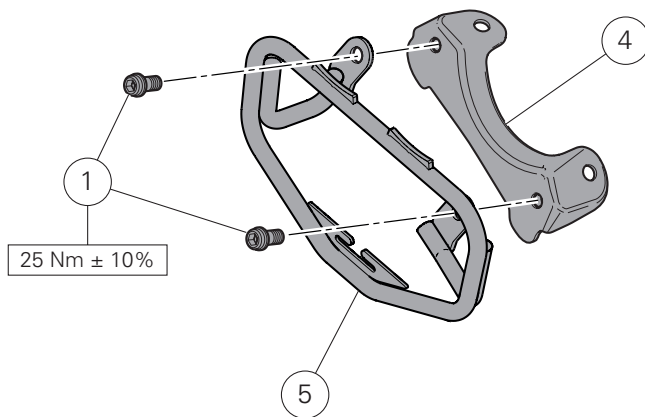
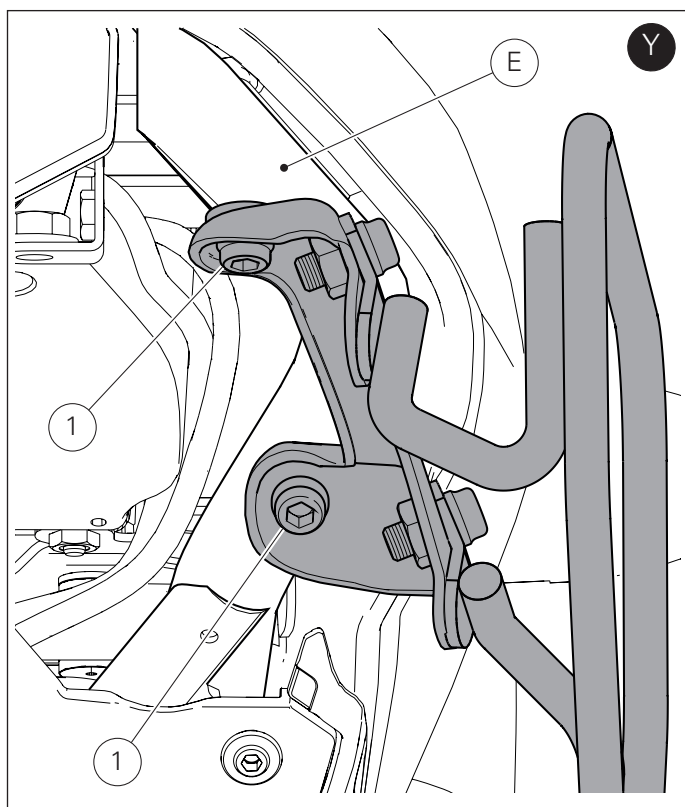

Pré-montage groupe sous-cadre droit

Pré-monter la plaque de support valises droite (4) sur le sous-cadre droit (5) en présentant les 2 vis (1).
Serrer les 2 vis (1) au couple prescrit.

Montage groupe sous-cadre droit

Fixer le groupe sous-cadre droit au cadre (E) en présentant les 2 vis (1), comme la figure (Y) le montre.
Serrer les 2 vis (1) au couple prescrit.

Vormontage der rechten Heckrahmeneinheit

Die rechte Kofferhalterplatte (4) am rechten Heckrahmen (5) durch Ansetzen der 2 Schrauben (1) ansetzen.
Die 2 Schrauben (1) mit dem angegebenen Anzugsmoment anziehen.

Montage der rechten Heckrahmeneinheit

Die rechte Heckrahmeneinheit am Rahmen (E) durch Ansetzen der 2 Schrauben (1), wie in Abbildung (Y) angegeben, befestigen.
Die 2 Schrauben (1) mit dem angegebenen Anzugsmoment anziehen.

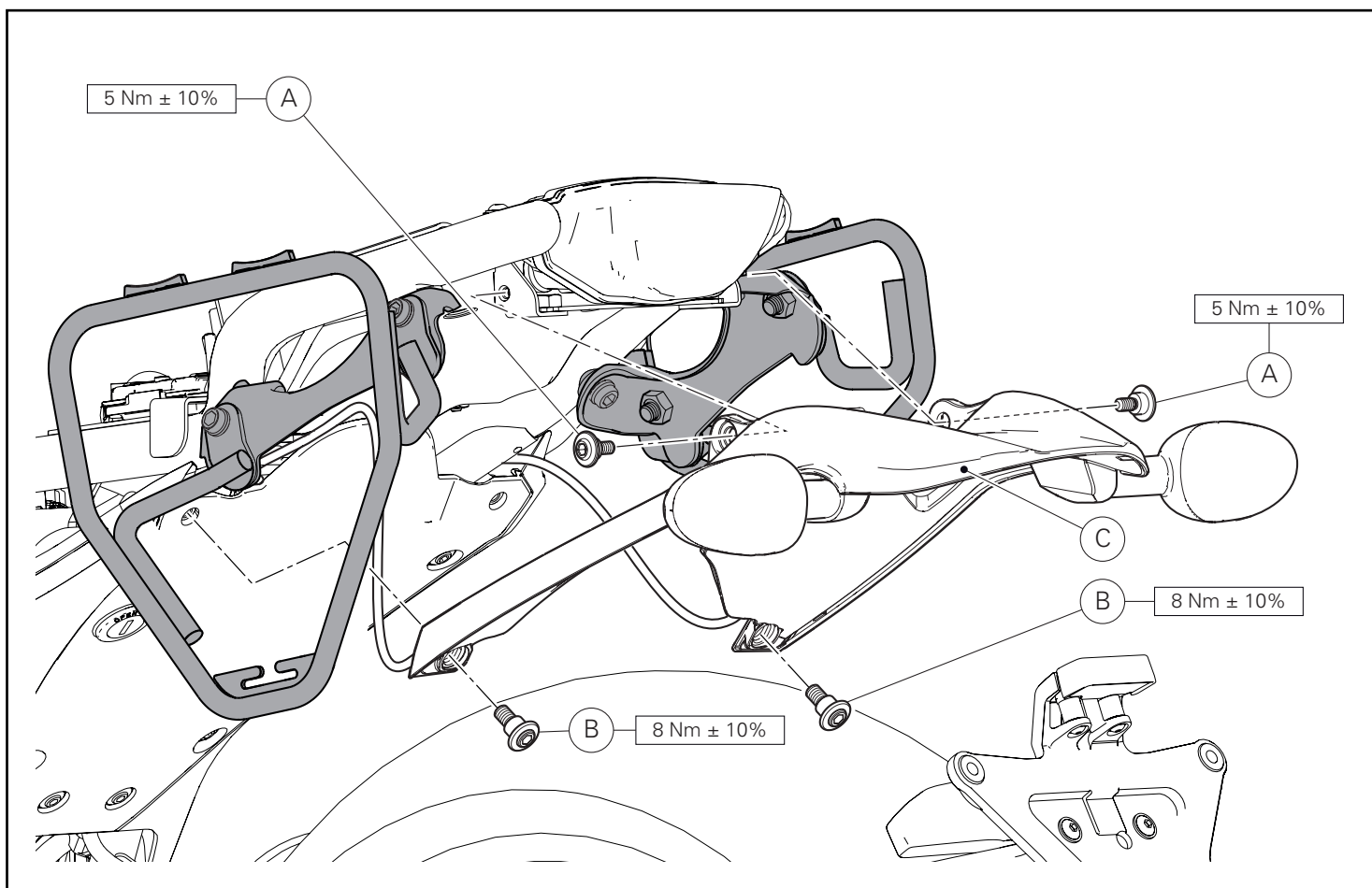

Positionner le groupe dossier de selle arrière (C) sur le cadre et présenter les 2 vis supérieures (A).

Présenter les 2 vis inférieures (B) de fixation du groupe dossier de selle arrière (C) au cadre.

Fixer le groupe dossier de selle arrière (C) en serrant les 2 vis supérieures (A) et les 2 vis inférieures (B) au couple indiqué.

Die hintere Spritzschutzeinheit (C) am Rahmen anordnen und die 2 oberen Schrauben (A) ansetzen.

Die 2 unteren Schrauben (B) für die Befestigung der hinteren Spritzschutzeinheit (C) am Rahmen befestigen.

Die hintere Spritzschutzeinheit (C) durch Anziehen der 2 oberen Schrauben (A) und der 2 unteren Schrauben (B) mit dem angegebenen Anzugsmoment befestigen.

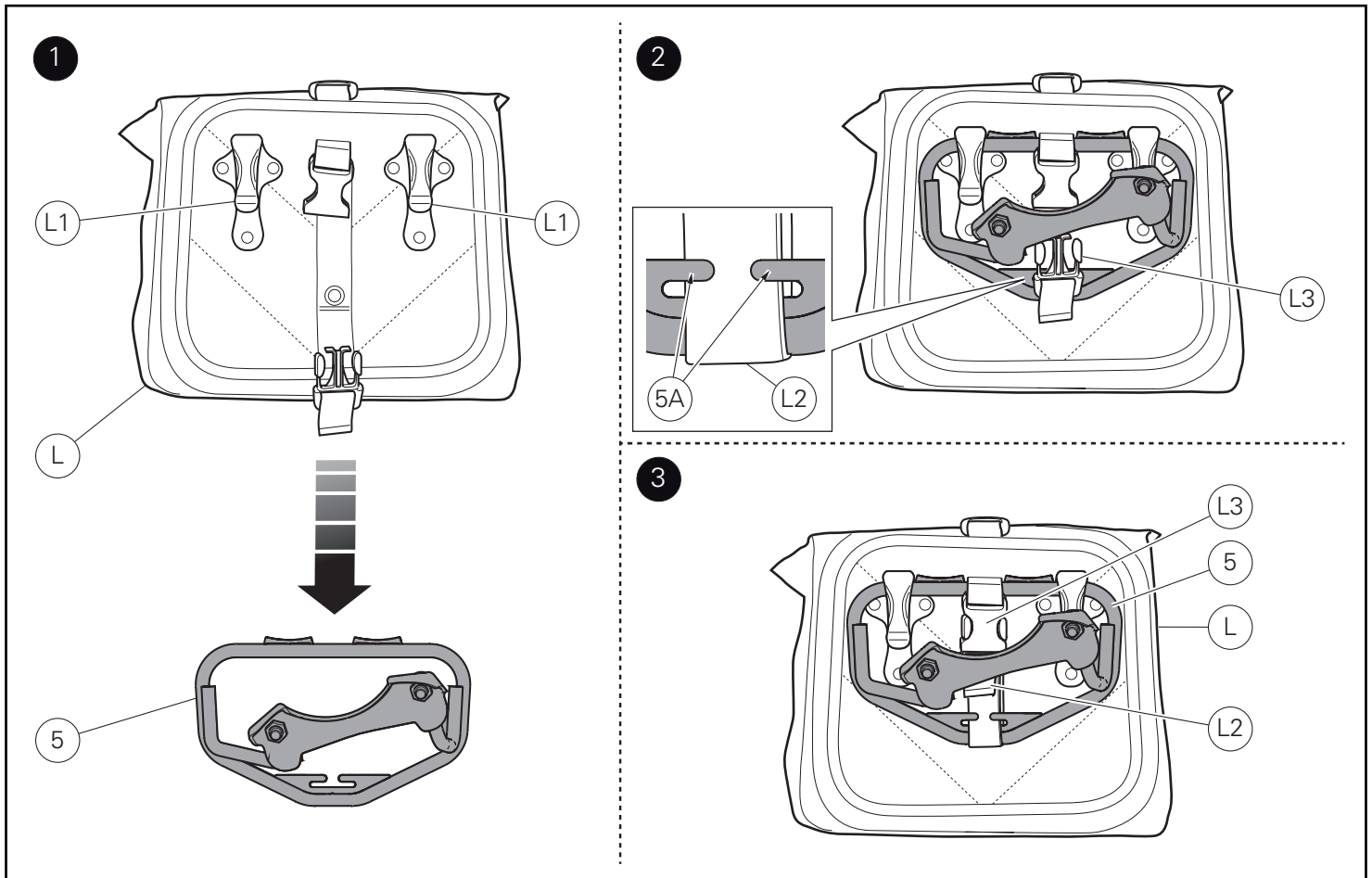

Pose valises latérales

Remarques

Sur le kit sous-cadre (96780741A) il est possible de poser le Kit valises latérales étanches URBAN ENDURO (96780751A) et le Kit valises latérales souples CLASSIC (96780761A).

Remarques

Chez un concessionnaire autorisé il est possible d'acheter le kit valises latérales étanches URBAN ENDURO (96780751A) et le Kit valises latérales souples CLASSIC (96780761A).

Remarques

Pour mieux comprendre la fixation de la sacoche au sous-cadre correspondant, on montre l'ensemble sous-cadre support sacoche retiré du motorcycle.

Appuyer les crochets (L1) de la sacoche droite (L) au sous-cadre droit (5) et exercer une pression vers le bas jusqu'à percevoir le « clac » d'accrochage, comme le montre la figure (1).
Faire passer la sangle (L2) de la valise à l'intérieur du sous-cadre et l'introduire dans les pattes inférieures (5A) ainsi que la figure (2) le montre.
Accrocher la boucle (L3) et tirer la sangle (L2) pour bien fixer la valise droite (L) au sous-cadre droit (5), comme la figure (3) le montre.
Répéter la même opération pour fixer la sacoche gauche (M) au sous-cadre gauche (2).

Montage der Seitenkoffer

Hinweis

Am Kit Halterahmen (96780741A) können das Kit wasserdichte Seitenkoffer URBAN ENDURO (96780751A) und das Kit weiche Seitenkoffer CLASSIC (96780761A) montiert werden.

Hinweis

Das Kit wasserdichte Seitenkoffer URBAN ENDURO (96780751A) und das Kit weiche Seitenkoffer CLASSIC (96780761A) sind bei einen Vertragshändler/autorisiertem Händler erhältlich.

Hinweis

Um die Verankerung der Tasche am entsprechenden Heckrahmen verständlicher darzustellen, wird die vom Motorrad abgenommene Einheit des Kofferhalterrahmens abgebildet.

Die Verankerungen (L1) der rechten Tasche (L) am rechten Heckrahmenteil (5) anlehnen und so lange nach unten drücken, bis das Einrasten zu hören ist, wie in Abbildung (1) gezeigt.
Den Riemen (L2) des Koffers durch den Halterahmen führen und in die unteren Rippen (5A) gemäß Abbildung (2) einfügen.
Die Schnalle (L3) einhaken und den Riemen (L2) ziehen, um den rechten Koffer (L) korrekt am rechten Halterahmen (5) gemäß Abbildung (3) zu befestigen.
Das Verfahren für das Einhängen der linken Tasche (M) am linken Heckrahmenteil (2) wiederholen.

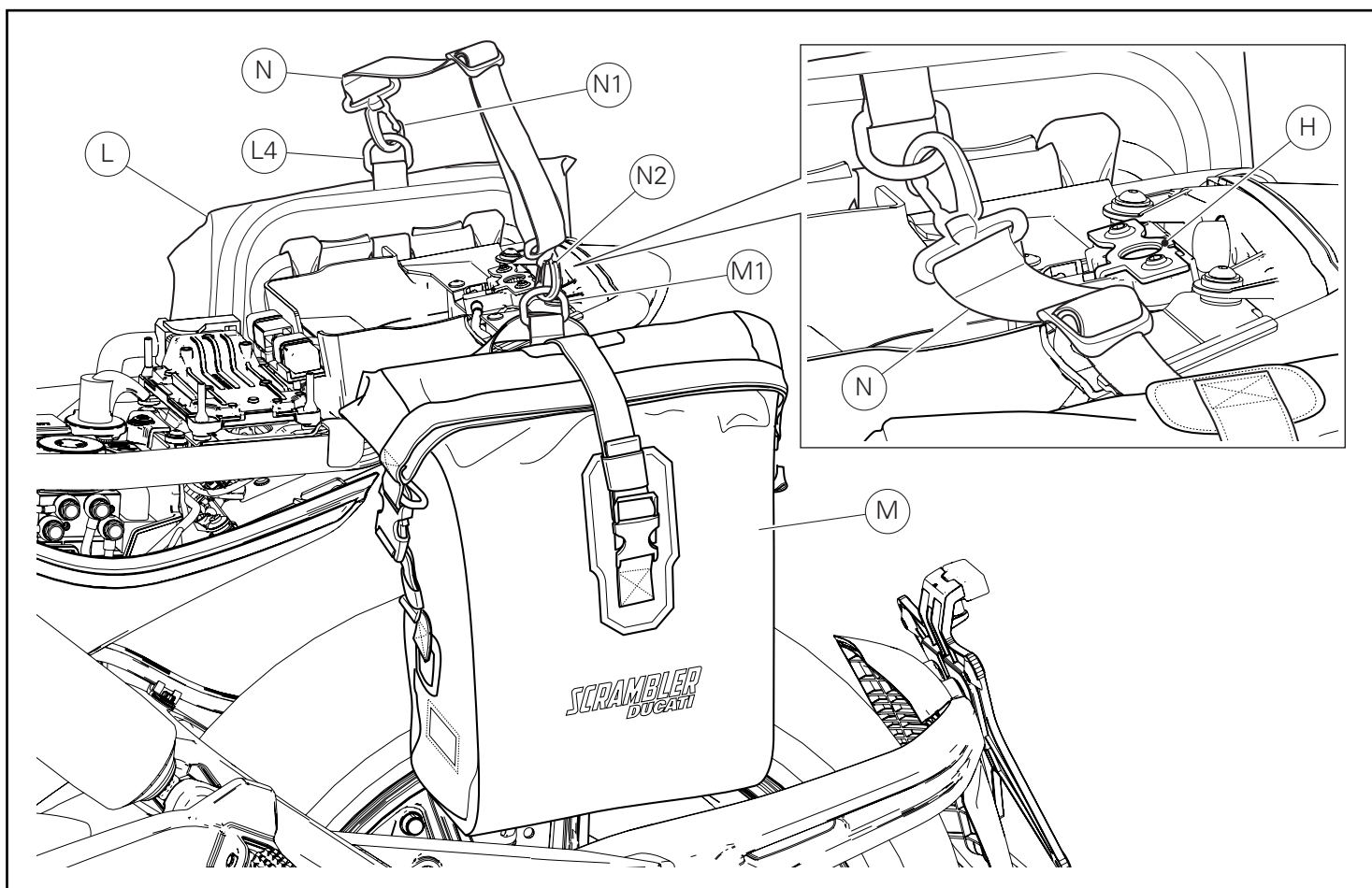

Après l'installation des deux sacoches il est nécessaire de les relier entre elles avec la courroie de sécurité (N).
 Accrocher la courroie de sécurité (N) à la bague (L4) sur la sacoche droite (L) à l'aide du mousqueton approprié (N1).
 Attacher l'autre extrémité de la courroie de sécurité (N) à la bague (M1) sur la sacoche gauche (M) à l'aide du mousqueton (N2).
 Tendre la courroie de sécurité (N).



Attention

La courroie de sécurité (N) ne doit pas couvrir le crochet (H) de fermeture de la selle.



Attention

Contrôler périodiquement l'intégrité de la courroie de sécurité (N) et des mousquetons correspondants (N1) et (N2).

Nach Montage der beiden Taschen müssen diese mit dem Sicherheitsriemen (N) untereinander verbunden werden.
 Den Sicherheitsriemen (N) mit der entsprechenden Schnalle (N1) am Ring (L4), der auf der rechten Tasche (L) vorhanden ist, einhaken.
 Das andere Ende des Sicherheitsriemens (N) mit der Schnalle (N2) am Ring (M1), der auf der linken Tasche (M) vorhanden ist, einhaken.
 Den Sicherheitsriemen (N) spannen.



Achtung

Der Sicherheitsriemen (N) darf die Verankerung (H) des Sitzbankverschlusses nicht abdecken.



Achtung

Regelmäßig den Sicherheitsriemen (N) und die jeweiligen Schnallen (N1) und (N2) auf Beschädigungen hin überprüfen.

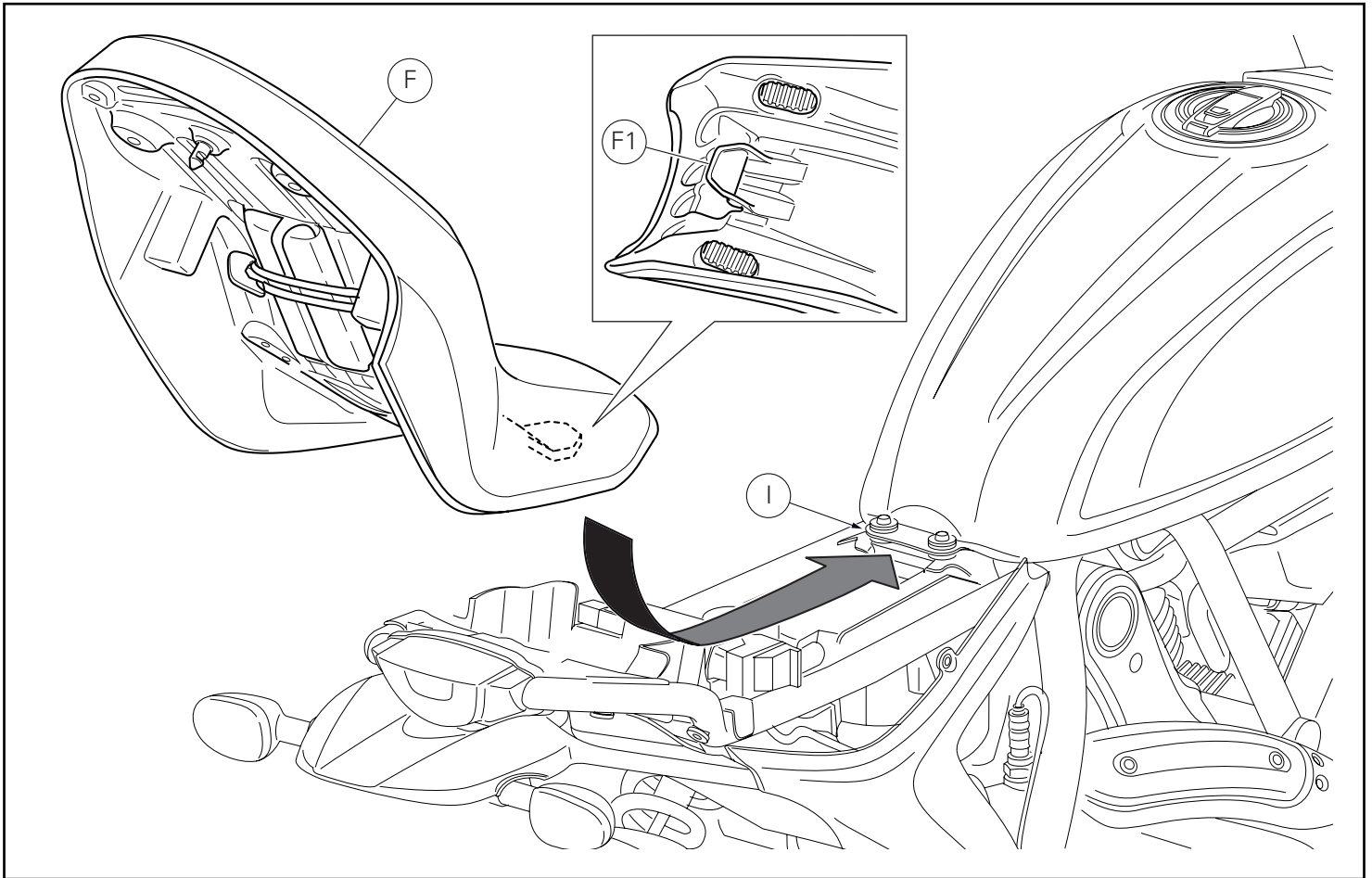

Vérifier que tous les éléments soient correctement placés et fixés dans le compartiment dessous de selle.
Insérer l'extrémité avant (F1) du fond de selle au-dessous du logement (I) du support du cadre.
Pousser sur l'extrémité arrière de la selle (F) jusqu'à ce que l'on entende le déclic du verrou de la serrure.
Vérifier que la selle soit solidement fixée au cadre et déposer la clé de la serrure.

⚠ Attention

Il est obligatoire de respecter les limitations de vitesse imposées par le pays où on est en train de circuler et de toute façon, il est interdit de dépasser les 130 Km/h avec les valises latérales installées sur la moto.

● Important

Une exposition continue et prolongée aux intempéries peut créer une décoloration mineure des tissus/matières.

⚠ Attention

Le poids maximum transportable des sacoches latérales est de 3 Kg pour la sacoche gauche et de 1,5 Kg pour la droite.
Au cas où on excéderait avec le poids conseillé on risque la rupture des valises mêmes.
Ceci peut avoir une influence négative sur la sécurité du pilote.

● Important

Lorsqu'on effectue le lavage du motorcycle, il est nécessaire de déposer les valises latérales.

Sicherstellen, dass alle Elemente korrekt angeordnet und im Sitzbankfach befestigt sind.

Das vordere Endstück (F1) des Sitzbankbodens unter den Sitz (I) des Rahmenträgers einfügen.

Auf den hinteren Bereich der Sitzbank (F) drücken, bis das Einrasten der Schlossverriegelung zu hören ist.

Sicherstellen, dass die Sitzbank fest am Rahmen befestigt ist, dann den Schlüssel aus dem Schloss ziehen.

⚠ Achtung

Es ist Pflicht, die geltenden Geschwindigkeitsbeschränkungen des Landes, im dem man fährt, einzuhalten und es ist auf jeden Fall verboten, mit den am Motorrad montierten Seitenkoffern über 130 Km/h zu fahren.

● Wichtig

Die ständige und dauernde Aussetzung der Wetterlage könnte minimale Färbänderungen der Stoffe/Materialien verursachen.

⚠ Achtung

Das in den Taschen transportierbare Höchstgewicht beträgt 3 kg für die linke Tasche und 1,5 kg für die rechte Tasche.
Sollte das empfohlene Gewicht überschritten werden, könnte es zum Riss der Koffer führen.
Dadurch kann die Fahrersicherheit beeinträchtigt werden.

● Wichtig

Vor der Wäsche des Motorrads müssen die Seitenkoffer abgenommen werden.

REMARQUES / HINWEIS

A series of horizontal dotted lines for writing notes.

Conjunto de subchassis para bolsas laterais macias Soft side pannier subframe kit



Símbolos

Para uma leitura rápida e racional, foram utilizados símbolos que evidenciam situações de máxima atenção, conselhos práticos ou simples informações. Preste muita atenção ao significado dos símbolos, pois a sua função é a de evitar a repetição de conceitos técnicos ou de avisos de segurança. Portanto, os símbolos devem ser considerados como verdadeiros "lembretes". Consulte esta página sempre que tiver dúvidas acerca do seu significado.



Atenção

O não cumprimento das instruções mostradas pode criar uma situação de perigo e causar graves lesões pessoais e até mesmo a morte.



Importante

Indica a possibilidade de causar danos ao veículo e/ou aos seus componentes se as instruções mostradas não forem executadas.



Notas

Fornecer informações úteis sobre a operação em curso.

Referências

Os detalhes evidenciados em cinza e com referência numérica (Ex. ①) representam o acessório a ser instalado e os eventuais componentes de montagem fornecidos como kit.

Os detalhes com referência alfabética (Ex. A) representam os componentes originais presentes na moto.

Todas as indicações direita ou esquerda, referem-se ao sentido de marcha da moto.

Advertências gerais



Atenção

As operações mostradas nas páginas a seguir, se não forem executadas com boa técnica, podem prejudicar a segurança do condutor.



Atenção

As operações mostradas nas páginas a seguir, se não forem executadas com boa técnica, podem prejudicar a segurança do condutor.



Notas

Documentação necessária para executar a montagem do Conjunto: MANUAL DE OFICINA, relativo ao modelo de moto em sua posse.



Notas

Caso seja necessária a substituição de um componente do conjunto, consulte o quadro de peças de reposição em anexo.

Symbols

To allow quick and easy consultation, this manual uses graphic symbols to highlight situations in which maximum care is required, as well as practical advice or information.

Pay attention to the meaning of the symbols since they serve to avoid repeating technical concepts or safety warnings throughout the text. The symbols should therefore be seen as real reminders. Please refer to this page whenever in doubt as to their meaning.



Warning

Failure to follow these instructions might give rise to a dangerous situation and provoke severe personal injuries or even death.



Caution

Failure to follow these instructions might cause damages to the vehicle and/or its components.



Notes

Useful information on the procedure being described.

References

Parts highlighted in grey and with a numeric reference (Example ①) are the accessory to be installed and any assembly components supplied with the kit.

Parts with an alphabetic reference (Example A) are the original components fitted on the vehicle.

Any right- or left-hand indication refers to the vehicle direction of travel.

General notes



Warning

Carefully perform the operations on the following pages since they might negatively affect rider safety.



Warning

Carefully perform the operations on the following pages since they might negatively affect rider safety.



Notes

The following documents are necessary for assembling the Kit: WORKSHOP MANUAL of your bike model.



Notes

Should it be necessary to change any kit parts, please refer to the attached spare part table.

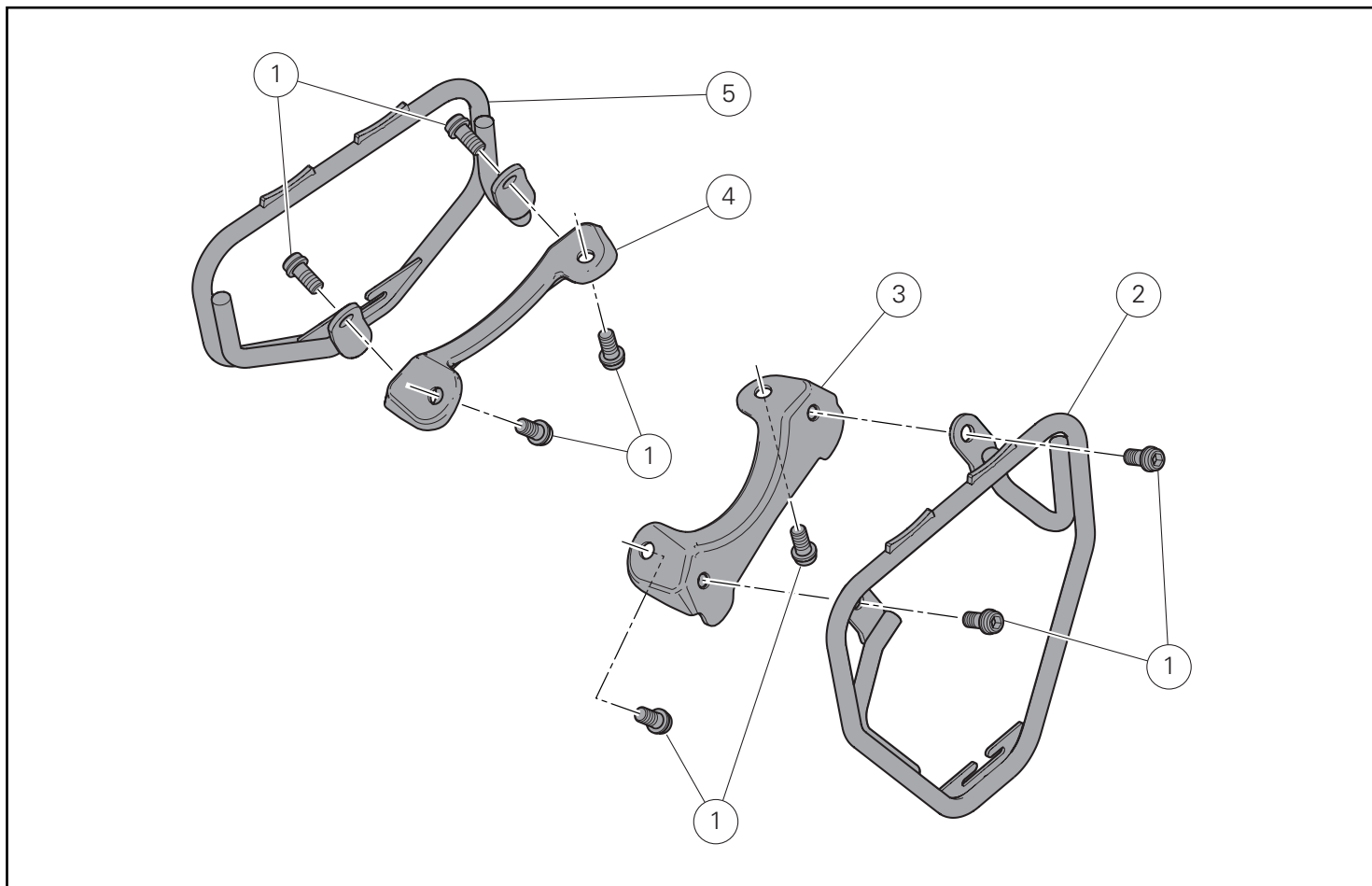

Pos.	Descrição	Description
1	Parafuso de cabeça cilíndrica flangeada com sextavado interno M8x16	TCEIF screw M8x16
2	Subchassi de suporte das bolsas esquerdo	LH pannier support subframe
3	Placa de suporte das bolsas esquerda	LH pannier support plate
4	Placa de suporte das bolsas direita	RH pannier support plate
5	Subchassi de suporte das bolsas direito	RH pannier support subframe

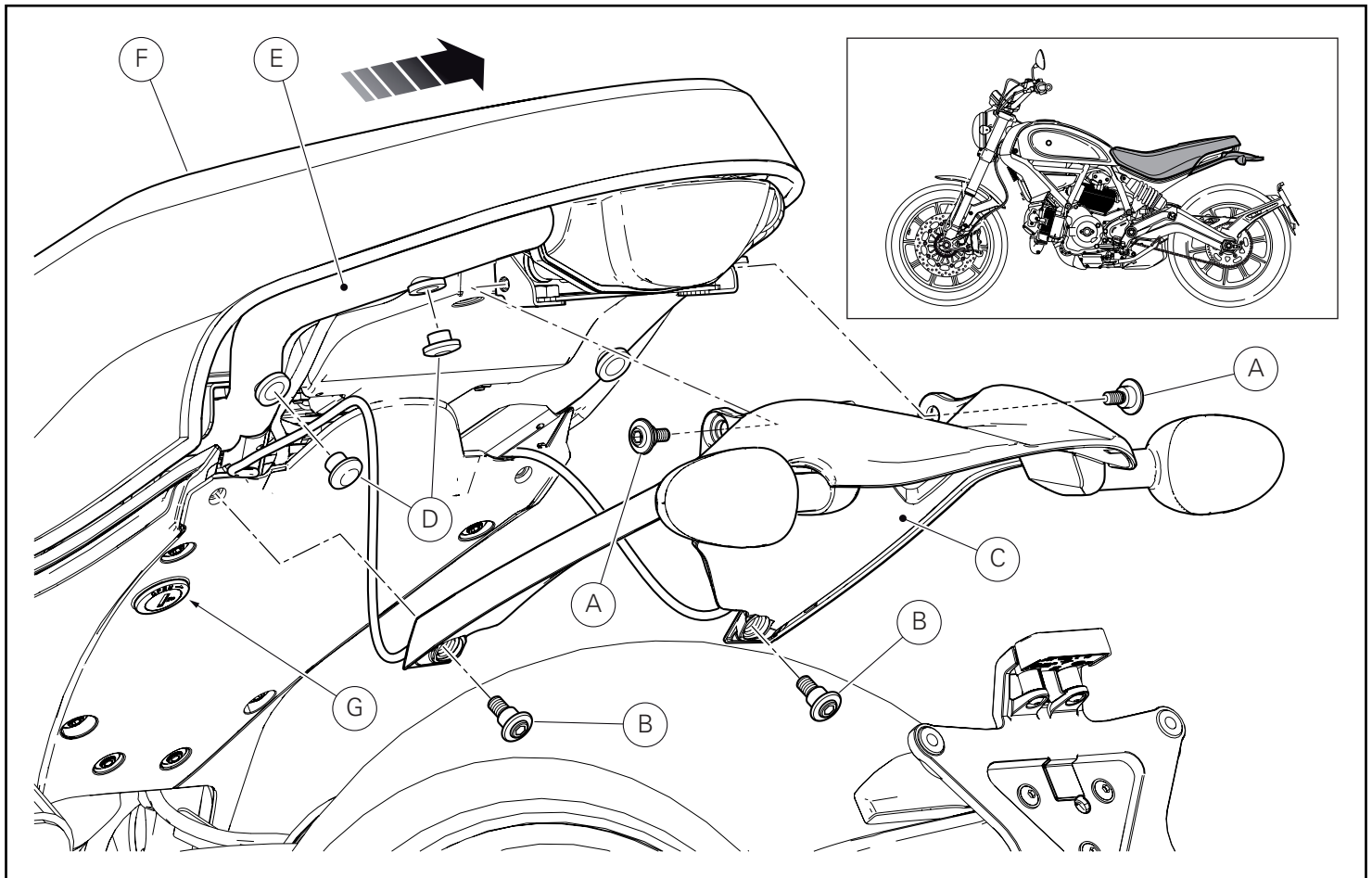

Desmontagem dos componentes originais

Introduza a chave na fechadura (G), gire-a no sentido horário e simultaneamente pressione para baixo perto do ferrolho para facilitar o desengate do pino.

Retire o assento (F) dos retentores dianteiros, puxando-o para trás. Desatarraxe os 2 parafusos superiores (A) e os 2 parafusos inferiores (B) de fixação do grupo proteção traseira (C).

Retire e suporte adequadamente o grupo proteção traseira (C), prestando atenção para não danificar as cablagens dos indicadores de direção.

Remova os 4 tampões (D) do chassi (E).

Removing the original components

Insert the key in the lock (G), turn the key clockwise and simultaneously press downward in the area of the latch to release the pin.

Pull the seat (F) backwards to release it from the front retainers. Undo the 2 upper screws (A) and the 2 lower screws (B) securing rear guard assembly (C).

Slide rear guard assembly (C) out and properly support it paying attention not to damage turn indicator wiring.

Remove 4 plugs (D) from frame (E).

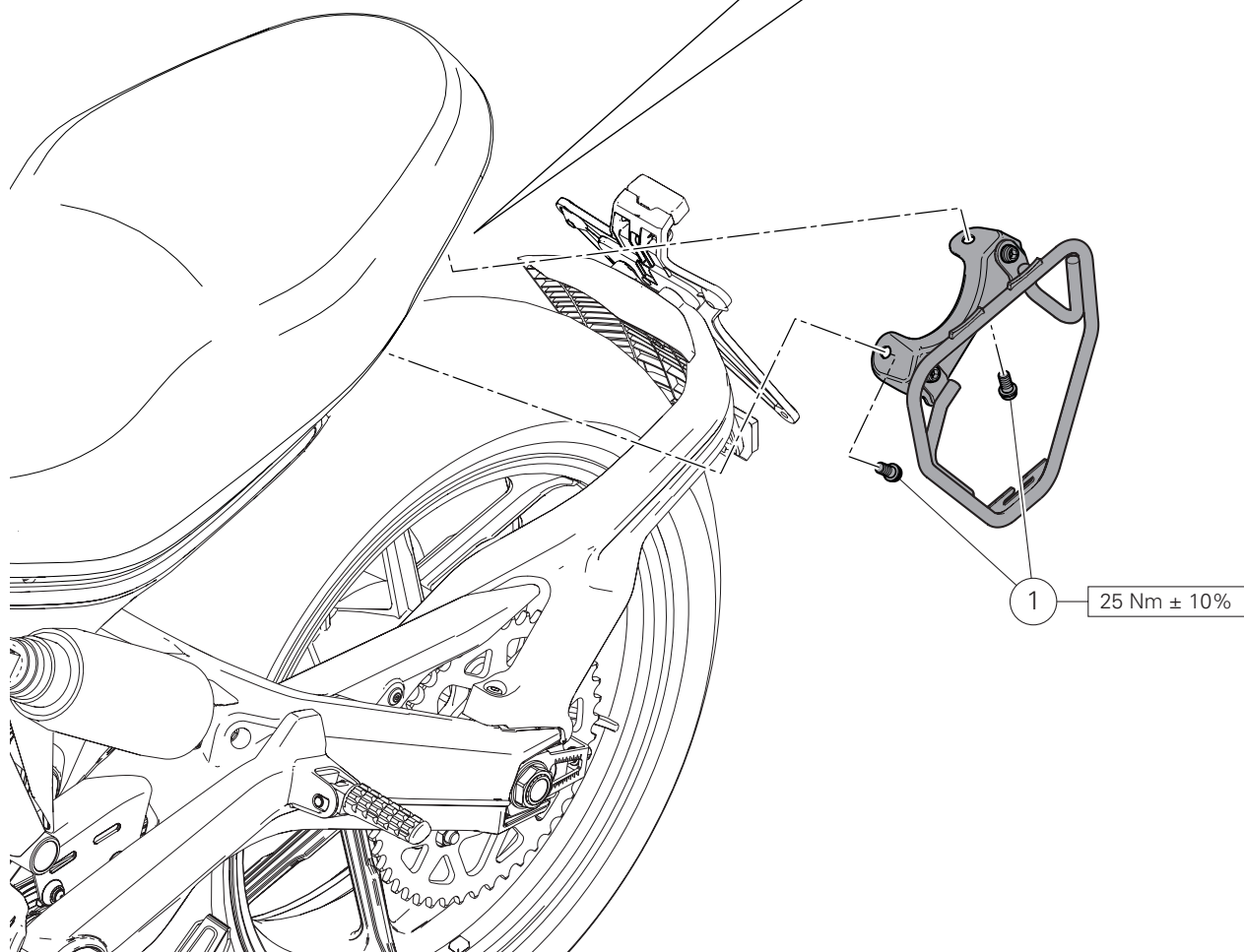
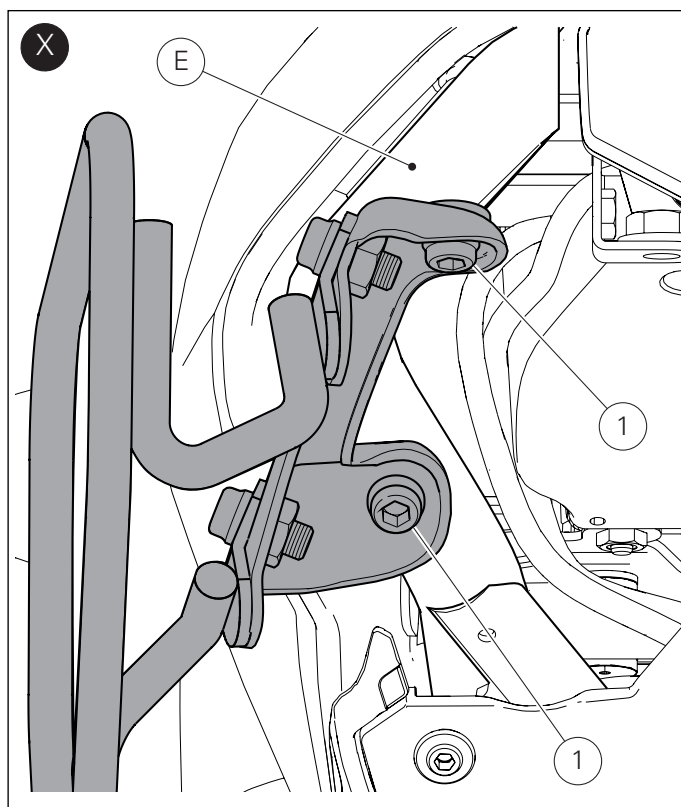
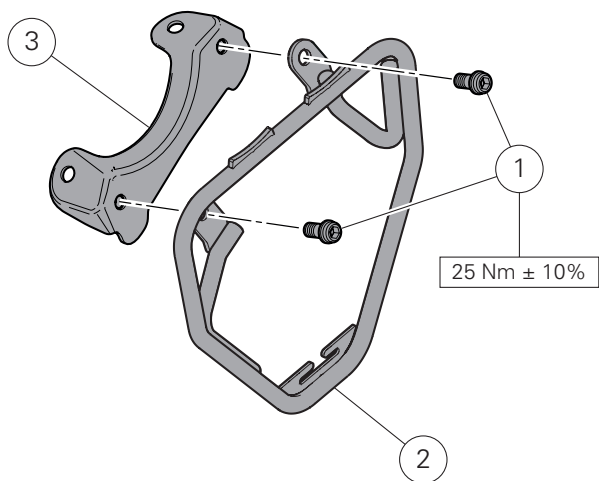

Montagem dos componentes



Importante

Verifique, antes da montagem, se todos os componentes estão limpos e em perfeito estado.

Adote todas as precauções necessárias para evitar danificar qualquer peça com a qual deve trabalhar.

Pré-montagem do grupo subchassi esquerdo

Monte previamente a placa de suporte das bolsas esquerda (3) no subchassi esquerdo (2), introduzindo os 2 parafusos (1).

Aperte os 2 parafusos (1) ao binário indicado.

Montagem do grupo subchassi esquerdo

Fixe o grupo subchassi esquerdo no chassi (E), introduzindo os 2 parafusos (1), como indicado na figura (X).

Aperte os 2 parafusos (1) ao binário indicado.

Kit installation



Caution

Check that all components are clean and in perfect condition before installation.

Adopt any precaution necessary to avoid damages to any part of the motorcycle you are working on.

LH subframe unit pre-assembly

Pre-assemble LH pannier support plate (3) on LH subframe (2) by starting the 2 screws (1).

Tighten the 2 screws (1) to the specified torque.

LH subframe unit assembly

Secure LH subframe unit to frame (E) by starting the 2 screws (1), as shown in figure (X).

Tighten the 2 screws (1) to the specified torque.

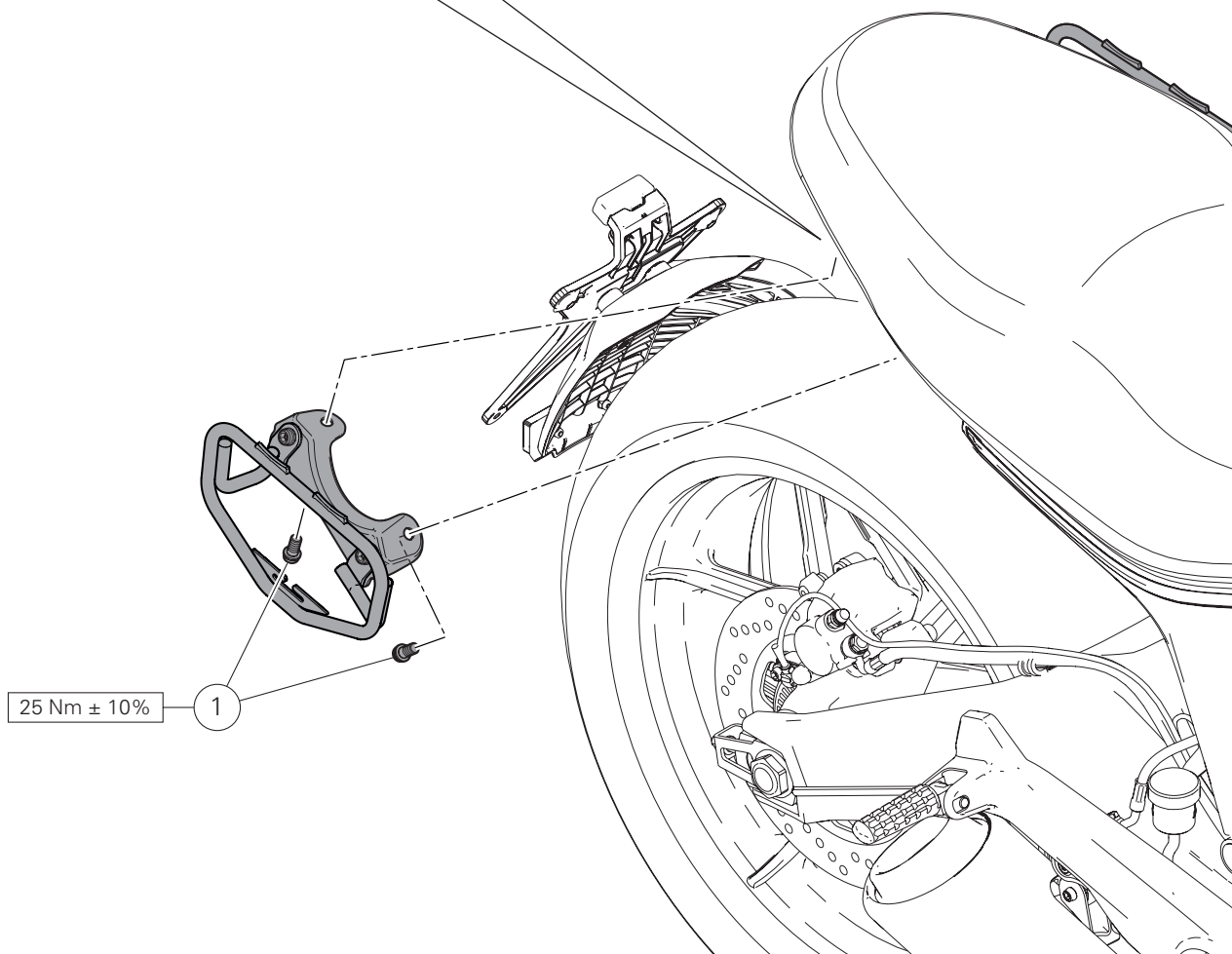
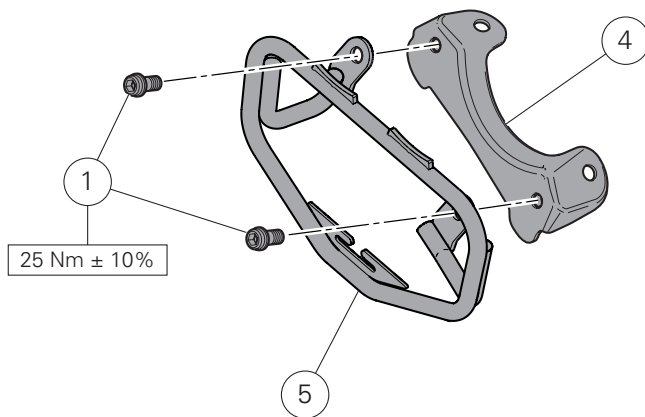
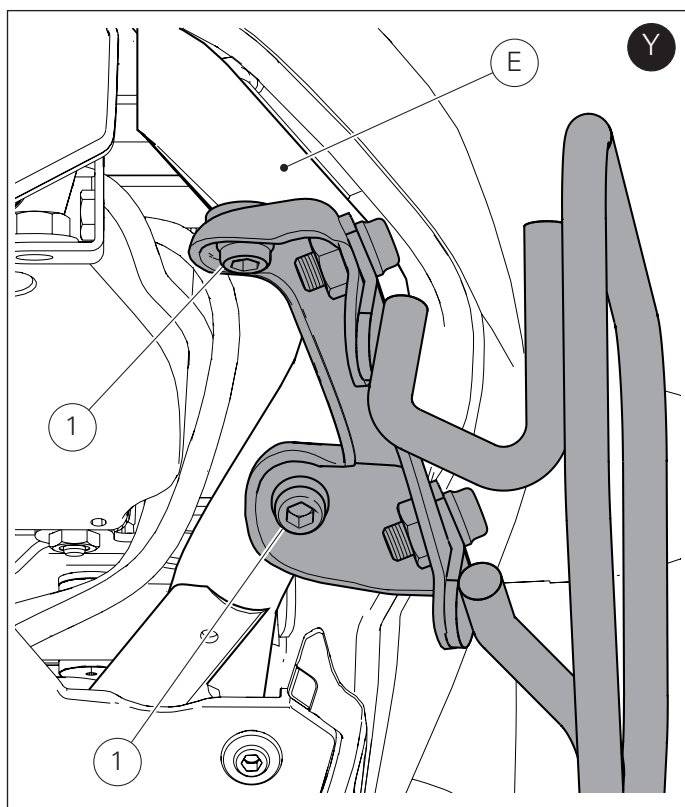

Pré-montagem do grupo subchassi direito

Monte previamente a placa de suporte das bolsas direita (4) no subchassi direito (5), introduzindo os 2 parafusos (1).
Aperte os 2 parafusos (1) ao binário indicado.

Montagem do grupo subchassi direito

Fixe o grupo subchassi direito no chassi (E), introduzindo os 2 parafusos (1), como indicado na figura (Y).
Aperte os 2 parafusos (1) ao binário indicado.

RH subframe unit pre-assembly

Pre-assemble RH pannier support plate (4) on RH subframe (5) by starting the 2 screws (1).
Tighten the 2 screws (1) to the specified torque.

RH subframe unit assembly

Secure RH subframe unit to frame (E) by starting the 2 screws (1), as shown in figure (Y).
Tighten the 2 screws (1) to the specified torque.

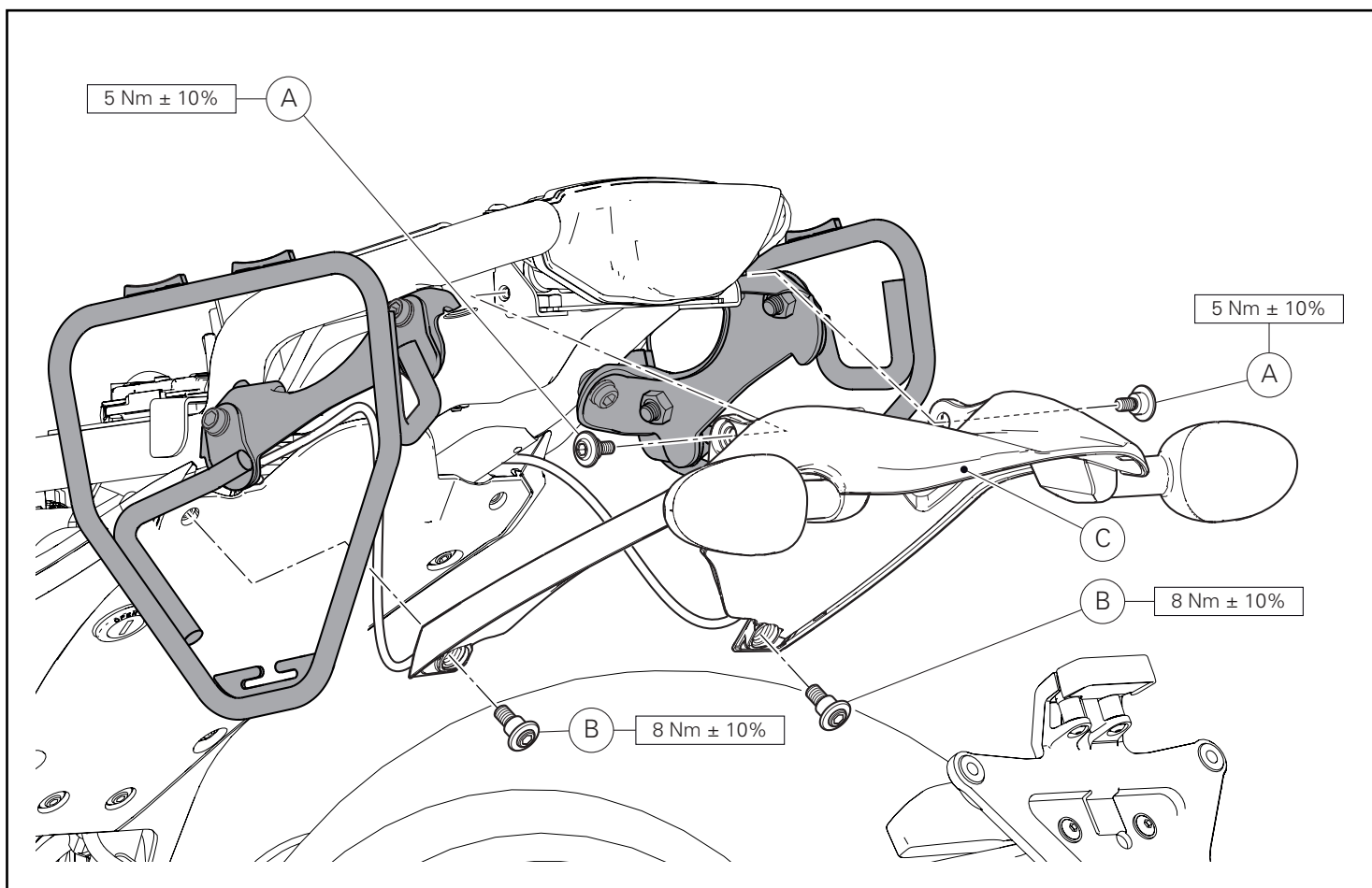

Posicione o grupo proteção traseira (C) no chassi e introduza os 2 parafusos superiores (A).

Introduza os 2 parafusos inferiores (B) de fixação do grupo proteção traseira (C) no chassi.

Fixe o grupo proteção traseira (C), apertando os 2 parafusos superiores (A) e os 2 parafusos inferiores (B) ao binário indicado.

Position rear guard assembly (C) on frame and start the 2 upper screws (A).

Start the 2 lower screws (B) that fasten rear guard assembly (C) to frame.

Fix rear guard assembly (C) tightening the 2 upper screws (A) and the 2 lower screws (B) to the specified torque.

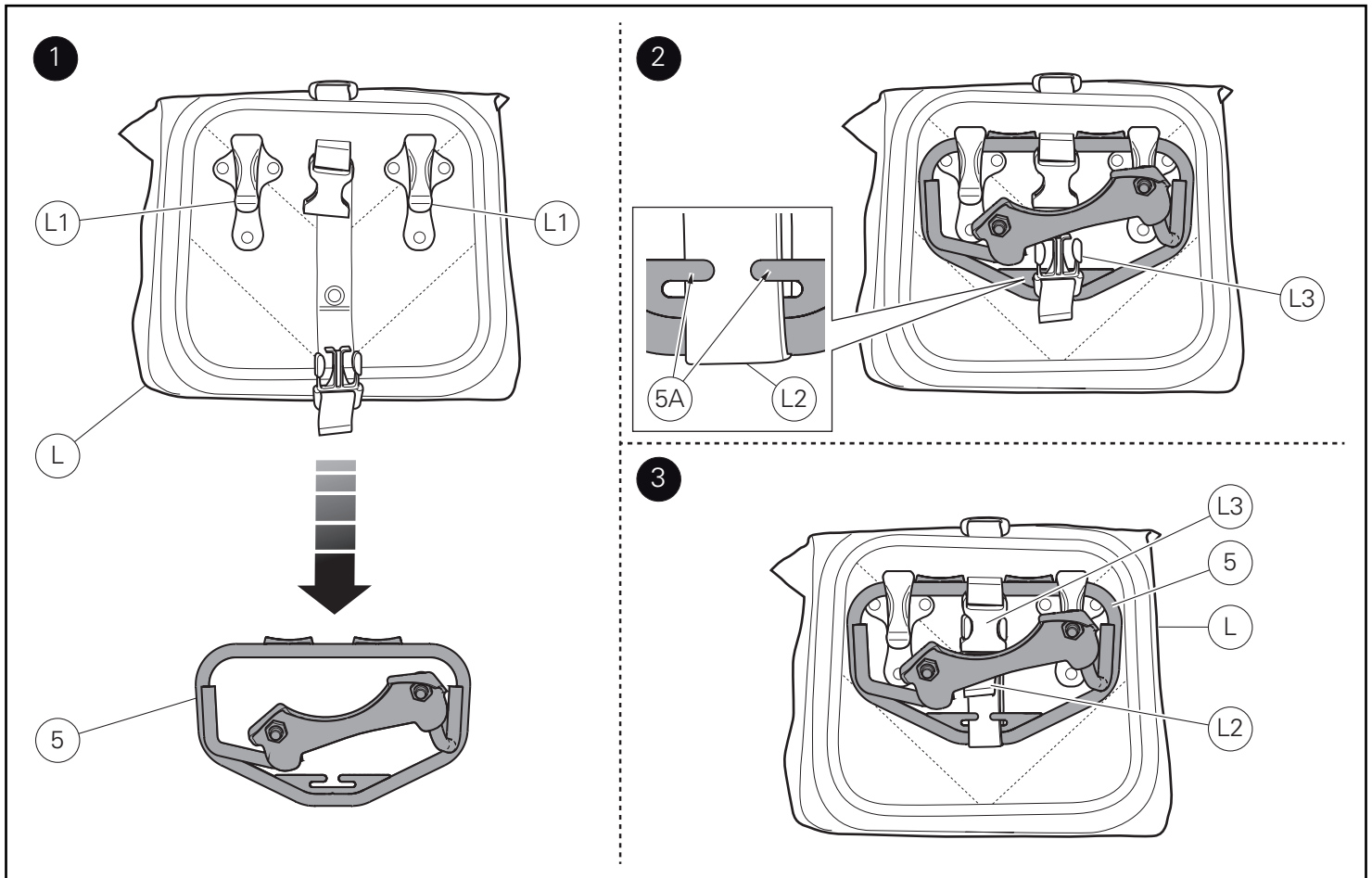

Montagem das bolsas laterais



Notas

No conjunto de subchassi (96780741A) é possível montar o Conjunto de bolsas laterais herméticas URBAN ENDURO (96780751A) e o Conjunto de bolsas laterais macias CLASSIC (96780761A).



Notas

É possível adquirir Conjunto de bolsas laterais herméticas URBAN ENDURO (96780751A) e o Conjunto de bolsas laterais macias CLASSIC (96780761A) junto a um concessionário/dealer autorizado.



Notas

Para entender melhor o engate da bolsa no respetivo subchassi, o grupo do subchassi de suporte da bolsa é representado desmontado da moto.

Apoie os engates (L1) da bolsa direita (L) no subchassi direito (5) e empurre para baixo até ouvir o clique, conforme o mostrado na figura (1).

Faça a cinta (L2) da bolsa passar por dentro do subchassi e insira-a nas aletas inferiores (5A), como o mostrado na figura (2).

Engate a fivela (L3) e puxe a cinta (L2) para fixar corretamente a bolsa direita (L) no subchassi direito (5), como o mostrado na figura (3).

Repita a mesma operação para engatar a bolsa esquerda (M) no subchassi esquerdo (2).

Assembling the side panniers



Notes

On the subframe kit (96780741A) it is possible to assemble the URBAN ENDURO waterproof side pannier kit (96780751A) and the CLASSIC side soft bag kit (96780761A).



Notes

The URBAN ENDURO waterproof side pannier kit (96780751A) and the CLASSIC side soft bag kit (96780761A) can be purchased at an authorized dealer.



Notes

To better understand pannier securing on relevant subframe, pannier support subframe unit is represented removed from the motorcycle.

Lay right pannier (L) retainers (L1) onto right subframe (5) and push down until hearing a click, as shown in figure (1).

Drive strap (L2) of the pannier inside the subframe and fit it in the lower tabs (5A) as shown in figure (2).

Close buckle (L3) and pull strap (L2) to correctly secure RH pannier (L) to RH subframe (5), as shown in figure (3).

Repeat the same procedure to fasten left pannier (M) to left subframe (2).

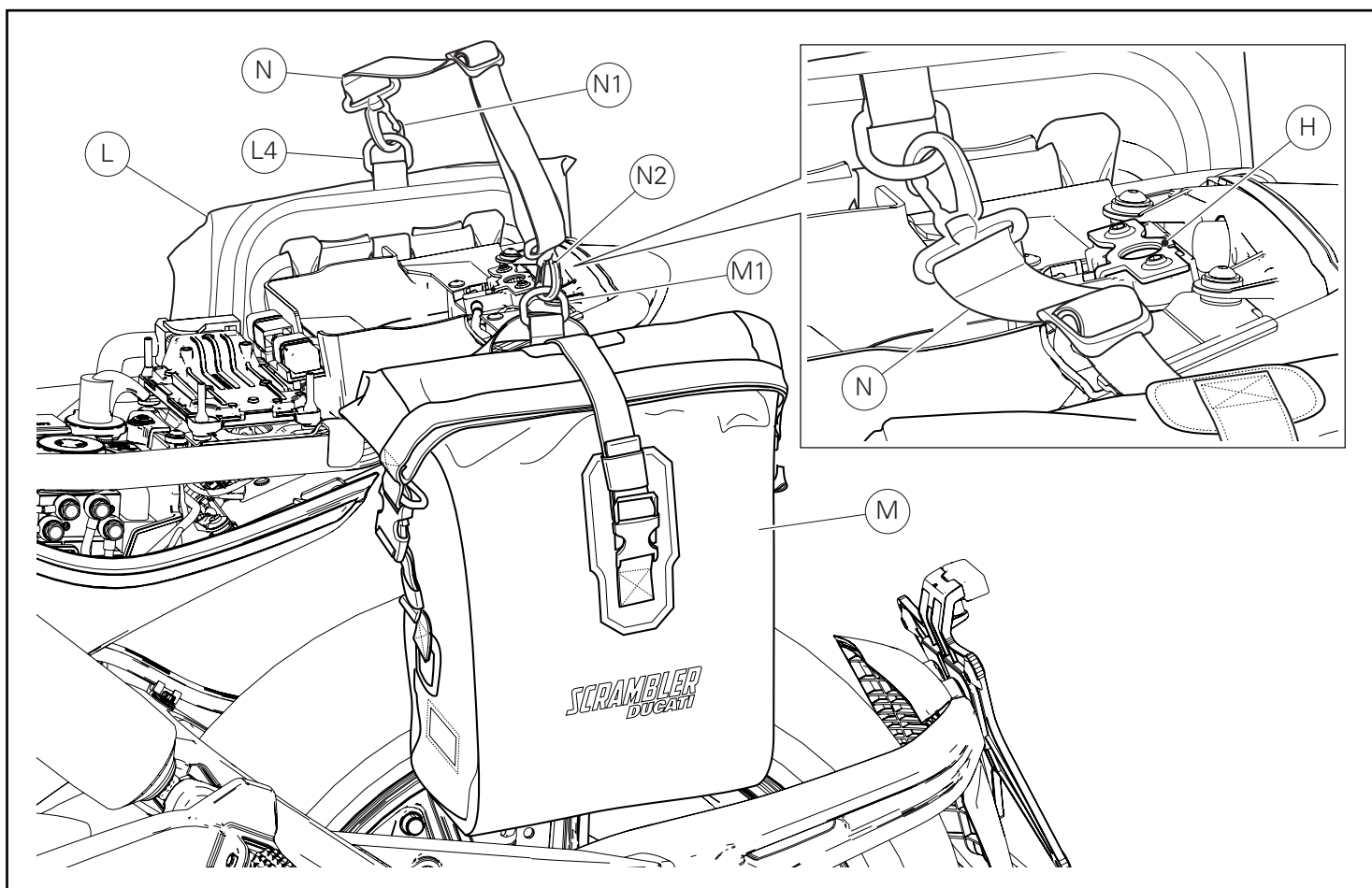

Após ter montado ambas as bolsas, é preciso atar até-las entre si com a tira de segurança (N).

Engate a tira de segurança (N) com o específico mosquetão (N1) ao anel (L4), presente na bolsa direita (L).

Engate a outra extremidade da tira de segurança (N) ao anel (M1), presente na bolsa esquerda (M), utilizando o mosquetão (N2).

Estique a tira de segurança (N).

⚠ Atenção

A tira de segurança (N) não deve cobrir o engate (H) do fecho do assento.

⚠ Atenção

Controle periodicamente a integridade da tira de segurança (N) e dos respetivos mosquetões (N1) e (N2).

After fitting both panniers, fasten them to one another using safety belt (N).

Use the suitable snap hook (N1) to fasten safety belt (N) to ring (L4) on right pannier (L).

Fasten the other end of safety belt (N) to ring (M1) on left pannier (M), using snap hook (N2).

Tension safety belt (N).

⚠ Warning

Safety belt (N) must not cover hook (H) of seat closing.

⚠ Warning

Periodically check safety belt (N) and relevant snap hooks (N1) and (N2) conditions.

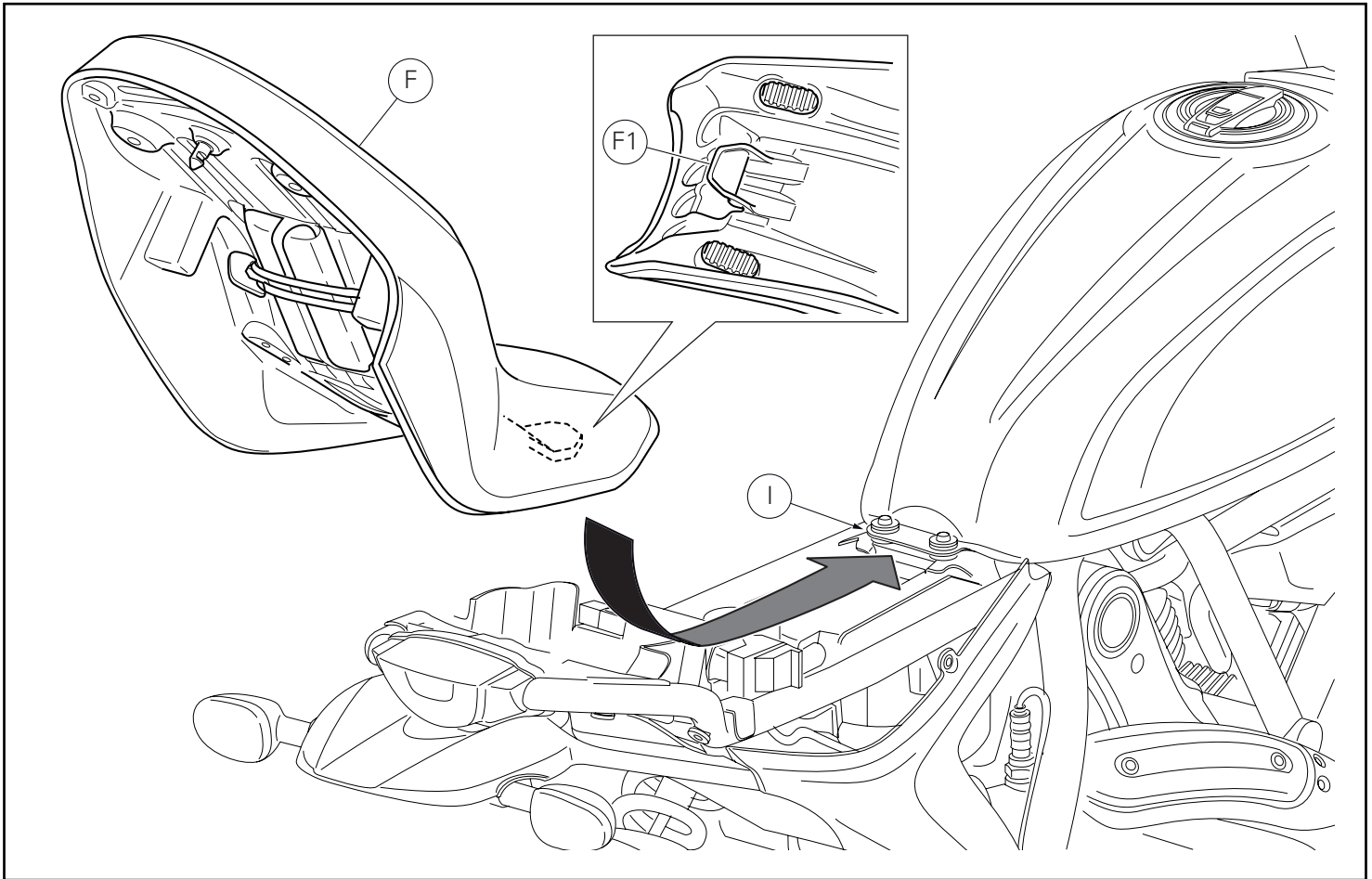

Certifique-se de que todos os elementos estejam corretamente dispostos e fixados no compartimento debaixo do assento. Insira a extremidade dianteira (F1) do fundo do assento debaixo da sede (I) do suporte do chassi. Empurre na extremidade traseira do assento (F) até ouvir o disparo do ferrolho da fechadura. Certifique-se de que o assento esteja fixado firmemente ao chassi e remova a chave da fechadura.

⚠️ Atenção

É obrigatório respeitar os limites de velocidade impostos pelo país onde circula com a moto e, de qualquer maneira, é proibido ultrapassar os 130 Km/h com as bolsas laterais montadas na moto.

● Importante

A contínua e prolongada exposição aos agentes atmosféricos pode causar mínimas ou sensíveis mudanças na cor dos tecidos/materiais.

⚠️ Atenção

O peso máximo transportável pelas bolsas laterais é de 3 Kg para a bolsa esquerda e 1,5 Kg para a bolsa direita. Se exceder o peso aconselhado, risca-se o rompimento das bolsas. Isto pode influenciar negativamente a segurança do condutor.

● Importante

Quando efetuar a lavagem da moto, será necessário remover as bolsas laterais.

Make sure that all parts are correctly arranged and secured in the compartment under the seat. Slide the front end (F1) of the seat bottom underneath the seat (I) of the frame support. Press on seat (F) rear end until locking latch snaps. Make sure that the seat is firmly secured to the frame and remove the key from the lock.

⚠️ Warning

Always respect the speed limits in force in the country where bike is ridden and, anyway, do not exceed 130 Km/h with the side panniers installed on bike.

● Caution

Continuous and prolonged exposure to weather may create minor discoloration in the fabrics/materials.

⚠️ Warning

Side pannier maximum loading capacity is 3 Kg for left pannier and 1.5 for right pannier. Should this weight be exceeded, panniers could break. This can affect rider's safety.

● Caution

When washing the bike, always remove side panniers.

NOTAS / NOTES

Area for notes with horizontal dotted lines.

Kit subchasis bolsas laterales suaves ソフトサイドバッグサブフレームキット



Símbolos

Para una lectura rápida y racional se han empleado símbolos que evidencian situaciones de máxima atención, consejos prácticos o simples informaciones. Prestar mucha atención al significado de los símbolos porque su función consiste en omitir la repetición de conceptos técnicos o advertencias de seguridad. Los símbolos deben considerarse como verdaderos "apuntes". Consultar esta página cada vez que se tengan dudas sobre su significado.



Atención

El incumplimiento de las instrucciones indicadas puede crear una situación de peligro y ocasionar graves lesiones e incluso la muerte.



Importante

Indica la posibilidad de provocar un daño al vehículo y/o a sus componentes si no se siguen las instrucciones indicadas.



Notas

Suministra útiles informaciones sobre la operación en curso.

Referencias

Las partes resaltadas en gris y la referencia numérica (Por ej. ①) representan el accesorio que se debe instalar y los eventuales componentes de montaje suministrados en el kit.

Las partes con referencia alfabética (Por ej. (A)) representan los componentes originales presentes en la motocicleta.

Todas las indicaciones derecha o izquierda se refieren al sentido de marcha de la motocicleta.

Advertencias generales



Atención

Las operaciones descritas en las siguientes páginas deben realizarse correctamente para no perjudicar la seguridad del piloto.



Atención

Las operaciones descritas en las siguientes páginas deben realizarse correctamente para no perjudicar la seguridad del piloto.



Notas

La documentación necesaria para realizar el montaje del Kit es el: MANUAL DE TALLER, relativo al modelo de moto en vuestro poder.



Notas

Si fuera necesario sustituir un componente del kit, consultar la tabla de recambios adjunta.

シンボル

素早くかつ合理的に読み進めることができるように、本マニュアルではいくつかのシンボルを導入し、最大限の注意を払う必要がある状況や、推奨事項、または一般情報を明確にしています。技術的概念や安全に関する警告を繰り返し記載する必要がないように機能しているので、各シンボルの意味に十分注意してください。シンボルは、実際上の“覚え書き”であると考えてください。シンボルなどの意味がわからなくなったり疑問に思う場合は、必ずこのページで調べるようにしてください。



注記

この説明書に従わずに使用すると危険な状況を招き、重大なけが、あるいは死をももたらす原因となることがあります。



重要

この説明書に従わずに使用すると、車体及び/ 又はその部品に損害を招く可能性があります



参考

操作中の内容に関する有用な情報を掲載しています。

参照

灰色で表示する部品、および参照番号 (Es. ①) で表示する部品は、キットに付属する取り付け部品および組み立て部品を示します。

参照アルファベット (Es. (A)) で表示する部品は、車両に付属するオリジナル部品を示します。

すべての右及び左の指示は車体の進行方向を向いたものです。

一般警告事項



警告

以下のページに記載されている作業が規定通りに実施されないと、ライダーの安全性を脅かすおそれがあります。



警告

以下のページに記載されている作業が規定通りに実施されないと、ライダーの安全性を脅かすおそれがあります。



参考

キットの取り付けに必要な資料：お手持ちの車両モデルに対応するワークショップマニュアル。



参考

キットの部品を交換する必要がある場合は、添付のスペアパーツ表を参照してください。

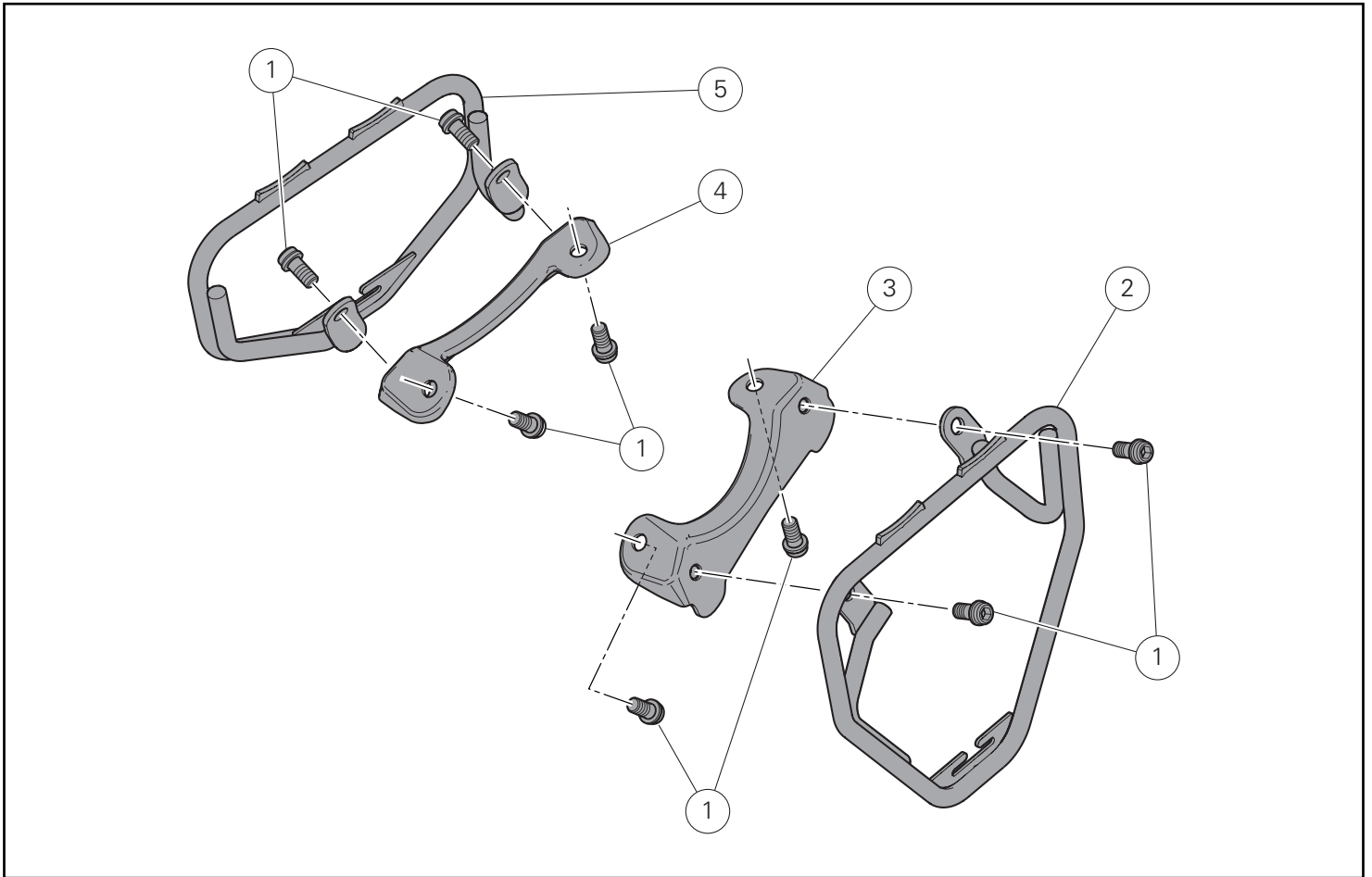

Pos.	Denominacion	説明
1	Tornillo especial TCEIF M8x16	TCEIF M8x16スクリュー
2	Subchasis soporte bolsas izquierdo	左バッグマウントサブフレーム
3	Placa soporte bolsas izquierda	左バッグマウントプレート
4	Placa soporte bolsas derecha	右バッグマウントプレート
5	Subchasis soporte bolsas derecho	右バッグマウントサブフレーム

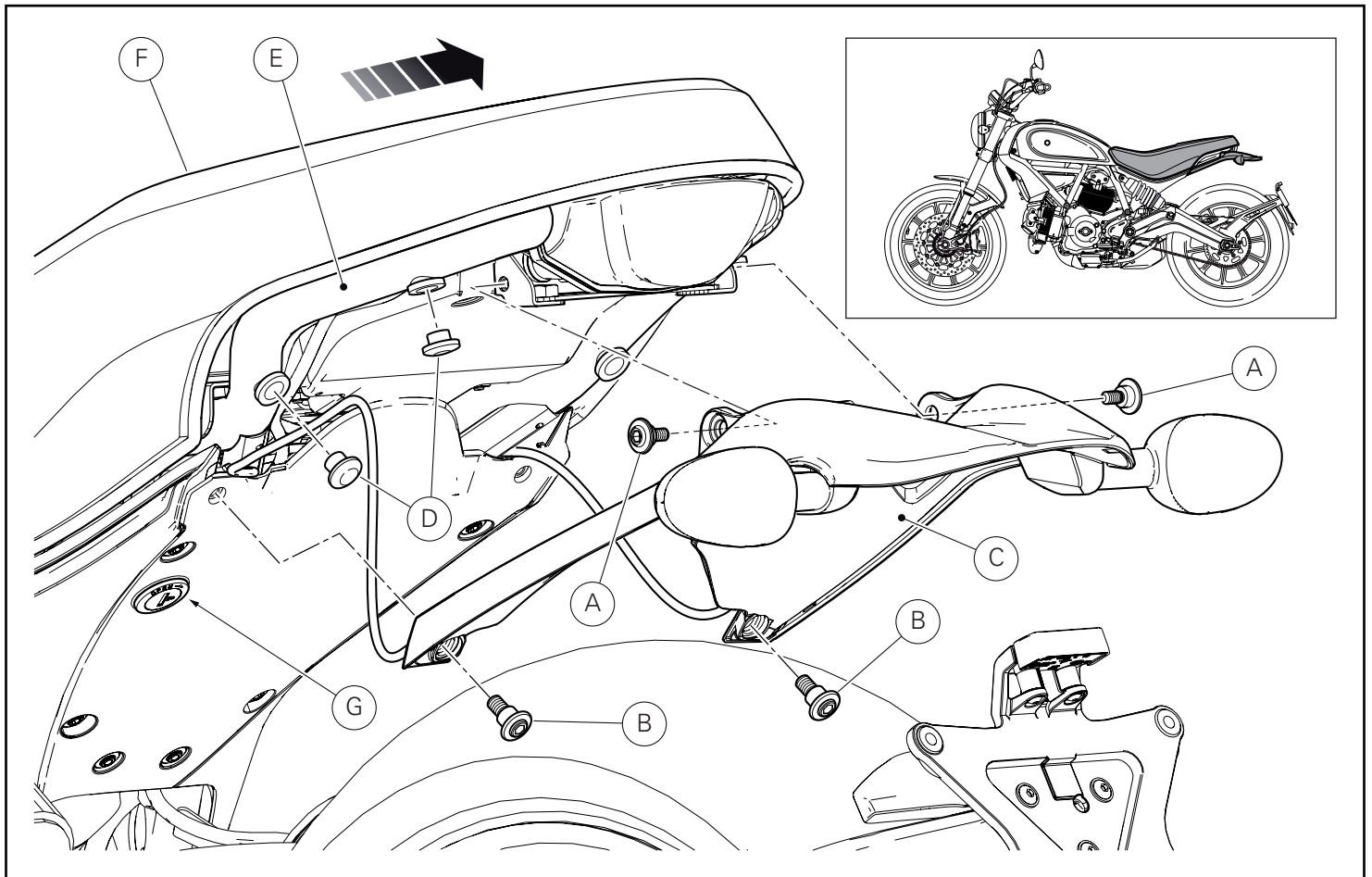

Desmontaje componentes originales

Introducir la llave en la cerradura (G), girarla en el sentido de las agujas del reloj y contemporáneamente presionar hacia abajo cerca del pestillo para facilitar el desenganche del perno.

Extraer el asiento (F) de los seguros delanteros, tirándolo hacia atrás.

Desatornillar los 2 tornillos superiores (A) y los 2 tornillos inferiores (B) que fijan el grupo protector trasero (C).

Extraer y sostener de manera adecuada el grupo protección trasero (C), prestando atención de no dañar los cables de los indicadores de dirección.

Quitar los cuatro tapones (D) del bastidor (E).

オリジナル部品の取り外し

キーを鍵穴 (G) に差し込み、時計周りに回します。同時に、ピンを外しやすくするために掛け金の近くを下に押し下げます。フロントストッパーからシート (F) を後ろ側へ引き出します。リアパネルユニット (C) の上側を固定している 2 本のスクリュー (A) および下側を固定している 2 本のスクリュー (B) を緩めて外します。

ターンインジケーターの配線を損傷しないように注意しながら、リアパネルユニット (C) を引き抜き、適切に支えます。

フレーム (E) からキャップ (D) を取り外します。

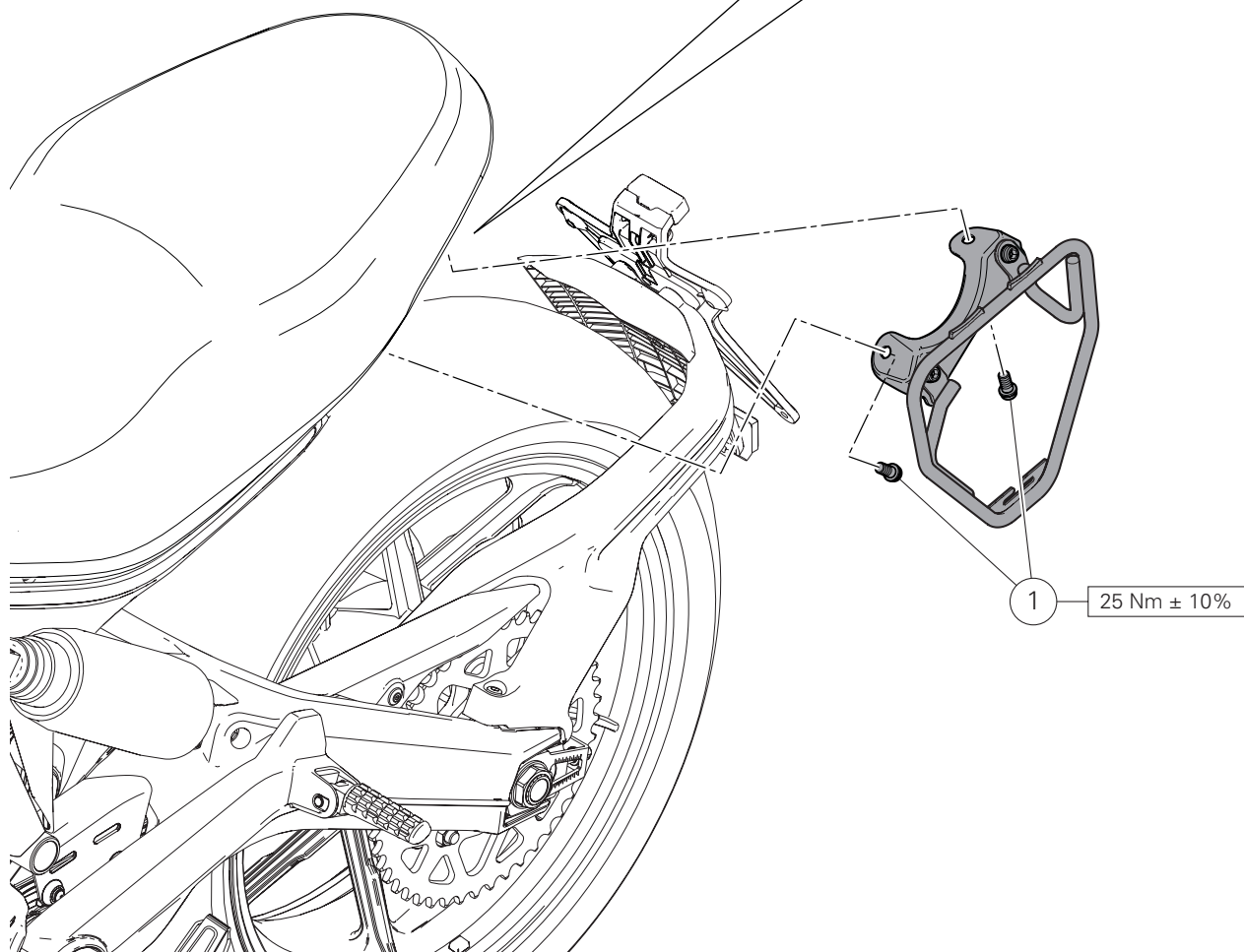
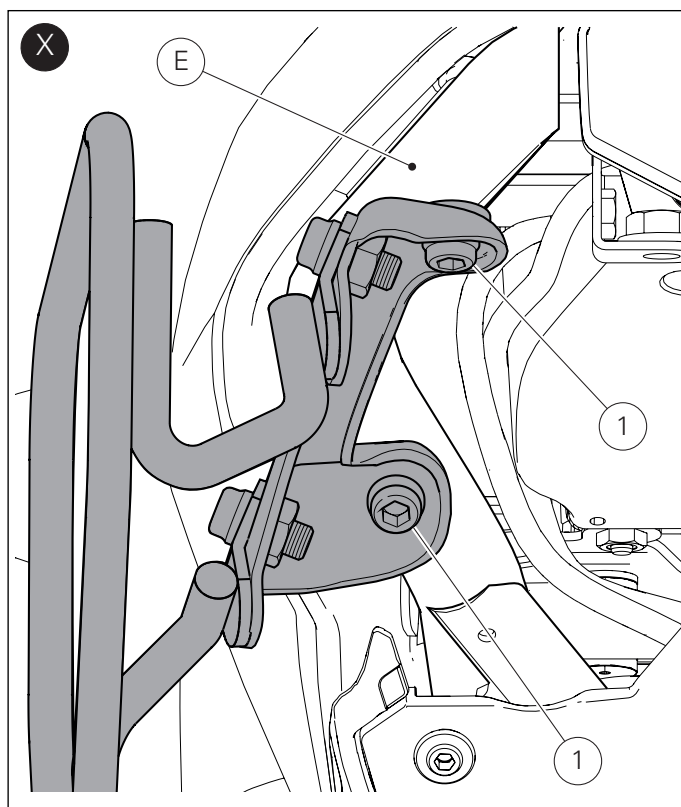
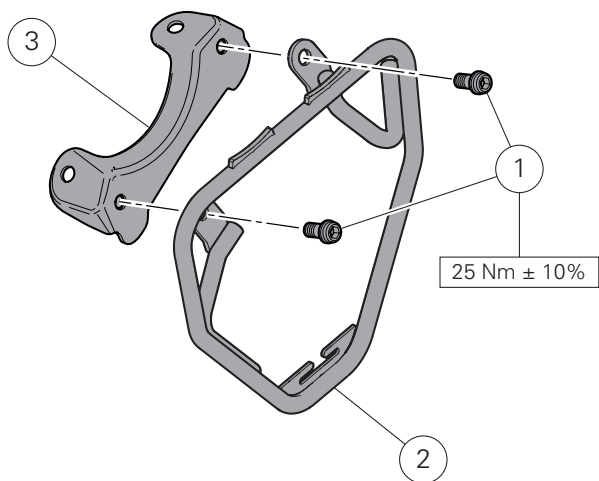

Montaje componentes kit



Importante

Controlar, antes del montaje, que todos los componentes se encuentren limpios y en perfecto estado.
Adoptar todas las precauciones necesarias para evitar daños en la superficie exterior de los componentes donde se debe operar.

Pre-montaje grupo subchasis izquierdo

Pre-montar la placa soporte bolsa izquierda (3) en el subchasis izquierdo (2) introduciendo los 2 tornillos (1).
Ajustar los 2 tornillos (1) al par de apriete indicado.

Montaje grupo subchasis izquierdo

Fijar el grupo subchasis izquierdo al bastidor (E) introduciendo los 2 tornillos (1) como se indica en la figura (X).
Ajustar los 2 tornillos (1) al par de apriete indicado.

キット部品の取り付け



重要

取り付け前にすべての部品に汚れがなく、完璧な状態であることを確認します。作業する部品の外側表面を傷つけないために、必要な予防措置を取ってください

左サブフレームユニットの仮取り付け

左バッグマウントプレート (3) を左サブフレームユニット (2) に仮取り付けし、2 本のスクリュー (1) を差し込みます。
2 本のスクリュー (1) を規定のトルクで締め付けます。

左サブフレームユニットの取り付け

図 (X) のように、左サブフレームユニットをフレーム (E) に固定し、2 本のスクリュー (1) を差し込みます。
2 本のスクリュー (1) を規定のトルクで締め付けます。

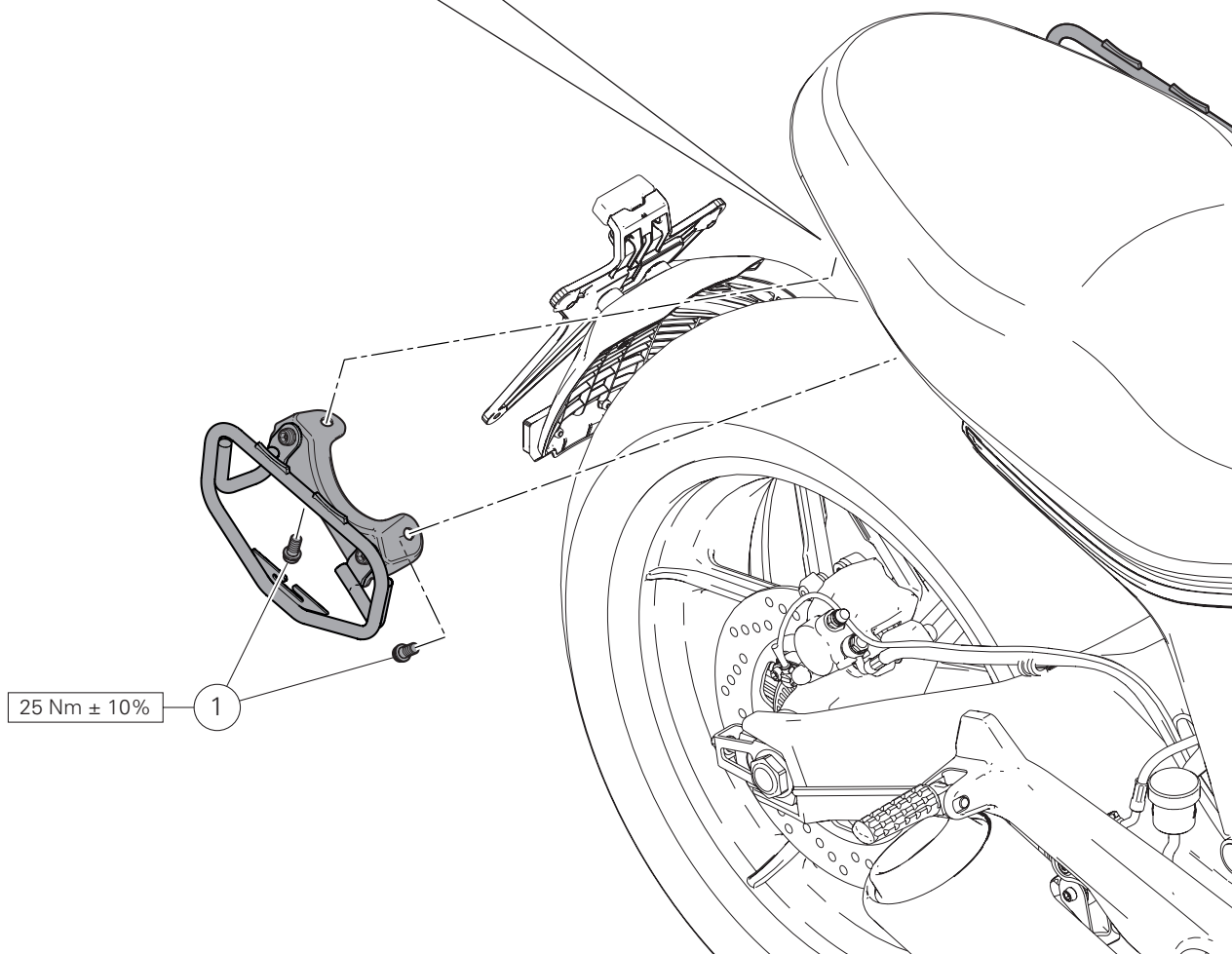
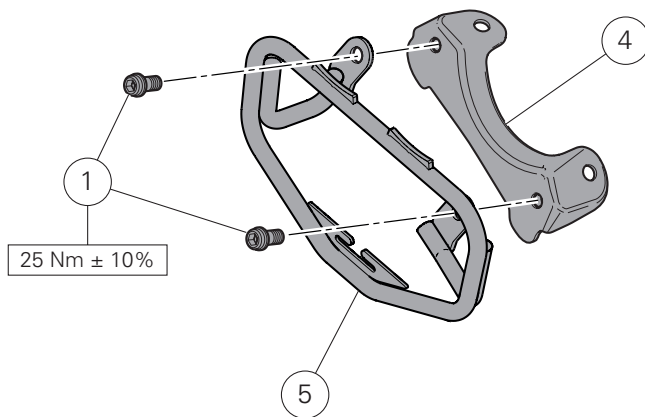
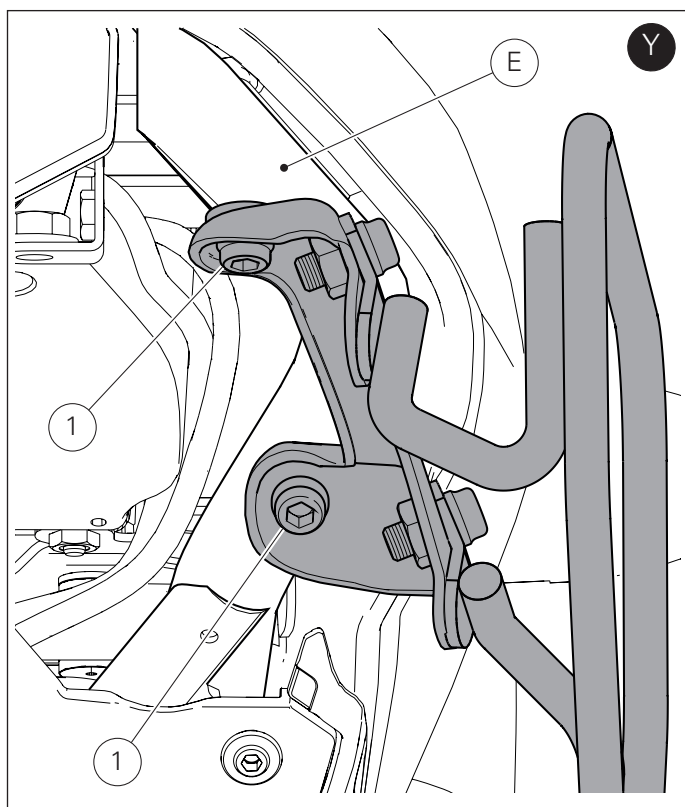

Pre-montaje grupo subchasis derecho

Pre-montar la placa soporte bolsa derecha (4) en el subchasis derecho (5) introduciendo los 2 tornillos (1).
Ajustar los 2 tornillos (1) al par de apriete indicado.

Montaje grupo subchasis derecho

Fijar el grupo subchasis derecho al bastidor (E) introduciendo los 2 tornillos (1) como se indica en la figura (Y).
Ajustar los 2 tornillos (1) al par de apriete indicado.

右サブフレームユニットの仮取り付け

右バッグマウントプレート (4) を右サブフレームユニット (5) に仮取り付けし、2 本のスクリュー (1) を差し込みます。
2 本のスクリュー (1) を規定のトルクで締め付けます。

右サブフレームユニットの取り付け

図 (Y) のように、右サブフレームユニットをフレーム (E) に固定し、2 本のスクリュー (1) を差し込みます。
2 本のスクリュー (1) を規定のトルクで締め付けます。

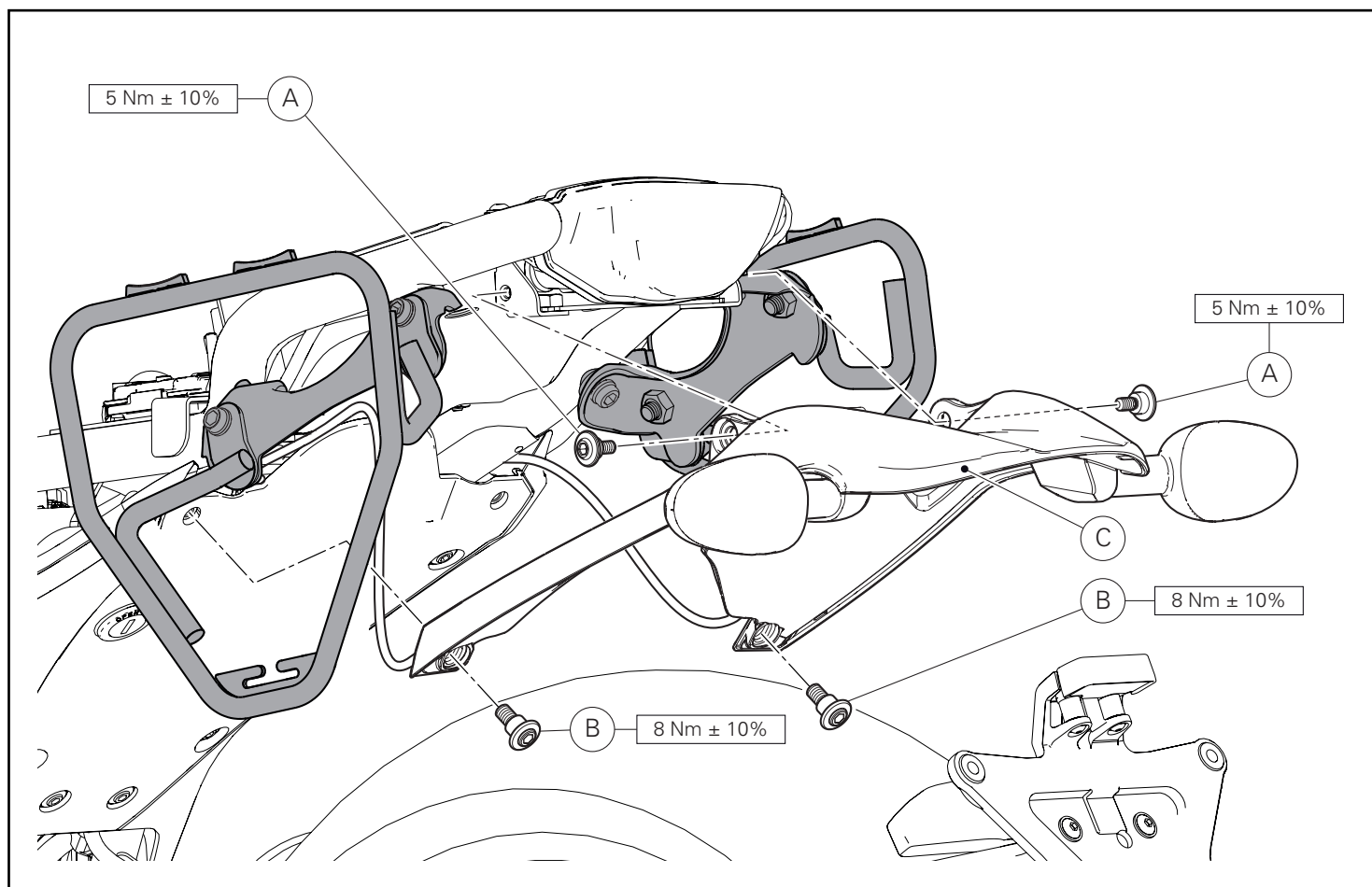

Posicionar el grupo protección trasera (C) en el bastidor e introducir los 2 tornillos superiores (A).

Introducir los 2 tornillos inferiores (B) que fijan el grupo protección trasera (C) al bastidor.

Fijar el grupo protección trasera (C) ajustando los 2 tornillos superiores (A) y los 2 tornillos inferiores (B) al par de apriete indicado.

リアパネルユニット (C) をフレームに配置し、2 本のアップースクリュー (A) を差し込みます。

リアパネルユニット (C) をフレームに固定する 2 本のロアスクリュー (B) を挿し込みます。

2 本の上側のスクリュー (A) および 2 本の下側のスクリュー (B) を規定のトルクで締め付け、リアパネルユニット (C) を固定します。

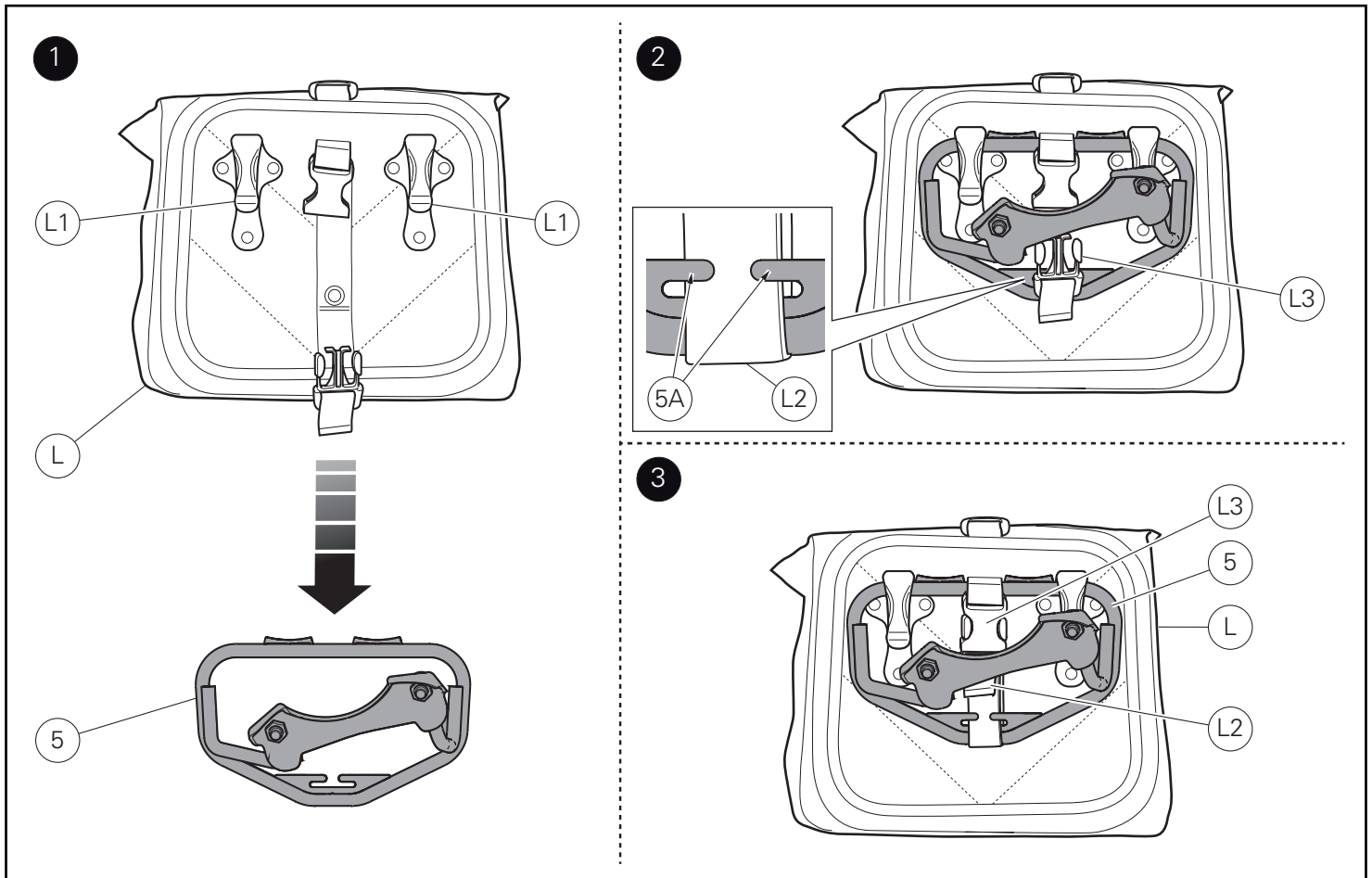

Montaje bolsas laterales

👁️ Notas

En el kit subchasis (96780741A) es posible montar el Kit bolsas laterales herméticas URBAN ENDURO (96780751A) y el Kit bolsas laterales suaves CLASSIC (96780761A).

👁️ Notas

Es posible adquirir en un concesionario/dealer autorizado el Kit bolsas laterales herméticas URBAN ENDURO (96780751A) y el Kit bolsas laterales suaves CLASSIC (96780761A).

👁️ Notas

Para comprender mejor el enganche de la bolsa en el respectivo subchasis, se representa el grupo subchasis soporte bolsa, desmontado de la motocicleta.

Apoyar los enganches (L1) de la bolsa derecha (L) al subchasis derecho (5) y empujar hacia abajo hasta escuchar el click, como ilustra la figura (1).

Hacer pasar la correa (L2) de la bolsa en el interior del subchasis e introducirla en las aletas inferiores (5A), como ilustra la figura (2). Enganchar la hebilla (L3) y tirar la correa (L2) para fijar correctamente la bolsa derecha (L) al subchasis derecho (5), como ilustra la figura (3).

Repetir la misma operación para enganchar la bolsa izquierda (M) al subchasis izquierdo (2).

サイドバッグ取り付け

👁️ 参考

サブフレームキット (96780741A) には、URBAN ENDURO 防水サイドバッグキット (96780751A) および CLASSIC ソフトサイドバッグキット (96780761A) を取り付けることができます。

👁️ 参考

正規販売店にて URBAN ENDURO 防水サイドバッグキット (96780751A) および CLASSIC ソフトサイドバッグキット (96780761A) を購入することができます。

👁️ 参考

対応するサブフレームへのバッグの取り付けを分かりやすくするために、バッグマウントサブフレームユニットは車体から取り外されています。

図 (1) のように、右側バッグ (L) のフック (L1) を右サブフレーム (5) に置き、カチッと音がするまで下に押し込みます。

図 (2) のように、バッグのベルト (L2) をサブフレームの内側に通し、下側のつまみ (5A) に挿入します。

図 (3) のように、バックル (L3) を留め、ベルト (L2) を引き、右バッグ (L) を右サブフレーム (5) に正しく固定します。左側のバッグ (M) にも同様の作業を繰り返して、左サブフレーム (2) に取り付けます。

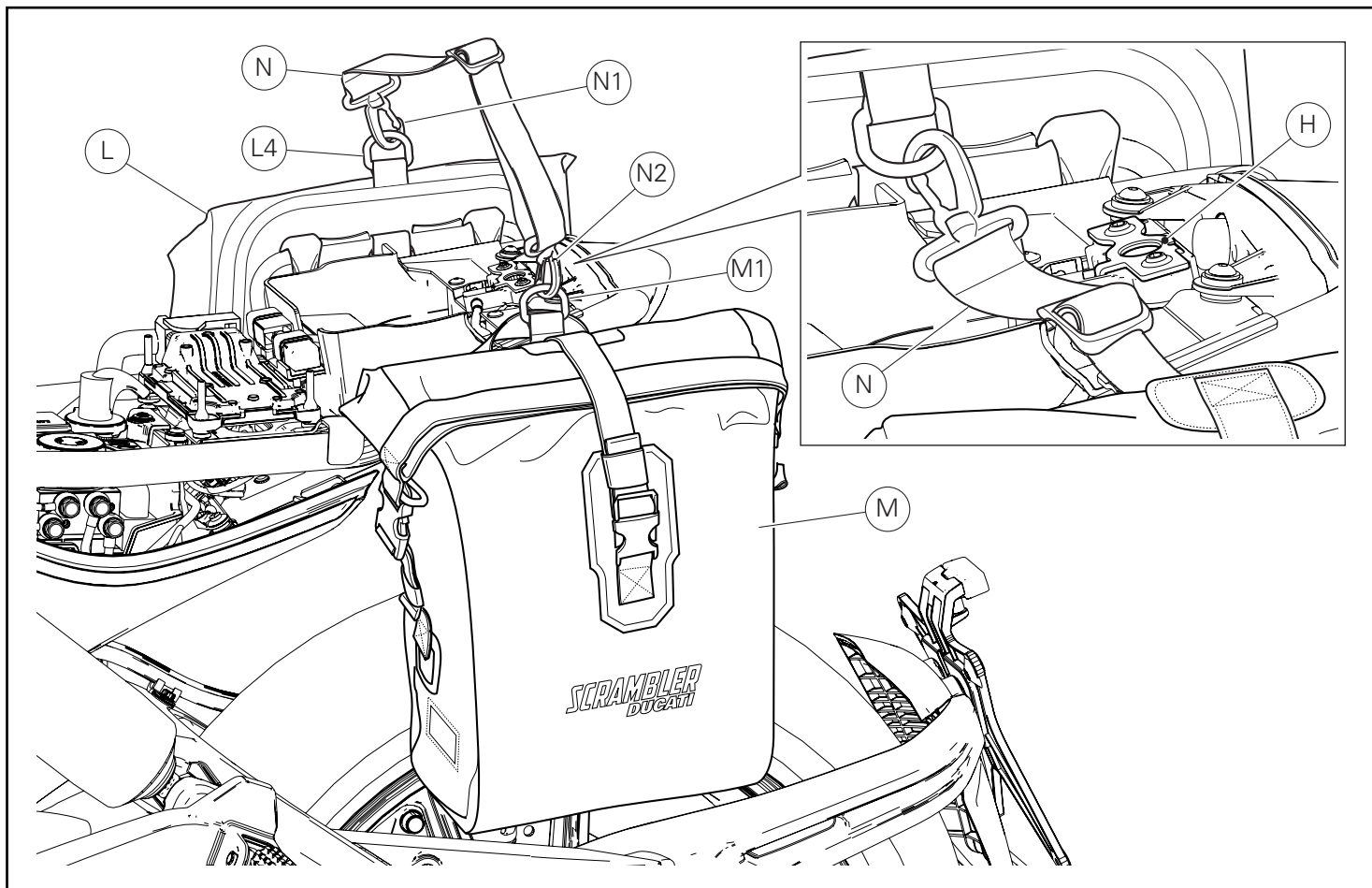

Luego de haber montado ambas bolsas, se deben atar entre ellas con la correa de seguridad (N).

Enganchar la correa de seguridad (N) con el específico enganche (N1), al anillo (L4) presente en la bolsa derecha (L).

Enganchar el otro extremo de la correa de seguridad (N) al anillo (M1) presente en la bolsa izquierda (M), utilizando el enganche (N2).

Tensar la correa de seguridad (N).



Atención

La correa de seguridad (N) no debe cubrir el enganche (H) del cierre del asiento.



Atención

Controlar periódicamente la integridad de la correa de seguridad (N) y de los respectivos enganches (N1) y (N2).

両方のバッグを取り付けた後、セーフティベルト (NN) で両方のバッグを結び付けます。

専用スナップフック (N1) 付きセーフティベルト (N) を右バッグ (L) のリング (L4) に固定します。

セーフティベルト (N) の反対側の端を、左バッグ (M) のリング (M1) にスナップフック (N1) で固定します。

セーフティベルト (N) を引っ張ります。



注記

セーフティベルト (N) がシートクロージングフック (H) を覆わないようにしてください。



注記

セーフティベルト (N) およびそれぞれに対応するスナップフック (N1) および (N2) に傷や破損等がないことを定期的を確認してください。

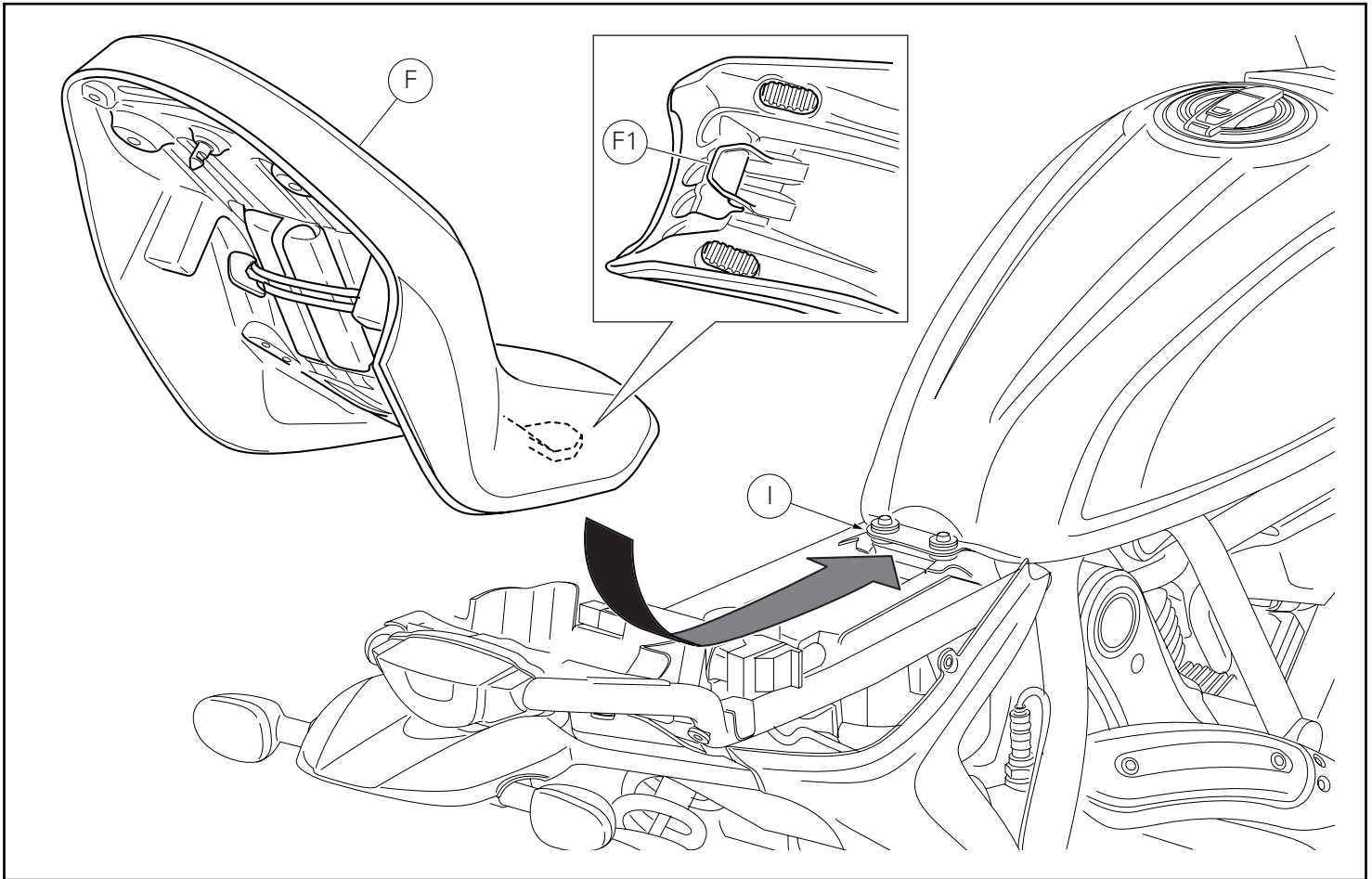

Asegurarse de que todos los elementos se encuentren correctamente dispuestos y fijados en el compartimiento debajo del asiento.

Introducir el extremo delantero (F1) del fondo asiento debajo del alojamiento (I) del soporte bastidor.

Empujar el extremo trasero del asiento (F) hasta escuchar el clic del pestillo de la cerradura.

Asegurarse de que el asiento se encuentre fijado firmemente al bastidor y quitar la llave de la cerradura.



Atención

Es obligatorio respetar los límites de velocidad establecidos por el país en el cual se circula, de todas maneras, está prohibido superar los 130 km/h con las bolsas laterales montadas en la moto.



Importante

La continua y prolongada exposición a los agentes atmosféricos puede causar minimamente o sensiblemente cambios en el color del tejido/material.



Atención

El peso máximo que pueden transportar las bolsas laterales es de 3 kg para la bolsa izquierda y 1,5 kg para la derecha.

Si se excede el peso recomendado, se corre el riesgo de que se rompan las bolsas.

Esto puede influir de manera negativa en la seguridad del piloto.



Importante

Quando se lava la moto es necesario extraer las bolsas laterales.

すべてのエレメントが正しい位置にあり、シート下に固定されていることを確認します。

シート底部の前端部 (F1) をフレームマウントの取り付け位置 (I) の下に挿入します。

シート (F) の最後部をロックの掛け金がかちつとなるまで押しします。

シートがフレームにしっかりと固定されたことを確認し、鍵穴からキーを抜きます。



注記

ご使用になる国で規定されている制限速度を遵守してください。いずれの場合も、車両にサイドバッグを取り付けた状態では絶対に 130 Km/h を超える速度で走行しないでください。



重要

長期間にわたり連続して大気にさらすと、生地/素材の色が若干変化することがあります。



注記

サイドバッグの最大積載重量は、左側バッグが 3 Kg で右側バッグが 1.5 Kg です。

推奨重量を超えた場合、バッグが破損するおそれがあります。

バッグが破損すると、ライダーの安全に悪影響を及ぼすおそれがあります。



重要

車両を洗浄する際、サイドバッグを取り外す必要があります。

NOTAS / 参考

[This area contains a series of horizontal dotted lines for writing notes.]



DUCATI PERFORMANCE accessories

レース専用部品 ご注文書

ご注文商品

1 P/N

商品名

2 P/N

商品名

3 P/N

商品名

4 P/N

商品名

5 P/N

商品名

お客様ご記入欄

私は上記レース専用部品を下記車両に装着し、サーキット走行のみに利用し、一般公道には利用しません。

車台番号 ZDM

モデル名

お客様署名

ご注文日

ドゥカティ正規ネットワーク店記入欄

お客様に上記レース専用部品を販売し、レース専用部品のご利用方法を説明いたしました。

販売店署名

販売日

年

月

日

販売店様へお願い

- 上記ご記入の上、弊社アフターセールス部までFAXしてください。FAX:03-6692-1317
- 取り付け車両1台に1枚でご使用ください。

Kit telaietti borse laterali morbide / Soft side pannier subframe kit / Kit sous-cadres valises latérales souples /
Kit Halterahmen weiche Seitenkoffer / Conjunto de subchassis para bolsas laterais macias / Kit subchasis bolsas laterales suaves /
ソフトサイドバッグサブフレームキット

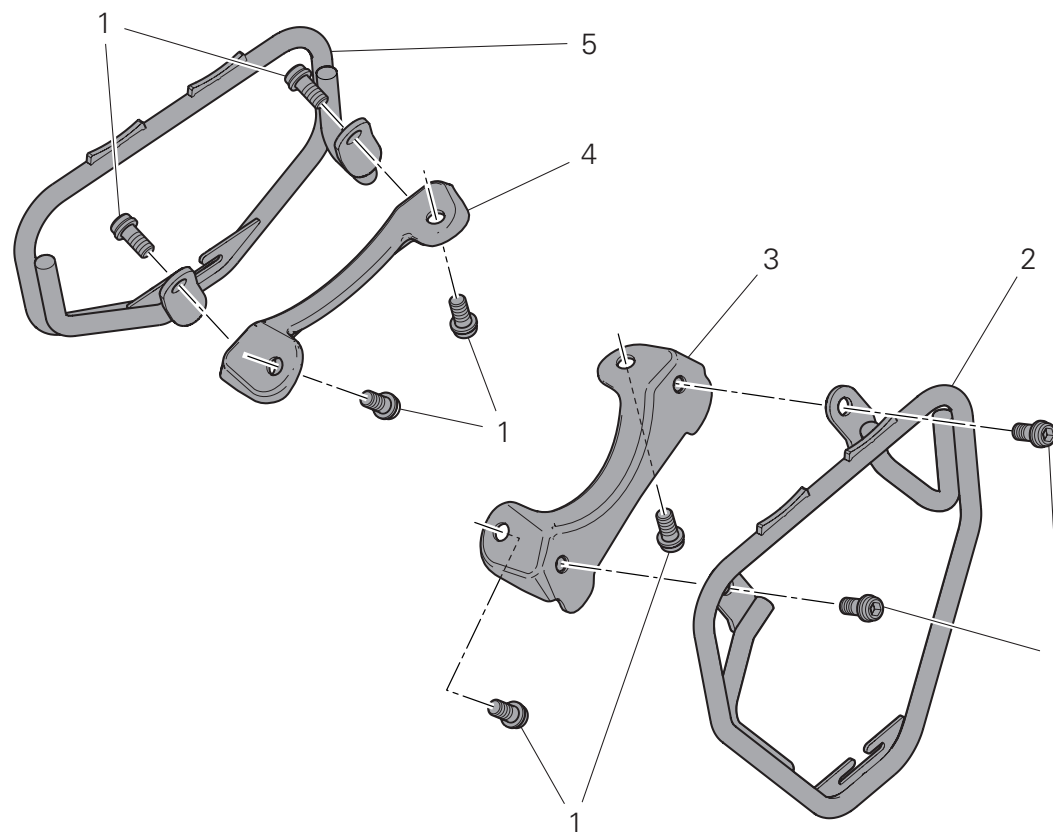
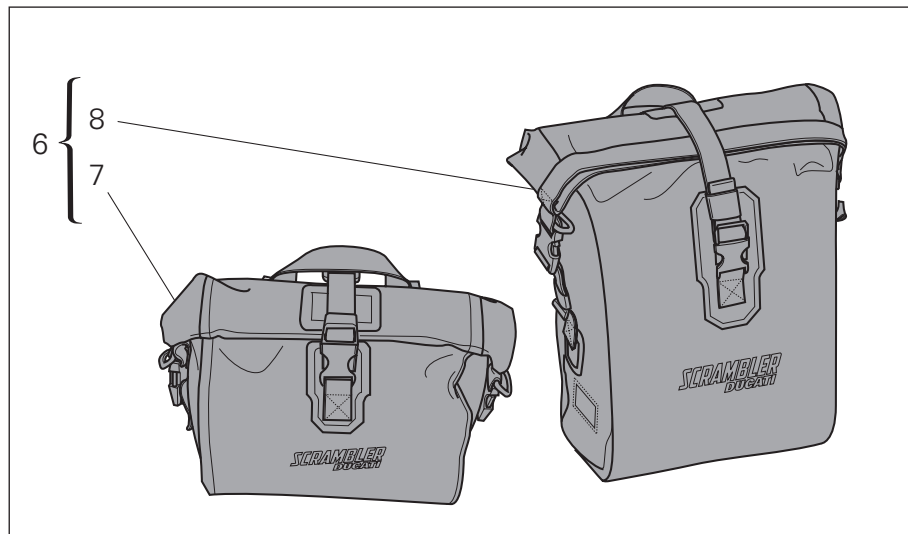
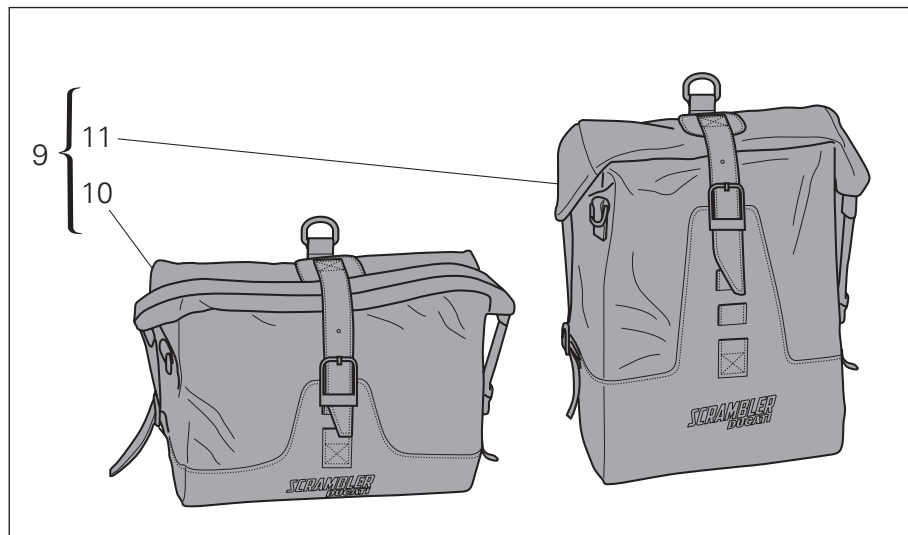

Pos.	Cod.	Denominazione	Description	Designation	Bezeichnung	Descrição	Denominacion	説明	Q.ty
1	77157213B	Vite TCEIF M8x16	TCEIF screw M8x16	Vis TCHC M8 x 16	Geflanschte Innensechskantschraube M8x16	Parafuso de cabeça cilíndrica flangeada com sextavado interno M8x16	Tornillo especial TCEIF M8x16	TCEIF M8x16スクリユー	8
2	96710482AA	Telaio supporto borse sinistro	LH pannier support subframe	Sous-cadre support valises gauche	Linker Kofferhalterrahmen	Subchassi de suporte das bolsas esquerdo	Subchasis soporte bolsas izquierdo	左バッグマウントサブフレーム	1
3	96710422AA	Piastra supporto borse sinistra	LH pannier support plate	Plaque de support valises gauche	Linke Kofferhalterplatte	Placa de suporte das bolsas esquerda	Placa soporte bolsas izquierda	左バッグマウントプレート	1
4	96710412AA	Piastra supporto borse destra	RH pannier support plate	Plaque de support valises droite	Rechte Kofferhalterplatte	Placa de suporte das bolsas direita	Placa soporte bolsas derecha	右バッグマウントプレート	1
5	96710472AA	Telaio supporto borse destro	RH pannier support subframe	Sous-cadre de support valises droit	Rechter Kofferhalterrahmen	Subchassi de suporte das bolsas direito	Subchasis soporte bolsas derecho	右バッグマウントサブフレーム	1
6	96780751A	Kit borse laterali stagne URBAN ENDURO	Sealed side pannier kit - URBAN ENDURO	Kit valises latérales étanches URBAN ENDURO	Kit Seitenkoffer wasserdicht URBAN ENDURO	Conjunto de bolsas laterais herméticas URBAN ENDURO	Kit bolsas laterales estancas URBAN ENDURO	URBAN ENDURO 防水サイドバッグキット	1
7	96710461A	Borsa morbida destra	RH side pannier	Sacoche droite	Rechte weiche Tasche	Bolsa macia direita	Bolsa suave derecha	右ソフトバッグ	1
8	96710451A	Borsa morbida sinistra	LH side pannier	Sacoche gauche	Linke weiche Tasche	Bolsa macia esquerda	Bolsa suave izquierda	左ソフトバッグ	1
9	96780761A	Kit borse laterali morbide CLASSIC	CLASSIC side pannier kit	Kit sacoches latérales CLASSIC	Kit weiche Seitentaschen CLASSIC	Conjunto de bolsas laterais macias CLASSIC	Kit bolsas laterales suaves CLASSIC	CLASSIC ソフトサイドバッグキット	1
10	96710522A	Borsa morbida destra	RH side pannier	Sacoche droite	Rechte weiche Tasche	Bolsa macia direita	Bolsa suave derecha	右ソフトバッグ	1
11	96710512A	Borsa morbida sinistra	LH side pannier	Sacoche gauche	Linke weiche Tasche	Bolsa macia esquerda	Bolsa suave izquierda	左ソフトバッグ	1