

**JTS**



**JTS**<sup>®</sup> PROFESSIONAL CO., LTD.

No. 148, 9th Industry Road, Ta-Li Industrial Park,  
Taichung City, Taiwan.

Tel: 886-4-24938803 Fax: 886-4-24914890

E-mail: [jts@jts.com.tw](mailto:jts@jts.com.tw)

[www.jts.com.tw](http://www.jts.com.tw) Made in Taiwan



59508-132-01

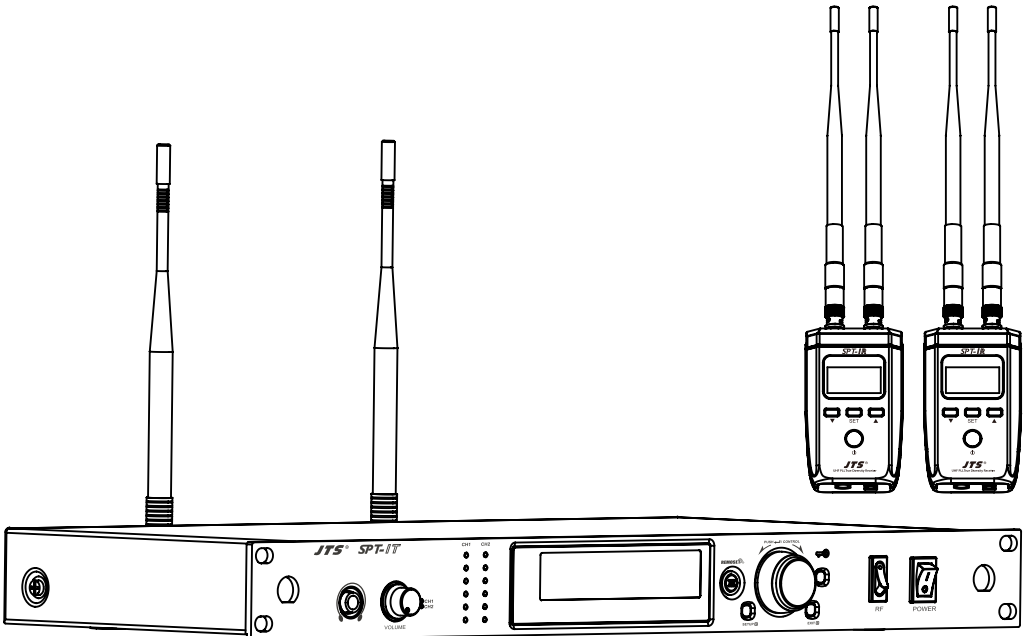

**UHF PLL** Instruction Manual

**SPT-IR / SPT-IT**



## One year product warranty

Product Model		Equipment serial number	
Customer name		Contact number	
Address			
Purchase date			
Selling store stamp	Be sure to put store stamp and fill in purchase date for the warranty to be effective!		

### Warranty description

1. Be sure to put the warranty label indicating purchase date on the bottom of equipment to ensure your interest in maintenance and service.
2. Product warranty, starting on the purchase date indicated on “warranty label”, will last for one year; if the equipment does not have “warranty label”, the warranty period is 15 months from the manufacturing date. If a microphone is broken but not sent back with the equipment, the warranty period is 15 months from the manufacturing date of the microphone.
3. Within the warranty period, if the equipment is broken under normal use as instructed in manual, please contact the original selling store for repair.
4. When the product is returned for repair, to facilitate proper determination of cause of malfunction and of whether repair fee is needed, please ship back the equipment and microphone together.
5. Within the warranty period, our company provides repair service at no cost except for the following conditions that parts and repair may be charged:
  - a. Damages due to natural disaster or irresistible outside forces.
  - b. Damages due to drop, water, moisture, corrosion, foreign objects, missing components.
  - c. The warranty does not cover consumable parts. (such as microphone capsule, ball grille etc.)
  - d. Those without “warranty label” on equipment or with “warranty label” being damaged and failing to identify warranty period.
6. Please keep the warranty properly. No replacement will be made if the warranty is missing.

# Contents

1. Notes for system operations	1
2. Features	1
3. Specifications	2
3-1 UHF PLL True Diversity Receiver // <b>SPT-IR</b>	2
3-2 UHF PLL Transmitter // <b>SPT-IT</b>	3
4. Description of Parts	4
4-1 UHF PLL True Diversity Receiver // <b>SPT-IR</b>	4
4-2 UHF PLL Transmitter // <b>SPT-IT</b>	6
4-3 Accessories	9
5. Connecting	10
5-1 UHF PLL True Diversity Receiver // <b>SPT-IR</b>	10
5-2 UHF PLL Transmitter // <b>SPT-IT</b>	12
6. Instructions for use	13
6-1 How to use // <b>SPT-IR</b>	13
6-2 How to use // <b>SPT-IT</b>	15
7. Notes for the product	20

# 1. Notes for system operations

- Before connecting the power, check that the power requirement shown on the unit is the same as the power output on the adaptor supplied.
- Do not leave the unit at where the humidity and temperature are high.
- Dry your hands before operating the system.
- Keep the unit away from fire and heat source.
- Turn the volume to minimum at both the mixer and amplifier before setting up the system.
- When multiple transmitters are stacked at the same time, it is recommended to use the same group of frequency points to avoid frequency interference.
- Caution : The suitable environment for this product is with a temperature between -10°C (14°F) and +50°C (122°F).

## 2. Features

- The UHF band PLL frequency oscillation mode is used for the transmitter. The receiver utilizes a broadband 36MHz line design, with a total of six groups 1441 frequency points that can be selected, and a built-in mode of non-interference frequency.
- The SPT-1T transmitter combines JTS' patented 2.4GHz REMOSET wireless transmission technology with highly stable circuitry and signal performance, to synchronize frequency and channel settings to the SPT-1R receiver just by pressing a button. The SPT-1R can be used in a wide range of projects and performance venues.
- With the BNC dual antenna receiver terminal, it can increase the receiving distance and eliminate reception noise or radiated noise interference.
- The SPT-1R is compact, cable-free, and can be used by simply attaching it to the speaker. It provides users with six self-contained groups to avoid interference and perfectly reproduce all frequency bands.
- Problem of audio delay is easy to be solved, providing users with: metric feet (0~272 m), feet (0~892 feet) and time (0~800 ms) are converted to three settings for faithful audio signal performance.
- The wireless speaker transmission system transmits audio signals through the SPT-1T and receives them through the SPT-1R, eliminating complicated wiring problems and realizing wireless surroundings.
- Two channels, transmitting on different, non-interfering frequencies, can be used for left and right channel or individual channel transmission.

### 3. Specifications

#### 3-1 UHF PLL True Diversity Receiver // *SPT-IR*

Model	<b><i>SPT-IR</i></b>
Frequency Oscillation	Phase-Locked Loop, PLL
Carrier Frequency	470~960 MHz
Number of Channels	2 Channels
Frequency Matching	2.4GHz RF <b>REMOSET</b> ®
Antenna Selection	True Diversity
Signal to Noise Ratio (S/N)	>106dB(A)
Total Harmonic Distortion (T.H.D)	<0.5%@1KHz
Reception Sensitivity	-95dBm,S/N>80dB
Mirror Rejection Ratio	>80 dB
General Frequency Response	50Hz~18KHz±2dB
Antenna Connector	BNC Female
Display	LCD
Functions Displayed	Group, Channel, Frequency, Antenna A/B, AF Indication, RF Indication, Remoset ID, Delay Time (distance)
Controls	Power Switch, Group, Channel, Frequency, Reception Sensitivity, Key Lock, Delay Time, Display Settings, Language
Audio Output Level (MAX)	Mini XLR Jack : +10dBu(Line) 、 -10dBu(MIC)
Audio Output Impedance	600Ω
Mute	Noise Mute and Pilot Tone
Output Port	Balanced Mini XLR
Power	DCV INPUT 12V/0.5A
Dimensions	365mm(L) x 70mm(W) x 30mm(H)
Remark	Specifications provided above may be slightly different from the product without further notice.

### 3-2 UHF PLL Transmitter // *SPT-IT*

Model	<i>SPT-IT</i>
Frequency Oscillation	Phase-Locked Loop, PLL
Carrier Frequency	470~960MHz
Frequency Matching	2.4GHz RF <b>REMASET</b> ®
RF Power Output	10mW/50mW (according to local regulations)
RF Stability	<±10KHz@Fc
Modulation Frequency Deviation	±48KHz
Spurious Emissions	<-50dBc
LCD Display	Group, Channel, Frequency, Mute, Remoset ID, Volume
Controls	Power, Group, Channel, Frequency, Transmitted Power, Key Lock
Dimension	200mm(L) x 480mm(W) x 46mm(H)
Remark	Specifications provided above may be slightly different from the product without further notice.

# 4. Description of Parts

## 4-1 UHF PLL True Diversity Receiver // *SPT-IR*

- ① **Power Switch** : Press once to turn on; press and hold for two seconds to turn off.
- ② **LCD Display** : Displays the emitter setting parameters.
- ③ **Antenna** : Receiver Antenna
- ④ **Audio Output Connector** : 3P Mini XLR connector.
- ⑤ **SET** : Set the content parameters, which includes frequency, group, channel, reception sensitivity, key lock, delay time, display settings, language.
- ⑥ **▲ / ▼** : Use "SET button" to change parameter setting.
- ⑦ **Power Input Jack** : DCV INPUT 12V/0.5A
- ⑧ **Retainer**

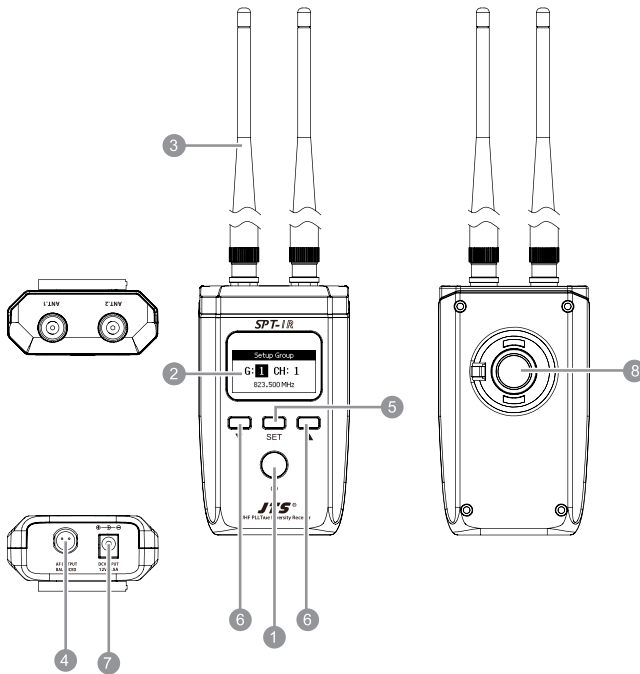



## SPT-1R LCD Display

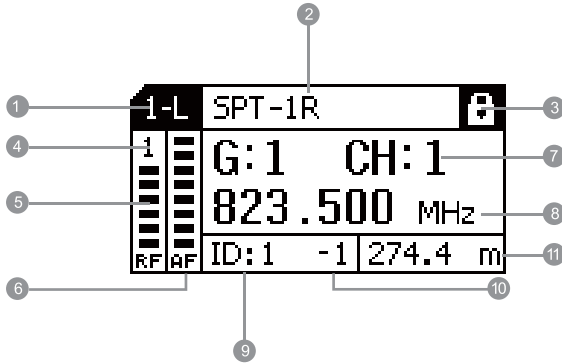

- ① **Transmitter Channel Indication:** indicates the transmitter channel that corresponds to the transmitter via the frequency matching function
- ② **User's Name**
- ③ **Key Lock**
- ④ **Receiver Antenna Indication**
  - 1 : ANT1
  - 2: ANT2
  - ☒ : No signal
- ⑤ **RF Reception Strength Indication**
- ⑥ **Audio Indication**
- ⑦ **The Current Default Group Channel**
- ⑧ **The Current Frequency**
- ⑨ **Remoset ID**
- ⑩ **Remoset ID2**
- ⑪ **Delay Time Indication**

## 4-2 UHF PLL Transmitter // *SPT-1T*

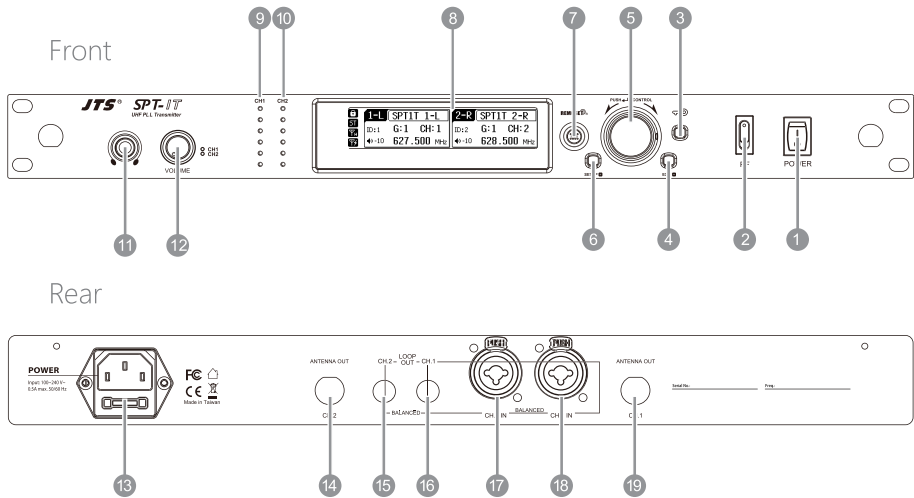

- 1 **Power ON/OFF** :  refers to power "ON".  refers to power "OFF".
- 2 **RF Switch** : Enables/disables the RF signal.
- 3 **Key Lock** : Press and hold for 2 seconds to lock all key functions. Press and hold again for 2 seconds to release the lock.
- 4 **EXIT** : When the SPT-1T is in the "Setup Menu" mode, press EXIT to cancel the selection or exit the menu.
- 5 **Rotary Switch** : When the SPT-1T is in the "Function Setting Menu" mode, rotate the rotary switch to select the desired function up or down.  
Click the rotary switch (or SETUP button) to enter the option, turn the rotary switch to adjust the setting value.  
Press the [SETUP] button to save the settings.
- 6 **SETUP** : Press and hold for about 2 seconds to enter the "Setup Menu" ; press SETUP to save the setting value after selecting and setting according to the "3-Flyer Knob".
- 7 **REMOSET** : When the transmitter is set, press **REMOSET** to send the signal to the receiver.
- 8 **LCD Display** : See [Description of transmitter LCD display]

- ⑨ CH1 Volume Indication
- ⑩ CH2 Volume Indication
- ⑪  $\varnothing$ 6.3 mm Stereo Headphone Jack
- ⑫ **Volume Control/Monitoring Channel Indication:**
  - Rotate: monitoring volume adjustment
  - Press: switching channels
  - CH1, CH2 on together: listen to both channels at the same time
  - CH1 on: listen to CH1 only
  - CH2 on: listen to CH2 only
- ⑬ **AC Power Jack:** 100~240VAC
- ⑭ **CH.2 BNC Antenna Output Jack**
- ⑮ **Balanced Loop Out Connector CH.2 Loop Out**
- ⑯ **Balanced Loop Out Connector CH.1 Loop Out**
- ⑰ **Balanced XLR/ $\varnothing$ 6.3mm Combined Input ( CH.2 Audio Input (Balanced) )**
- ⑱ **Balanced XLR/ $\varnothing$ 6.3mm Combined Input ( CH.1 Audio Input (Balanced) )**
- ⑲ **CH.1 BNC Antenna Output Jack**

## SPT-IT LCD Display Content

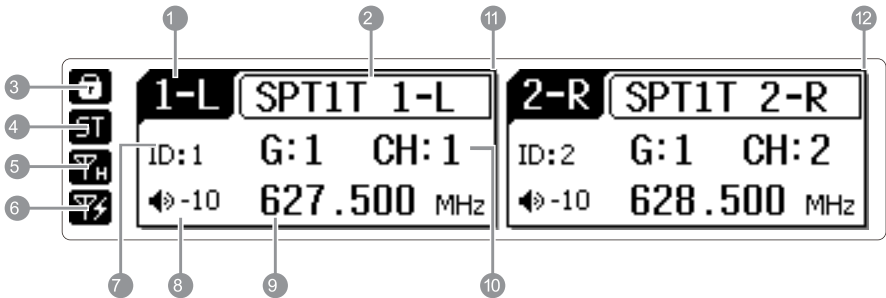

## SPT-IT Setup Screen

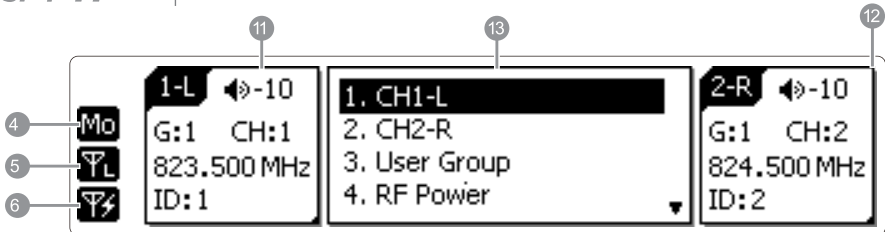

- ① Transmitting Channel Indication
- ② User's Name
- ③ Key Lock
- ④ Stereo/Mono Status Indication  
**ST** : Stereo   **Mo** : Mono
- ⑤ Transmitted Power Status Indication  
**⏏** : High transmitting power   **⏏** : Low transmitting power
- ⑥ RF Emission Status Indication  
**⏏** : RF signals emission on   **⏏** : RF signals emission off
- ⑦ Remoset ID
- ⑧ Volume
- ⑨ Frequency
- ⑩ Preset Group Channels
- ⑪ CH-1L Windows
- ⑫ CH-2R Windows
- ⑬ Setup Menu

### 4-3 Accessories

- ① AC Power Cable (SPT-1T Accessory)
- ② Switching Power Transformer (SPT-1R Accessory)
- ③ Ø 3.5mm X 50cm Cable (mini XLR female to XLR male/SPT-1R Accessory)
- ④ Velcro, Mount, Screws (SPT-1R Accessory)
- ⑤ Transparent Waterproof Cover (SPT-1R Accessory)

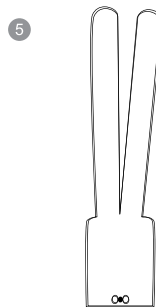
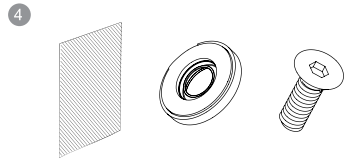
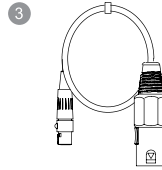
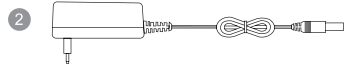

# 5. Connecting

## 5-1 UHF PLL True Diversity connection and installation // *SPT-IR*

### 1. Connecting to the power supply

Connect to the power adapter: Plug the receiver into the DC socket first, and then plug the other end into the AC socket (100~240VAC).

### 2. Connect the audio signal cable

*SPT-IR* audio output connected to active speakers, MIXER or amplifier: connected to active speakers, MIXER or amplifier: *SPT-IR* of the "AF OUTPUT BALANCED" audio output. The other end is connected to the audio input of an active speaker, MIXER or amplifier.

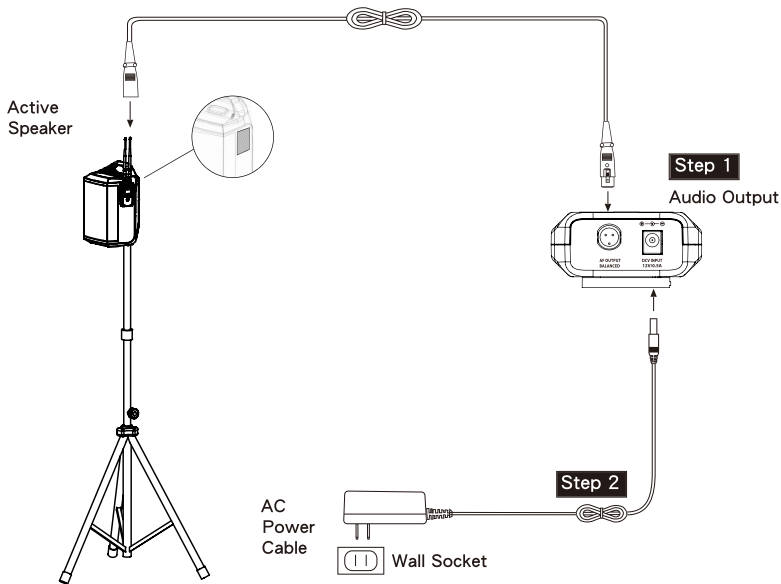

There are two ways to mount receivers to active speakers concerning **SPT-IR** as stated in the content below:

I. Method 1 (speaker with screws):

1. Turn out the screws on the side of the active speaker, lock the attached mount and screws into the screw holes of the speaker (Figure 1).
2. Connect the groove on the back of the **SPT-IR** receiver to the mounting bracket on the active speaker to complete the installation (Figure 2).

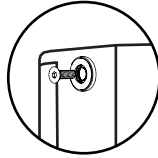

(Figure 1)

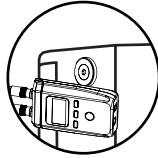

(Figure 2)

II. Method 2 (speaker without screws):

1. Glue the Velcro attached to the back of the **SPT-IR** receiver and the other piece is glued to the flat area of the speaker (Figure 1).
2. Attach the back of the **SPT-IR** receiver and laminate the other piece to the surface of the speaker to complete the installation (Figure 2).

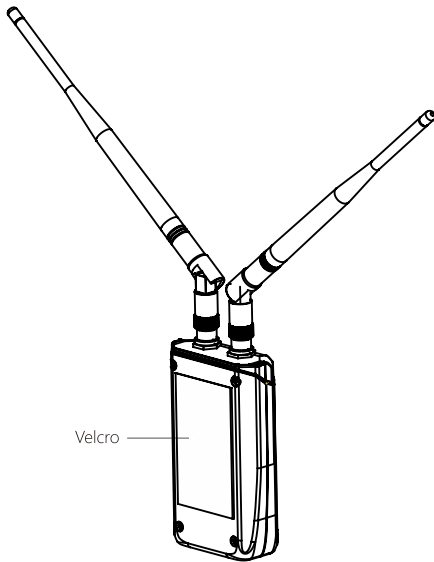

(Figure 1)

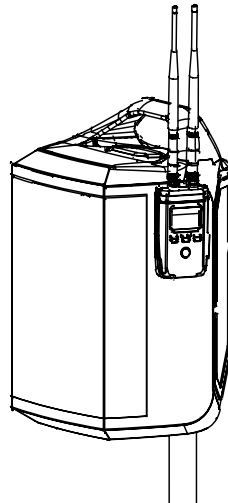

(Figure 2)

## 5-2 UHF PLL Transmitter Installation // *SPT-IT*

### 1. Connecting to the power supply

Connect to the AC power cable: Plug the transmitter into the AC outlet first, and then plug the other end into the AC outlet (100~240VAC).

### 2. Connecting to the audio signal cable

Audio cable: XLR or Ø6.3mm audio cable, one end connects the audio source to the “SPT-IT OUTPUT BALANCED” audio input of the *SPT-IT* receiver, and the other end connects the MIXER to the audio output socket.

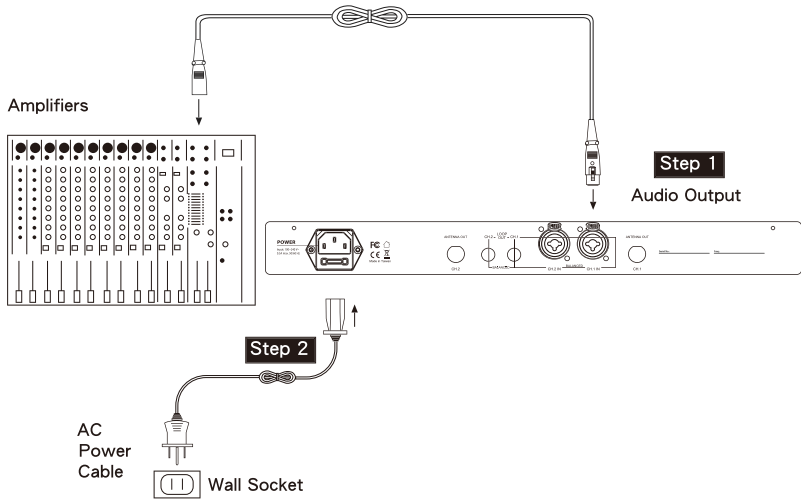



# 6. Instructions for use

## 6-1 How to use // *SPT-IR*

### Parameter Settings

Press the SET button for 2 seconds to enter the setting mode; press the ▲/▼ button to select the item, and press SET again to enter the setting mode. Meanwhile, you can press ▲/▼ keys for parameter setting, press SET again to save the setting and exit.

#### System Settings

#### 1. Frequency

1MHz per unit	Press the ▲/▼ keys to set the frequency.
0.025MHz per unit	Press the ▲/▼ keys to set the frequency.

1. Frequency
2. Group/Channel
3. Squelch
4. Remoset
5. Delay
6. User Name
7. Key Lock
8. Display Options
9. Language
10. Factory Reset
11. Exit

#### 2. Group Channel

G : Group	Select the default group 1~6.
CH : Channel	Select a default channel.

Setup Frequency
<b>823.500</b> MHz
G:1 CH:1

Setup Group
<b>G: 1 CH: 1</b>
823.500 MHz

#### 3. Squelch

+5~ -10: The higher the value, the higher the reception sensitivity. (Default value is 0)

Setup Squelch
0
Low ——— High
0

#### 4. Remoset

Enabled (En)	Frequency can be matched to the transmitter.
Disabled (Dis)	No frequency can be matched to the transmitter.

1. Remoset	En
2. Use ID	Yes
3. ID	1
2. ID2	1
3. Save and Exit	
4. Exit without Save	

#### (1) Use ID

Yes	The ID should be the same as the transmitter in order to match the frequency of the transmitter.
No	All transmitters can be matched to the transmitter regardless of the ID.

(2) ID

ID of SPT-1T and SPT-1R should be the same to complete pairing.

(3) ID2

Please refer to the "Remoset" section of the instruction manual. (P.19)

(4) Save and Exit

Save the settings and return to the main menu.

(5) Exit without Save

Return to the main menu without saving the setting.

5. Delay

Select the unit to be displayed first, either ms, meter or feet, and then press ▲/▼ to adjust the delay time.

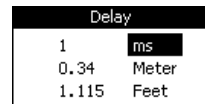

6. Edit User Name

Press the ▲/▼ keys to select a letter, number or symbol, press Set to fill in and set the next word.

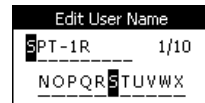

7. Key Lock

Lock	When the frequency pairing is completed, the receiver would stay in the Lock ON mode.
Unlock (default)	The receiver does not lock when the pairing is completed.

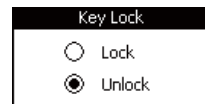

8. Display Options

Contrast : 0~9 (default 5)  
Brightness : 0~9 (default 5)

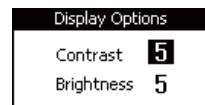

9. Language

English
中文



## 10. Factory Reset

Yes	Restore factory settings
No	Cancellation

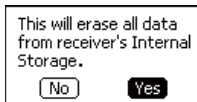

## 6-2 How to use // *SPT-IT*

Press the SETUP key for 2 seconds to enter the setting mode. Use the rotary switch to select the item, click the rotary switch (or press the SETUP key) to enter the setting screen, rotate the rotary switch to adjust the desired value or function, and click the SETUP key to save the setting value. Press the EXIT button to return to the previous page.

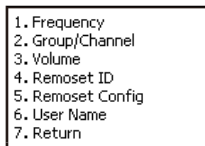
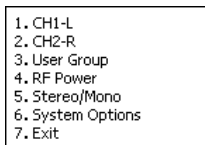

▲ CH1-L, CH2-R Select a list

### 1.~2. CH1-L / CH2-R

#### (1) Frequency

Adjust the left 3-digit frequency; rotate the shuttle knob to "+/- ". Click the shuttle knob after adjusting.

To adjust the right 3-digit frequency, turn the shuttle knob to "+/- ". After setting, press SETUP to save the setting value.

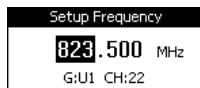

Set the frequency number in 1MHz and then in 0.025MHz.

#### (2) Group / Channel

Spin the rotary switch to select group "G:" group 1~6; press the rotary switch after adjustment.

Spin the rotary switch to adjust the channel "CH:" up to 22 selectable channels and press the SETUP button to save the settings when finished.



Set the frequency number in 1MHz and then in 0.025MHz.

### (3) Volume

Adjustment range: -20dB ~ +20dB



The graph currently sets the sensitivity to Gain 0dB (default)

### (4) Remoset ID

Remoset ID: 0~255. This setting affects the usage of REMOSET; The remoset ID settings of the receiver and transmitter must be the same to enable the REMOSET.



### (5) Remoset Config

SPT-1T can set up 5 different audio delay times to synchronize to 5 receivers with different ID2s when using the remoset function.

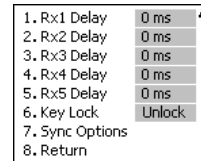

#### #1. ~ 5. Delay Time

Select the unit to be displayed first. You can choose from milliseconds, meters and feet, then click the shuttle to adjust the time delay.

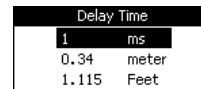

#### #6. Key Lock

Lock	When the frequency pairing is completed, the receiver should remain in the Lock ON mode.
Unlock	The receiver would not be locked when the frequency pairing is completed. (Default value)

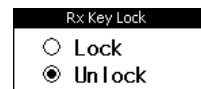

#### #7. Synchronization Options

Use the shuttle to select the REMOSET synchronous transmission setting item, and then press the shuttle button to perform the check.

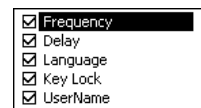

### (6) User Name

Rotate the shuttle to select a letter, number or symbol, then click the shuttle to fill in and set the next word.



### 3. User Group



#### (1) Edit

G: U1~U6 , CH : 1~24

Frequency: When displayed as ---.---MHz, this channel is not enabled.



#### (2) Clear Group

Select the group U1~U6 you want to delete, click SETUP. The program will confirm the group you want to delete again, click "Yes" to start deleting.

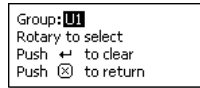

### 4. RF Power

High	High transmitting power
Low	Low Transmitted Power

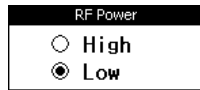

### 5. Stereo / Mono

Stereo	CH-1L, CH-2R input audio with individual transmission.
Mono	CH-1L and CH-2R input audio are mixed and sent.

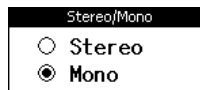

## 6. System Options

(1) Screen Contrast : 0~9 (default 5)

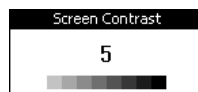

(2) Screen Brightness: 0~9 (default 5)



(3) Indicator Brightness: 0~9 (default 5)



(4) Language

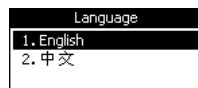

(5) Factory Reset

Yes	Restore to factory settings
No	Cancellation

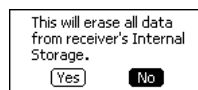

# Remoset

1. REMOSET : Press the REMOSET button and the blue light will start flashing, indicating that the frequency data is being transmitted.
2. REMOSET success: The receiver screen flashes three times.
3. REMOSET failure: If the receiver does not respond, please check:
  - (1) Whether the "frequency range label" "attached" to the receiver and the transmitter is the same
  - (2) "Allowed" setting is required for the "FM function" in the receiver function menu.
  - (3) The receiver and transmitter "Device ID" settings must be the same.

\*When using the REMOSET function, please avoid using the REMOSET function with more than two transmitters at the same time. Avoid interfering with each other's REMOSET signals, which may result in a loss of frequency pairing.

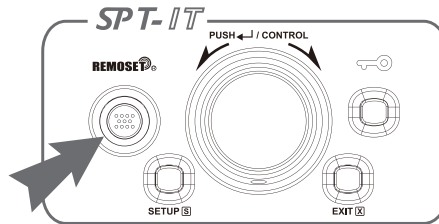

4. SPT-1T can set 5 different delay times altogether, and simultaneously send them to 5 receivers, so that the 5 receivers can have their own delay time settings.

- (1) Rx1 Delayed mapping to receiver ID2 = 1
- (2) Rx2 Delayed mapping to receiver ID2 = 2
- (3) Rx3 Delayed mapping to receiver ID2 = 3
- (4) Rx4 Delayed mapping to receiver ID2 = 4
- (5) Rx5 Delayed mapping to receiver ID2 = 5

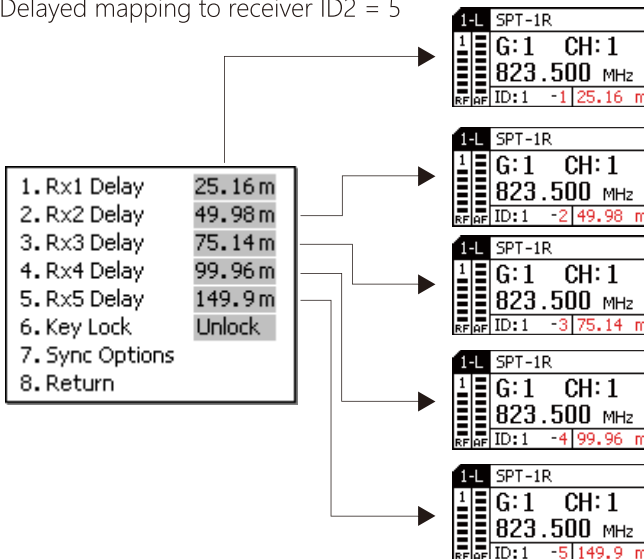

## 7. Notes for the product

- (1) To achieve the best reception of the signals, keep the receiver at least 3 meters apart from the transmitter.
- (2) Keep a distance of at least 50 cm between the receiver, the transmitter and other metal objects.