

■ LDB-101: 1-Channel ACTIVE DIRECT BOX

This unit have its special function for eliminating the noise caused by outside electromagnetic.

1. Operating Elements and Connections

- ① XLR output jack - balanced
- ② Groundlift switch
- ③ Input jack and Link Output jack - unbalanced
- ④ Attenuator Selector switch

2. Important Instructions for Use

- The device is suitable for indoor use only.
- If the device is used for other purposes than originally intended or if it is wrongly operated or not repaired by an expert, no liability can be assumed for any probable damage.
- A transformer coupled device to pick up an instrument's signal for a mixing console, it maintains at the same time the connection between the instrument and its own amplifier.
- Use dry soft cloth for cleaning. Do not use any chemicals or water.
- Should the device definitively be put out of operation, same has to be disposed of in a local recycling plant.

3. Applications

The LDB box(Active Direct Injection) serves as an optimal connection of amusical instrument with high impedance unbalanced output to a low impedance balanced input of a mixer. By means of the balanced connections to the mixer, interferences can also be avoided in case of long connecting cables. In case of problems with hum loops, the ground connections between instrument and mixer can be separated by means of the gnd.lift switch. Then the devices are D.C. separated. High signal levels can be reduced by means of the reductor and can be adapted to the mixer input. There by, the LDB box can also be connected directly to the speaker output of an instrument amplifier. Consequently the influence of the sound at the mixer input will be maintained by the amplifiers(e.g. guitar or tube amplifier).

4. Power Requirements

Powered 9V PP3 Battery or 48V Phantom Power. If your microphone input has 48V Phantom Power the LDB-101 will automatically switch off its Battery and use the phantom. The LDB-101 will operate with phantom voltages as low as 24V but you will need to remove its internal battery first. Battery switched on by inserting Input Jack. To save battery life always remove jack when unit not used.

5. Specifications

Frequency Resp.	----- 20Hz to 20KHz ±0.5dB
Attenuator	----- 0, -30 dB
Inputs Impedance	----- 1MΩ, unbalanced 1/4" jack
Outputs Impedance	----- 600Ω, balanced XLR
Power Requirements	----- 9V PP3 Battery or 48V Phantom Power
Dimensions (WxHxD)	----- 81 x 44 x 130 mm
Weight	----- 498 g

EWI



<Bass guitar setup>

<Lead Guitar setup>

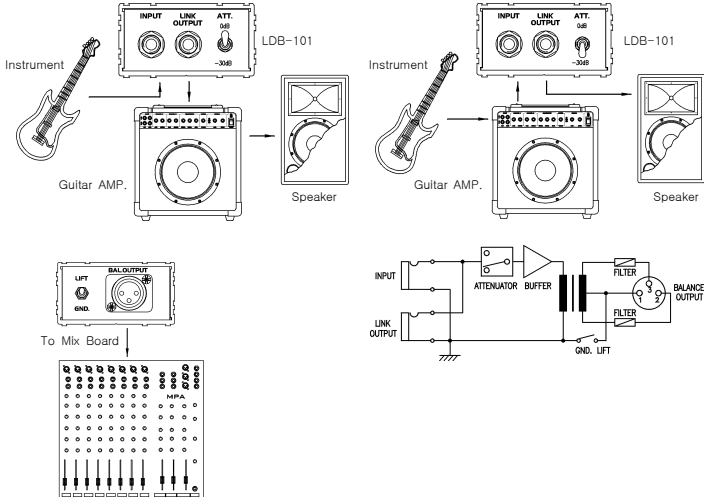

■ LDB-101: 1-Channel ACTIVE DIRECT BOX

This unit have its special function for eliminating the noise caused by outside electromagnetic.

1. Operating Elements and Connections

- ① XLR output jack - balanced
- ② Groundlift switch
- ③ Input jack and Link Output jack - unbalanced
- ④ Attenuator Selector switch

2. Important Instructions for Use

- The device is suitable for indoor use only.
- If the device is used for other purposes than originally intended or if it is wrongly operated or not repaired by an expert, no liability can be assumed for any probable damage.
- A transformer coupled device to pick up an instrument's signal for a mixing console, it maintains at the same time the connection between the instrument and its own amplifier.
- Use dry soft cloth for cleaning. Do not use any chemicals or water.
- Should the device definitively be put out of operation, same has to be disposed of in a local recycling plant.

3. Applications

The LDB box(Active Direct Injection) serves as an optimal connection of amusical instrument with high impedance unbalanced output to a low impedance balanced input of a mixer. By means of the balanced connections to the mixer, interferences can also be avoided in case of long connecting cables. In case of problems with hum loops, the ground connections between instrument and mixer can be separated by means of the gnd.lift switch. Then the devices are D.C. separated. High signal levels can be reduced by means of the reductor and can be adapted to the mixer input. There by, the LDB box can also be connected directly to the speaker output of an instrument amplifier. Consequently the influence of the sound at the mixer input will be maintained by the amplifiers(e.g. guitar or tube amplifier).

4. Power Requirements

Powered 9V PP3 Battery or 48V Phantom Power. If your microphone input has 48V Phantom Power the LDB-101 will automatically switch off its Battery and use the phantom. The LDB-101 will operate with phantom voltages as low as 24V but you will need to remove its internal battery first. Battery switched on by inserting Input Jack. To save battery life always remove jack when unit not used.

5. Specifications

Frequency Resp.	----- 20Hz to 20KHz ±0.5dB
Attenuator	----- 0, -30 dB
Inputs Impedance	----- 1MΩ, unbalanced 1/4" jack
Outputs Impedance	----- 600Ω, balanced XLR
Power Requirements	----- 9V PP3 Battery or 48V Phantom Power
Dimensions (WxHxD)	----- 81 x 44 x 130 mm
Weight	----- 498 g

EWI



<Bass guitar setup>

<Lead Guitar setup>

