

Freiheit®

USER GUIDE

FREIHEIT® FREEDOM WHEELCHAIR

ORDERING CODE: 3035, 3036, 3037, 3040, 3041, 3042



Manual
3035, 3036, 3037



Transit
3040, 3041, 3042

SAFE WORKING LOAD 110KG

CONTENTS

1. Intended use	2	6. Safety labels	5
2. Warnings	2	7. Instructions for use.....	6
3. Safety precautions	3	8. Troubleshooting	12
4. Product specifications	4	9. Care and maintenance	13
5. List of components.....	5	10. Warranty.....	15

1. INTENDED USE

Thank you for choosing from the Freiheit wheelchair range. It is important that you read this user manual carefully before using your new wheelchair.

The German engineered Freiheit Freedom wheelchair supports a heavier working load of 110kg while remaining lightweight and easily transportable. These wheelchairs are suitable for use both indoors and outdoors and available in a range of sizes. The product is only to be used for self-transportation and for transporting people.

The intended occupant is persons who require mobility support due to reduced lower body strength and/or coordination that affects their ability to mobilise without using a seated assistive aid. This may be a result of weakness due to various medical conditions, lower limb amputation/s or fatigue levels.

The user must have adequate sitting balance and trunk control in order to be safe when using this aid.

Persons who are using the self-propelling model must be assessed as having sufficient cognitive, perceptual, and visual ability to operate this mobility aid along with appropriate upper body strength and co-ordination to self-propel.

2. WARNINGS

Symbols used in this user manual and their meanings.



WARNING! Failure to heed this warning may result in damage to the product or serious injury to the operator/user.



ATTENTION! Read and understand the instructions in the user guide before using the product.



CAUTION! Beware of pinch points and entrapment hazards.



WARNING! DO NOT use as a seat in a motor vehicle.

3. SAFETY PRECAUTIONS

The engineering and construction of this wheelchair has been designed to provide maximum safety. Nevertheless, users may put themselves at risk by improperly using their wheelchairs. In order to avoid misuse and dangerous situations, for your own safety, the following rules must absolutely be observed and an assistant is highly recommended.



ATTENTION! This user manual must be read before using the wheelchair. Severe injury or death may result if user instructions, maintenance instructions and product warnings are not followed.



WARNING! DO NOT use as a seat in a motor vehicle.



WARNING! The decision to use this wheelchair should always be guided by a qualified Health Care Professional.



CAUTION! Do not put your fingers into the braking system. Be aware when folding and unfolding the wheelchair.

- **The safe working load is 110kg.** This weight limitation applies to the combined weight of the user and any items carried by the user. DO NOT exceed the safe working load. If you exceed the limit, you may fall, tip over or lose control of the wheelchair and seriously injure yourself or others.
- Prior to using the wheelchair, please check whether all parts attached have been fastened properly.
- The first attempts at moving the wheelchair should take place on a level and manageable surface. Familiarise yourself intensively with the braking and accelerating behaviour of the wheelchair when moving straight ahead and turning corners. It is recommended that a Health Care Professional provide wheelchair training skills to reduce the risk and injury and increase independence of the user.
- Please note that padded parts can become hot in direct sunlight and lead to skin injury on contact. Therefore, cover these parts or protect the wheelchair from direct sunlight.
- The wheelchair may not be misused for transporting several persons or loads. Observe the specific function of the wheelchair.
- Never use your wheelchair while under the influence of alcohol or other substances that may influence your ability to react or your physical and mental receptiveness.
- Please note that redistribution of weight due to body movements or loading the wheelchair can increase the risk of tipping over.
- Approach cross grooves, tracks and similar impassibilities at a right angle (90°), if you cannot move around them.
- There is a danger of tipping over to the rear starting at an angle of +10°.
- Avoid wheeling against obstacles (steps, kerbs) at speed or bumping down steps.
- Never stand on the foot plates to get in and out as the wheelchair could tip over.
- Observe the road traffic regulations when on the road. If possible, wear bright, noticeable clothes so you will be seen better.

- Always make use of elevators and ramps.
- A wheelchair should never be lifted with an occupant; it should only be pushed.
- Before each use, the following should be checked:
 - Quick-release axles (if fitted) on the rear wheels/tyres.
 - Wheel locks.
- Use the wheelchair only for the purpose it is intended for.
- Unprofessional or incorrect adaptation or adjustment work could increase the risk of accidents

4. PRODUCT SPECIFICATIONS

Product Code:	3035	3036	3037	3040	3041	3042
Safe working load	110kg	110kg	110kg	110kg	110kg	110kg
Seat width	400mm	450mm	500mm	400mm	450mm	500mm
Seat depth	420mm	420mm	420mm	420mm	420mm	420mm
Seat angle	2 degrees	2 degrees	2 degrees	2 degrees	2 degrees	2 degrees
Overall width	590mm	640mm	690mm	560mm	610mm	660mm
Overall length	1070mm	1070mm	1070mm	1040mm	1040mm	1040mm
Overall height	910mm	910mm	910mm	910mm	910mm	910mm
Height of push handle	880mm	880mm	880mm	880mm	880mm	880mm
Height of armrest	230mm	230mm	230mm	230mm	230mm	230mm
Width of armrest	50mm	50mm	50mm	50mm	50mm	50mm
Length of armrest	260mm	260mm	260mm	260mm	260mm	260mm
Lower leg length	400mm – 480mm	400mm – 480mm	400mm – 480mm	400mm – 480mm	400mm – 480mm	400mm – 480mm
Closed width	300mm	300mm	300mm	300mm	300mm	300mm
Wheelchair weight	16kg	16kg	16kg	14kg	14kg	14kg
Tilting angle	10 degrees	10 degrees	10 degrees	10 degrees	10 degrees	10 degrees

5. LIST OF COMPONENTS

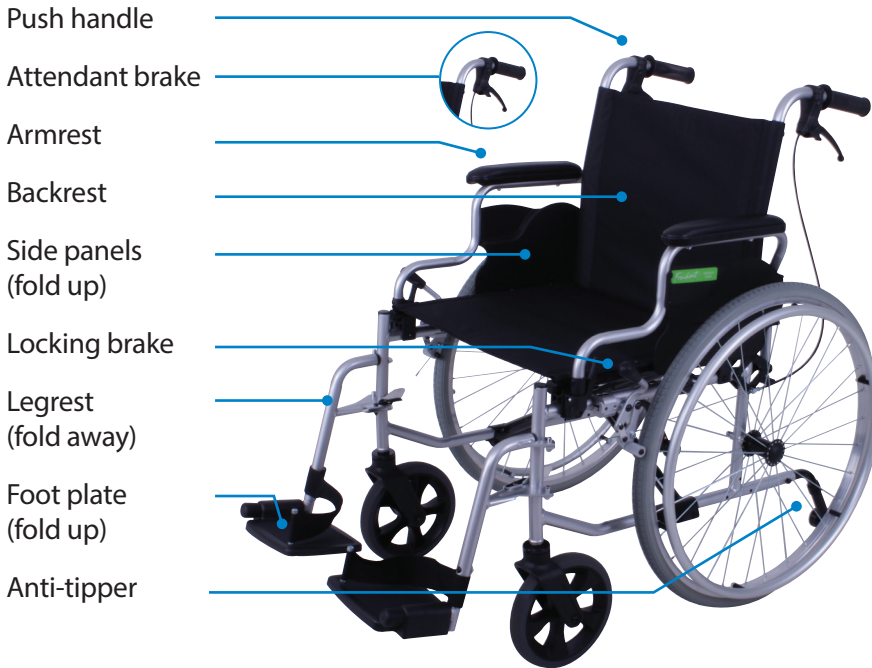

OPTIONS



Elevating legrests

Ordering Code: 5401(L) 5402 (R)



IV Pole with 5° bend to suit Freiheit range

Ordering Code: 5031F

Speak to Cubro about purchasing all of the components as spare parts.

6. SAFETY LABELS

LABELS MARKED ON THE PRODUCT AND THEIR MEANINGS:

Inspected Serial No.
xxxxxxxxxxxxxxxxxxxxxxxxxxxx

Serial number including date of manufacture



Refer to instruction manual



Safe Working Load is 110kg



Do not use as a seat in a motor vehicle. Not AS/NZS 3696.19 compliant



WARNING! All labels must remain readable. Contact Cubro to immediately replace unreadable or missing labels. The serial number label is very important for identifying the product. It must not be removed.

7. INSTRUCTIONS FOR USE

ASSEMBLY

The wheelchair is completely packed in a cardboard box. Please keep the packing, if possible, it may serve for storing the wheelchair at a later time.

Open the carton carefully. Do not use a box cutter or sharp implement as this may cause damage to the product. For your safety, lay the carton on its side with the top of the carton open and slide the plastic bag out containing the wheelchair.

Upon receipt, immediately check the content for completeness and sound condition. The content consists of:

- 1 covering box;
- 1 wheelchair preassembled;
- 1 pair of leg supports with foot plates; and
- 1 user manual.

Generally, your wheelchair is delivered completely assembled, folded and with the drive wheels mounted. To make it ready for use, some easy and simple hand movements are required.

UNFOLDING THE WHEELCHAIR



CAUTION! Be careful not to catch your fingers when following the instructions below.

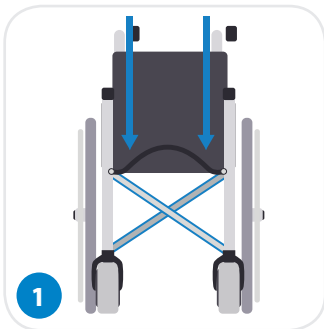

Position yourself behind the wheelchair and press down the cross-bar with both hands.

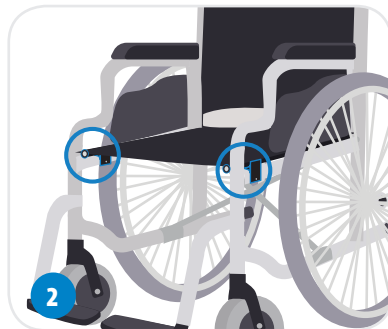

Make sure that the cross-bar engages properly with the supports. You will hear and feel this click into place.

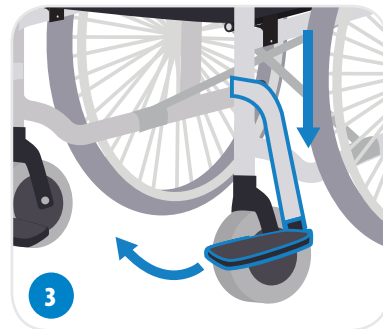

Mount the leg supports and swing them forward, they will snap in audibly.

ADJUSTMENTS

Only trained specialists should adjust brakes. However, should you have sufficient experience, you may also carry out this adjustment yourself. Seek guidance from your Health Care Professional for assistance.



WARNING! Do not attempt to make any adjustments without advice from your Health Care Professional.

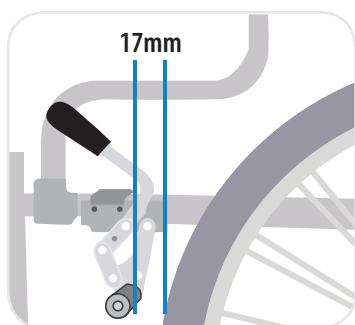

Brakes

The distance between the brake bolts and the tyre cover must be 17mm with the brake fully open.

To adjust the distance, loosen the bolts. Move the brakes into the correct position.

Afterwards, tighten the bolts again and check the brake function.



WARNING! Incorrectly adjusted brakes may result in a life-endangering consequence.

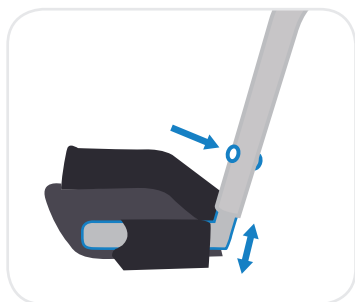

Lower leg length

Loosen the screw and move the foot plate into a position that is comfortable for you.

Tighten the screw again.

FOLDING THE WHEELCHAIR FOR TRANSPORT

Your wheelchair can be easily folded for storage and ease of transportation (such as in a private vehicle). If further disassembly is required, the rear wheels on the manual model are on a quick release mechanism and can be removed easily.

Folding the wheelchair

1. Fold the foot plates upwards.
2. Remove the legrests.
3. Release the velcro strip that connects seat and back upholstery
4. Pull the upholstery upwards in centre. The wheelchair will then fold up automatically.



WARNING! DO NOT use as a seat in a motor vehicle.

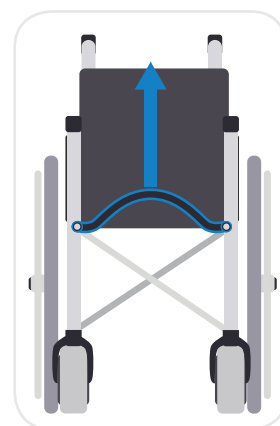

USING YOUR WHEELCHAIR



WARNING! If you ignore these warnings below, you may fall, tip over or lose control of the wheelchair and seriously injure yourself or others or damage the wheelchair.

WARNING! It is recommended that a Health Care Professional provide wheelchair training skills to reduce the risk and injury and increase independence of the user.

WARNING! As a safety measure, the foot plates should always be in an upright position before sitting or getting out of the chair in a forward movement



Side panels

Press the locking lever (1) and lift the side panel (2) upwards.

When folding down, the armrests will automatically lock in place.

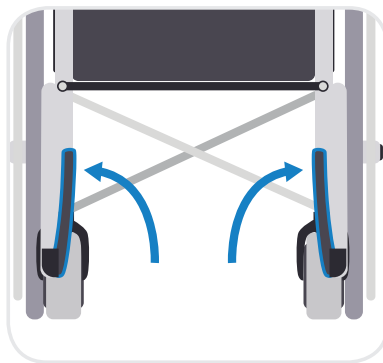

Foot Plates

Fold up the foot plates to facilitate getting in and out.

To fold up the wheelchair in a space saving manner, the foot plates must be folded upwards.



Legrests

To remove the leg supports, first fold up the foot plates.

Now open the locking device (1) and turn the legrests outwards (2).

Now you can remove the legrest in an upward direction (3).

TRANSFERRING IN AND OUT OF YOUR WHEELCHAIR



WARNING! ALWAYS seek guidance from your Health Care Professional to learn safe transfer methods and the level of assistance required.

Transferring in or out of your wheelchair is one of the most dangerous things you can attempt relating to your wheelchair. It requires good balance, agility and upper body conditioning. At some point in every transfer, there is no wheelchair seat beneath you and the seat, bed, etc. to or from which you are transferring is not beneath you either.

Transferring in and out sideways

- The wheelchair allows you to easily get in and out. The foot plates, side panels and legrests can fold away or be retracted.
- Place the wheelchair and the current or future seating surface as close beside one another as possible.
- Should you wish to transfer from another wheelchair or another seat to the wheelchair, make sure that the wheels are secured by applying the locking brake.

- Fold the side panel to the rear.
- Fold the foot plates upwards.
- Fold the leg supports towards the inside or exterior (if necessary, of both wheelchairs when you wish to transfer from one wheelchair to the other). Now slide sideways onto the seating surface.
- Make sure you are sitting in the seat as far back as possible.
- Finally, fold the side panel back down and the legrests back into their home position.

Transferring in and out forwards

- Fold the foot plates upwards and pivot the legrests towards the exterior.
- Place the wheelchair and the current or future seating surface as close to the front of one another as possible.
- Should you wish to transfer from another wheelchair or another seat to the wheelchair, make sure that the wheels are secured by applying the locking brakes.
- Now slide onto the seating surface by twisting your body. Make sure you are sitting in the seat as far back as possible.
- Subsequently, swivel the legrests back in centre position, fold down the foot plates and rest your feet thereon.

MOVING AHEAD WITH THE HELP OF AN ASSISTANT

The assistant controls the wheelchair by pushing the designated pushing handles and utilising the braking system attached to them.

Anti tippers

The anti tippers allow the assistant to tip the wheelchair more easily and hence cross obstacles more easily.

Press down the anti tipper with your foot. Balance can be maintained with the pushing handles.



INDEPENDENT MOVING

Practice safe handling of your new wheelchair on a flat surface with the assistance of an aide, until you get accustomed to it.

Be especially careful when moving on inclined surfaces and when overcoming obstacles.

It is advisable to wear gloves when moving the chair independently.



CAUTION! When moving the wheelchair, make sure that you do not touch the top of the tyre with your thumb. Danger of getting jammed between tyre and side panel.

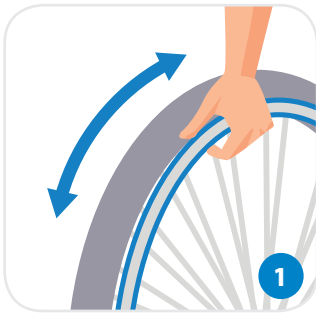

The wheelchair is set in motion and slowed down via the push rim (1).

To move the wheelchair ahead, put your hand on the push rim, so that only your thumb and bent index finger touch the push rim. The other fingers are closed to a fist.

To slow down, let the push rim glide between your thumb and bent index finger and slow it down with a tightening grip until the wheelchair comes to a stop.

To steer the wheelchair into a left and right direction, slow down the push rim on that side you would like to direct it.

To turn the wheelchair on the spot, one hand pushes forward, while at the same time the other hand pushes backwards.

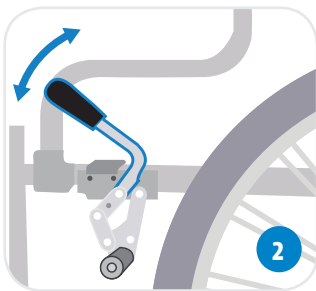

Applying the brakes

Push the brake lever (2) forward until it locks by itself.

You can release the locking brake by retracting the lever.

HILLS, SLOPES, RAMPS AND STEPS



WARNING! ALWAYS seek guidance from your Health Care Professional before attempting to any hills, slopes or ramps.

The center of balance of your chair is affected by the slope of the surface over which you are riding. Because your center of balance will be affected, your chair will be less stable when it is at an angle. This is especially true when riding on a slope sideways. Furthermore, do not assume anti-tips will prevent a fall or tip-over under these conditions.

- NEVER start up or down a ramp unless you are certain the ramp is wide enough for its entire length so your wheels will not fall off the edge.
- NEVER use your chair on a slope greater than 10%—a slope with an elevation greater than one meter in height for every ten meters in length.
- NEVER stop on a steep slope. If you stop on a steep slope, you may not be able to maintain control of the chair.
- NEVER use rear wheel locks as a brake to slow or stop your chair. Wheel locks are NOT brakes. Doing so will most likely cause the chair to veer out of control.
- NEVER try to turn around or change direction when going up or down a slope.

- In order to control your speed, ALWAYS keep pressure with your hands on the hand rims when going down a hill, slope or ramp. If using the attendant propelled model, ensure the attendant slows the chair using the brakes on the push handles.
- DO NOT go too fast. Excessive speed may cause you to lose control of the chair, or it may cause the casters to flutter which can cause a fall or tip-over.
- NEVER exert too much force. The medical team in charge of the user will advise you in the methods best suited to your physiology.



WARNING! The use of anti-tips will not guarantee that your chair will not tip over backward. They will also not prevent your chair from tipping over sideways or forward.



The attendant can use the anti-tipper to raise the front wheels slightly above small curbs.



Take care riding on a slope sideways. Avoid when possible.

ENVIRONMENTAL CONDITIONS/TERRAIN



WARNING! ALWAYS seek guidance from your Health Care Professional before attempting to negotiate any unfamiliar terrain.

Using your wheelchair on wet, icy or other slick surfaces increases the risk of losing control and or tipping over.

The wheelchair is designed for riding over firm, relatively smooth surfaces such as concrete and asphalt outdoors and indoor flooring and carpeting. The wheelchair is NOT designed for riding over sand, loose soil or rough terrain. DO NOT operate your chair in such terrain. You may damage the wheels or axles or loosen fasteners of your chair.



8. TROUBLESHOOTING

Wheelchair is steering/pulling to one side	<ul style="list-style-type: none"> • Make sure the user is able to evenly distribute their weight on the wheelchair • Make sure one push rim has not been mounted more tightly than the other • Ensure both front castors forks are adjusted to the same angle at the frame mounts
The wheelchair moves slowly	<ul style="list-style-type: none"> • Remove any hair or dirt from castor and rear wheel axles • Ensure user clothing is not interfering with movement of the rear wheels • Ensure both brakes are disengaged
The wheelchair does not turn smoothly	<ul style="list-style-type: none"> • Make sure the front fork bolts are not over tightened which can restrict front castor wheel rotation • Remove any hair or dirt from castor axles • Ensure both brakes are disengaged
The brakes do not work properly	<ul style="list-style-type: none"> • Check distance between tyres and brake foot is sufficient such that the requisite amount of force can be applied to the tyre surface to stop it moving when the brake is in the engaged position
The wheelchair cannot be opened or folded easily	<ul style="list-style-type: none"> • Clean the crossbar under the seat and apply some grease • Check that nothing has become lodged under the seat or in and around the cross bar mechanism. • Check foot plates are folded up
The wheelchair is unstable	<ul style="list-style-type: none"> • Ensure all screws, nuts and bolts are tight

Please contact Cubro should you require any assistance.

9. CARE AND MAINTENANCE

All fixings must be checked, adjusted and replaced when necessary throughout the useful lifetime of the chair. In particular, check the front and rear wheels, brakes, hangers, armrests and upholstery regularly.

In addition to the maintenance and checks, general cleaning of both frame and upholstery can be undertaken. The frame parts of the wheelchair can be wiped using a damp cloth. Light soiling can be removed by sponging with a mild detergent and warm water, wiping in the direction of the texture. Rinse off with clean water before allowing to dry. Do not put upholstery in a dryer. The padding materials can be washed up to 40 degrees with mild soap solution sanitised with disinfecting agents on an alcohol basis, where required. In case of heavy soiling, use a mild cleaning agent. To clean the wheels use a damp brush with plastic bristles (do not use a steel brush).

The expected service life of the Freiheit Freedom Wheelchair range is 5 years from date of purchase.



WARNING! Do not use a high-pressure or vapour cleaning device!

A periodic check of the following procedures will help sustain the life and efficiency of your wheelchair:

Weekly	Quarterly	Yearly	Serviceable components
<ul style="list-style-type: none"> • Check for missing or damaged parts. • Check the pressure of the wheels following the instructions indicated on them. • Clean the upholstery with soapy water or adequate products. • Clean the metallic parts of the chair with a dry cloth or with special products for chromium plated or painted surfaces • Check the wheel locks. • Check wear of front and rear tyres. 	<ul style="list-style-type: none"> • Check the castors and adjust if necessary. • Check the castor forks and adjust if necessary. • Check the wheels and adjust if necessary. • Lubricate with industrial oil or grease all parts subject to friction or wear. • Retighten nuts, bolts and screws. 	<p>Service to be completed by authorised Cubro service agent</p>	<p>Wheels Forks Axles Armrests Footrests Seat and back upholstery</p>



WARNING! If faults found during any inspection remove from use immediately.

DISPOSAL

Products that can no longer be used are to be disposed of separately from household rubbish.

This must be done according to the local and national regulations for environmental protection and raw material recycling. Please look at your local council's website for further information on the correct disposal.

SERVICING

For Any Servicing, Maintenance and Troubleshooting Queries,
Please Contact The Cubro Service Dept;

Ph. 0800 656 527

Ph. +64 7 578 7228

E: sales@cubro.co.nz cubro.co.nz

Address: 149 Taurikura Dr, Tauriko, Tauranga, New Zealand



WARNING! Do not make any changes or modifications to this product without consultation from your Cubro agent.

For extra copies of this user guide or a different format
please contact Cubro.

10. LIMITED WARRANTY

1. This warranty applies only to the original purchaser of CUBRO LTD's product (who must be a purchaser who is resident or carrying on business in New Zealand and who has purchased the product directly from CUBRO LTD, or from a CUBRO LTD authorized distributor or reseller in New Zealand) and it is not transferable to any other person or entity.
2. This warranty replaces all conditions, warranties or guarantees that might be implied by law in favour of any person, which are excluded to the fullest extent permissible by law. Where the Consumer Guarantees Act would apply but the purchaser acquires or holds themselves out as acquiring any product for business purposes, the guarantees provided under the Consumer Guarantees Act are excluded in relation to that product.
3. CUBRO LTD warrants the product to be free from defects in materials and workmanship from date of purchase for a period of one year (12 months). This warranty does not cover any damage, defect, expense or loss of any kind caused by accident, misuse, abuse, neglect, negligence, alteration or modification (which includes the use of unauthorised parts or attachments), improper service, repair by other than authorized personnel or any defects not related to materials or workmanship. Wear of components in normal operation and failures resulting therefrom are excluded from this warranty.
4. CUBRO LTD has no obligation to the purchaser and is not obligated to honour all or any part of this warranty unless the following procedure is followed by the purchaser:
 - a. Before making a warranty claim, the purchaser should ensure that the product is defective by following standard 'trouble shooting' procedures and be able to attribute the fault to a defect in materials and/or workmanship of CUBRO LTD;
 - b. If CUBRO LTD determines that the product is not defective, or that the warranty claim is otherwise invalid, CUBRO LTD shall charge the purchaser a handling and servicing fee as well as any freights costs.
 - c. Upon receiving notice from the purchaser of an alleged defect in a product (which defect should be reported to CUBRO LTD immediately), CUBRO LTD will issue a serialized return management authorization (RMA). The purchaser must then return the entire unit or remove, at the purchaser's cost, the defective component part(s) identified, pack the unit or the component part(s) in a manner to avoid shipping damage and to ship the unit or the component part(s) to either CUBRO LTD, or a service centre as specified by CUBRO LTD, within 30 days of the date of the serialized return authorization date.
 - d. If CUBRO LTD require additional information relating to the use of the product by the purchaser or any other relevant information, the purchaser will supply such information as soon as practically possible and in such a manner as CUBRO LTD may reasonably require.
 - e. If CUBRO LTD access the purchaser's claim, it will either repair or replace the product, or repair or replace the defect in workmanship, as it may determine in its sole discretion.
5. Proper selection of a specific product for a specific application and operating environment, and its compatibility with other equipment is the purchaser's responsibility. CUBRO LTD does not warrant the performance of its products or their suitability for a particular purpose.
6. CUBRO LTD shall not be liable under any heading (whether in contract, negligence, or otherwise) for any consequential, indirect or incidental loss or damages of any kind and the maximum aggregate liability of CUBRO LTD (under any one or more headings) shall be the purchase price of the product.



Freephone 0800 656 527
Freefax 0800 428 276
www.cubro.co.nz