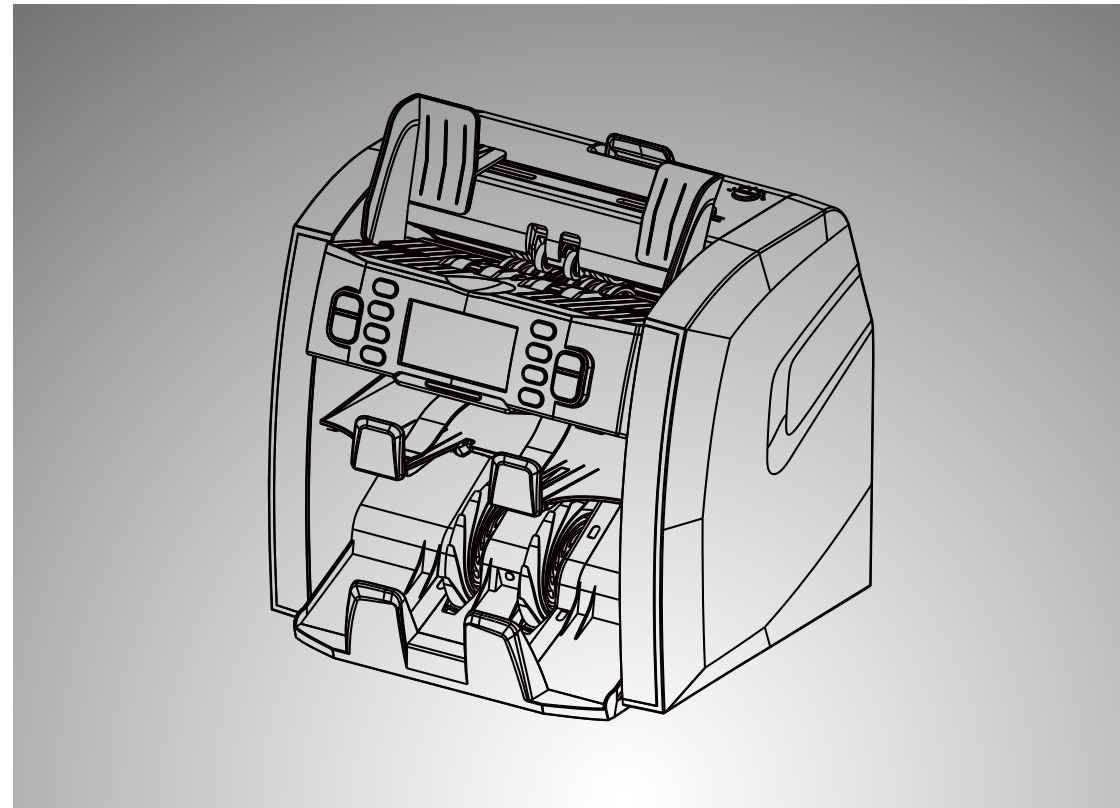


Currency Discriminator/Sorter

User Manual

CR1500



Carnation Enterprises

Contact Phone: 1-800-296-2779

E-mail: info@carnation-inc.com

Website: www.carnation-inc.com

Preface




Thank you for choosing the CR1500 currency counter/sorter. This machine represents the latest development in Carnation technology. In order to make the best use of this currency counter, and its counting/sorting capabilities, please read the manual carefully, and familiarize yourself with the operating procedures.

Contents

Safety	1
Features	2
Unpacking	2
Exterior	3
Operating	5
Display	7
Functions	7
Settings	11
Maintenance	19
Replacing the fuse	20
Adjusting feeder's aperture	20
Software update	21
Specifications	21
Appendix: Error Message	22
Part 1 Self-test error messages and solutions	22
Part 2 Detection error messages and solutions	23
Part 3 Alarm messages and solutions	26

Safety

To avoid damage to the machine and/or personal injury, read the following carefully before the first use!

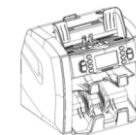
	<ul style="list-style-type: none"> ❖ Place the unit on a flat, solid surface. ❖ Before moving the unit, please disconnect the power cord. Damage to power cord may result in fire and/or electric shock. ❖ Don't place the unit on a flat, solid surface. ❖ Keep the unit away from volatile gases or flammable materials ❖ Keep the unit away from high humidity and strong sunlight, as they may cause machine failure
	<ul style="list-style-type: none"> ❖ In case of water spill, stop operating the unit immediately. Switch it off and disconnect the power cord. Then, contact the service center for help. ❖ Plug the supplied power cord into a grounded outlet only. ❖ If the unit is not in use for a long period of time, please keep it switched off and unplugged to avoid possible damage.
	<ul style="list-style-type: none"> ❖ Please be careful to prevent any foreign objects (i.e. coins, staples, etc.) from falling into the unit, as it may cause damage to the machine. ❖ It is strictly prohibited for anyone except an authorized technician to open/service the machine. Doing so will render any remaining warranty void and may cause malfunction or injury.

Features

1. Detects magnetic ink, infrared ink, UV, CIS image, length, and thickness of banknotes.
2. Compact size and user-friendly interface with large and clear LCD display.
3. Up to 11 different currencies (depending on country software) and banknotes can be processed in all four orientations.
4. High capacity hopper, stacker, and reject pocket.
5. ADD function, batch function, reporting function, and printing functions are available.
6. Intuitive user menu and maintenance menu interface for flexible operation.
7. Auto-adjustable technology and easy software upgrades via SD card or USB port.
8. Configurable USB interface, printer interface, and external display interface.
9. Full, open channel design for better maintenance and jam removal.

Unpacking

The box must contain the following:



Banknote Discriminator



User's manual



Power cord



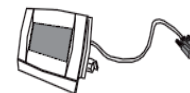
Cleaning brush



Fuse



USB cable (Optional)



External display (Optional)



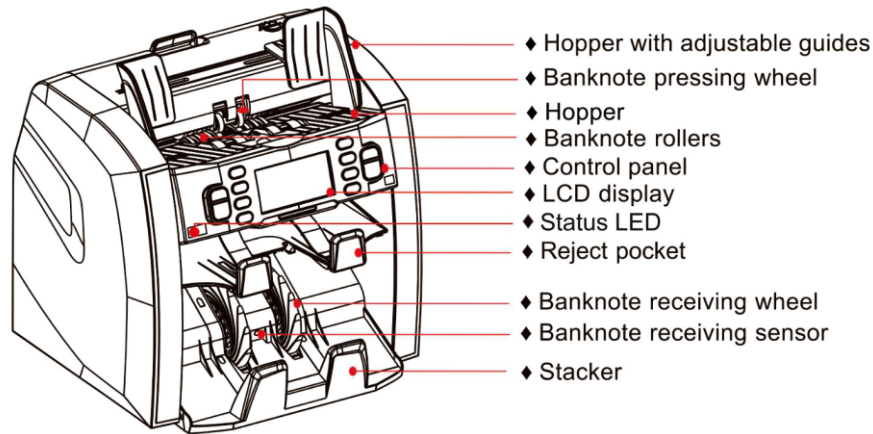
Cable for printer (Optional)



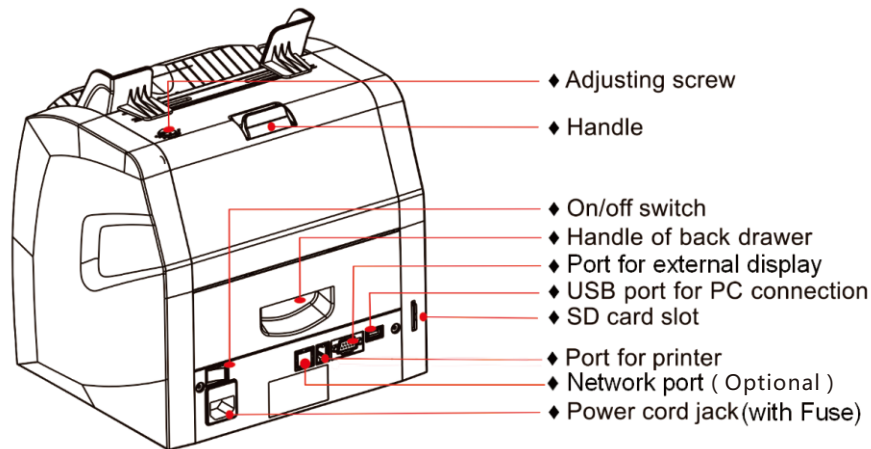
SD card (Optional)

Exterior

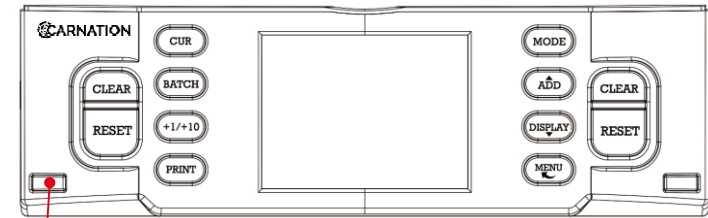
1. Front View



2. Rear View



3. Panel



Status LED **Blue:** indicating notes are in the Reject Pocket with error message
Red: indicating notes are in the Reject Pocket without error message

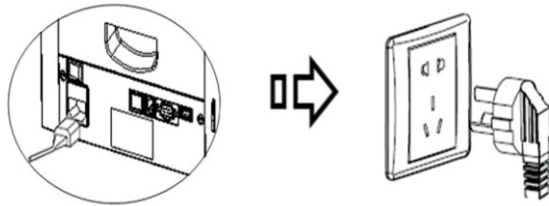
CUR	Currency selection. To set the setting to default value.
BATCH	Batch function on/off and set batch number.
+1/+10	Increase the batch number by 1 (short press) or 10 (press and hold).
PRINT	Send count report to print.
MODE	Counting mode settings: MIX, SINGLE, FACE, ORIENT, COUNT.
ADD	ADD function on/off. Also serves as an upward navigation key.
DISPLAY	View the counting result report. Also serves as a downward navigation key.
MENU	Enter/exit device menu and go back to previous screen (in MENU mode).
CLEAR	Clear the number of counted banknotes and turn the batch function off.
RESET	Start counting/confirm selection in menu mode.

Operating

In order to avoid counting/detection errors, the following must be done before counting:

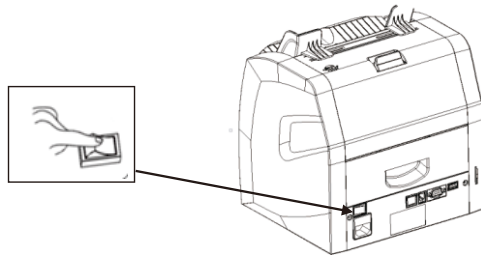
- ① Neatly stack banknotes
- ② Straighten out folded notes/corners
- ③ Remove wrinkled notes
- ④ Remove any foreign objects from the notes (staples, coins, etc.)

Place the unit on a flat, solid surface. Plug in the cord and turn the machine on. Make sure all connections are secure. If you have purchased an external display, connect it to the RS232 port in the back of the machine. Avoid strong electromagnetic fields or direct sunlight.



! Note: In order to ensure personal safety, only use grounded electric outlets.

Turn on the power switch, the machine will display the software version first, then perform a self-test.



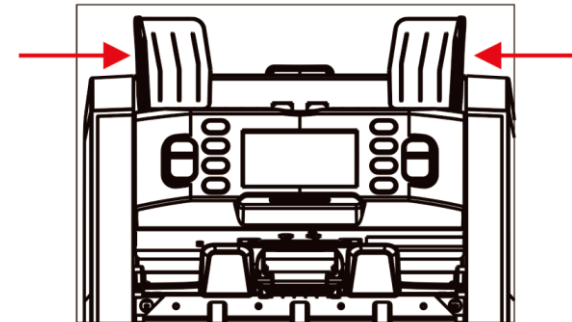
If the test is successful, the machine will enter "ready" state (See figure 1). If some error

messages are displayed on the LCD, please refer to the TROUBLESHOOTING section of the manual.

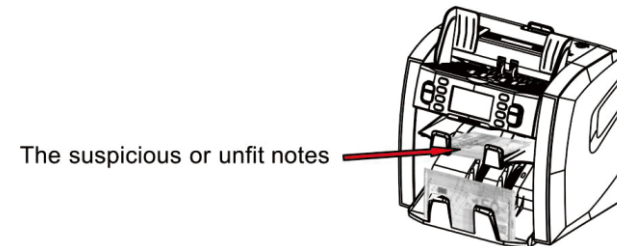


Figure 1

Before counting, please adjust the left and right hopper guides to the size of the banknotes to ensure uninterrupted feeding.

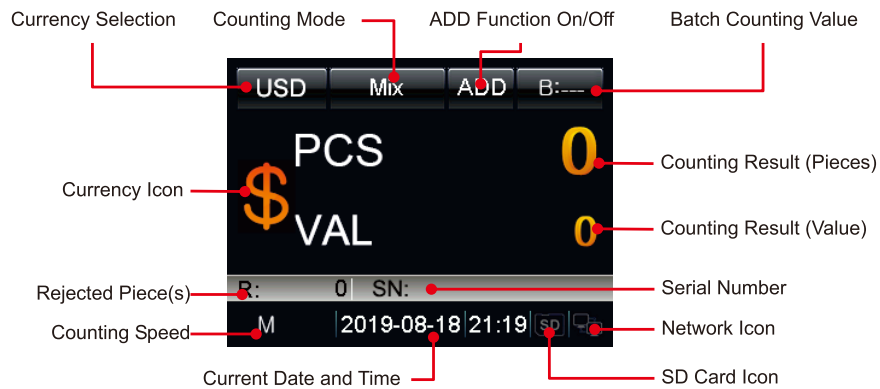


Place the well-stacked banknotes onto the hopper and the machine will start counting. suspicious or unfit notes banknotes will be moved to the reject pocket.



! Note: When an error occurs, and causes the machine to stop automatically, please re-count the banknotes.

Display



Functions

1. Currency Selection

After turning on the machine, the symbol of active currency is displayed on the LCD display. The CR1500 comes with multiple currencies pre-installed.

When you want to count / sort other currencies, press the 'CUR' key until you have found the desired currency.

Notice:

- ❗ When selecting currency, the speed may be set to SPEED L or SPEED M.
- ❗ When "****" is selected, the default setting is SPEED L. Once the type currency is detected (based on the first banknote in the stack), the speed setting is automatically changed to SPEED M, but if SPEED L has been pre-selected at the outset, counting will be done at SPEED L in all modes.
- ❗ If "ALL" is selected, the speed may be set to SPEED L, SPEED M or SPEED H.

2. Counting/Sorting Mode

Five counting/sorting modes are available – Mix mode, Single mode, Face mode, Orientation mode and Count mode. User can press the **MODE** button on the control panel to switch the counting/sorting mode according to requirements.

Definition of Sorting Modes

Mix	<i>Mixed Value Mode</i>	Counts mixed denomination banknotes. Suspicious notes are delivered to the reject pocket.
Single	<i>Single Value Mode</i>	Counts banknotes with denomination of the first detected genuine note. Suspicious banknotes and banknotes with a deviating denomination are delivered to the reject pocket.
Face	<i>Face Sorting Mode</i>	Counts banknotes with the face of the first detected, genuine one. Banknotes with different faces and suspicious notes are delivered to the reject pocket.
Orient	<i>Orient Sorting Mode</i>	Counts banknotes with the orientation of the first detected, genuine one. Suspicious banknotes and banknotes with deviating orientations are delivered to the reject pocket.
Count	<i>Free Count</i>	In this mode the counterfeit detecting function is switched off, the machine counts the number of banknotes without detection.

3. Counting Information

STATISTICS		
Deno	Pcs	Value
1	0	0
2	0	0
5	1	5
10	1	10
20	0	0
USD	2	15

When the counting is completed, the total value and total number of banknotes are displayed on the LCD, and if

the **DISPLAY** button is pressed, the machine will provide a detailed report of counting results. Press **DISPLAY** button again to turn to the next page if there are more denominations on the list.

Rejection List: (001)		
1	IR-Error	0701

Reject Reasons

Press **CUR** or **MODE** to view the reject reason.

4. Print Function

If the machine is connected to the printer, you can print the report by pressing the **PRINT** button.

5. Batch Counting

How to count a preset number of banknotes.

- Press the **BATCH** or the **+1/+10** button to select a batch number.

How to perform batch counting

- Press the **BATCH** button to enter the batch setting interface. Repeatedly press the **BATCH** key to toggle through the various options: 100, 50, 20, 10. Alternatively, enter it via the touch display

(the largest batch number can be set up to 999). Then, press "OK" or **RESET** to save your desired batch quantity.

- You may press the **+1/+10** button to increase the batch number by 1 or 10 notes respectively (the largest batch number can be set up to 999).
- The machine stops once the counted banknotes reach the preset batch number or once the stacker has reached its limit of 200 notes. The counting will continue after removing the notes.

How to cancel the batch function

- When changed to "0", the preset batch number is disabled.
- Press **BATCH** or **CLEAR** to clear the preset value.

6. Cumulative Counting



When you need cumulative counting, press the **ADD** button on the control panel, if "ADD" is displayed

on the LCD, the machine will count starting from the original number displayed on the LCD. When the counting is completed, the number displayed on the LCD is the total value of all consecutive stacks of banknotes. When the total number of banknotes reaches 9999+1, or total value reaches 9999999+1, the number will be reset to 0.



Settings

When the machine is in one of the counting modes, you can enter the user menu by pressing

the **MENU** button. You can navigate to any category by pressing the **ADD** button or

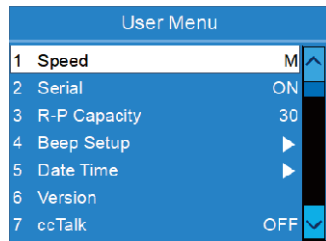
DISPLAY button.

ADD serves as an upward navigation key.

DISPLAY serves as a downward navigation key.

Press **RESET** to confirm. Press **MENU** to exit.

1. Setting Counting Speed



1. Navigate to "1 Speed".
2. Press **BATCH** or **+1/+10** key to select the counting speed.

3. Press **RESET** to save the setting. Press **MENU** to exit.

3 Speed setting available:

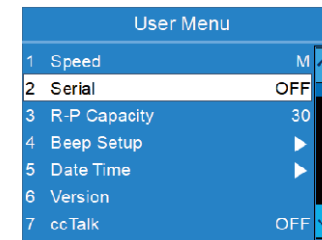
SPEED L - Low speed (800 notes/min)

SPEED M - Medium speed (900 notes/min)

SPEED H - High speed (1200 notes/min)

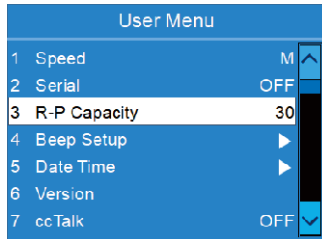
- ❗ Serial number identification function only works with low speed setting (SPEED L).
- ❗ Serial number identification function is available in USD/EUR/GBP only.
- ❗ When a specific currency is selected, the speed may be set to SPEED L or SPEED M.
- ❗ When "****" is selected, the default setting is SPEED L. Once the type currency is detected (based on the first banknote in the stack), the speed setting is automatically changed to SPEED M, but if SPEED L has been pre-selected at the outset, counting will be done at SPEED L in all modes.
- ❗ When selecting "ALL", the speed may be set to SPEED L, SPEED M or SPEED H.

2. Setting Serial Number Identification



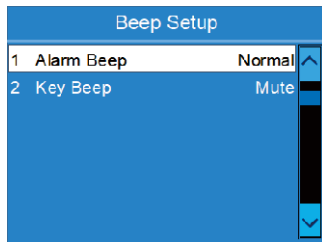
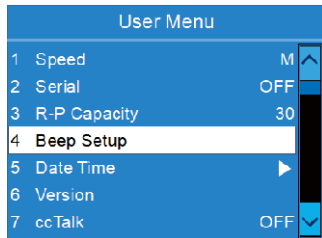
1. Navigate to "2 Serial".
2. Press **BATCH** or **+1/+10** key and select to turn the serial number identification function on/off.
3. Press **RESET** to save the setting. Press **MENU** to exit.

3. Setting Capacity of the Reject Pocket



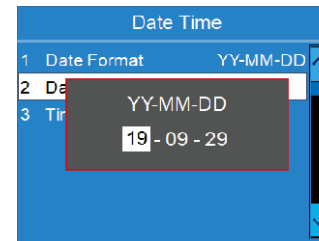
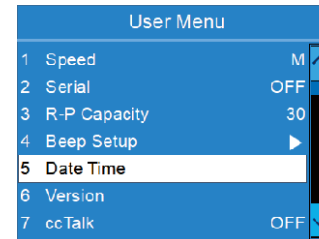
1. Navigate to "3 R-P Capacity".
2. Press **BATCH** or **+1/+10** key to select the capacity of the reject pocket (50, 40, 30 and 20 are available).
3. Press **RESET** to save the setting. Press **MENU** to exit.

4. Setting Sounds



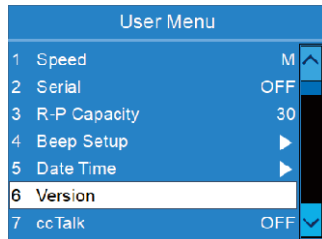
1. Navigate to "4 Beep Setup".
2. Press **RESET** key to enter the sounds setting.
3. Navigate to "1 Alarm Beep", press **BATCH** or **+1/+10** key to switch between "Normal" and "Mute".
4. Press **RESET** to save the setting. Press **MENU** to exit.

5. Setting Date or Time

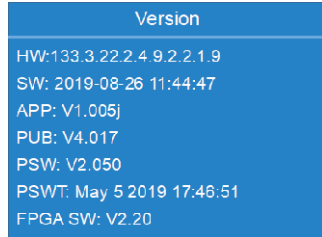


1. Navigate to "5 Date Time".
2. Press **RESET** key to enter the date and time setting.
3. Press **BATCH** or **+1/+10** key to navigate to "Date Setup" or "Time Setup", then press **RESET** key to confirm.
4. Press **BATCH** or **+1/+10** to change the date/time value.
5. Press **RESET** to save the setting. Press **MENU** to exit.

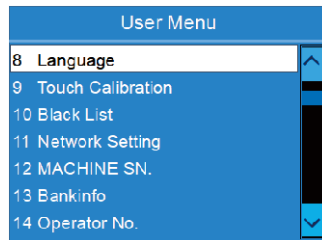
6. Viewing Version Information



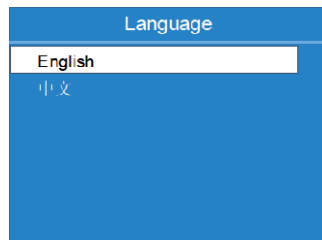
1. Navigate to "6 Version".
2. Press **RESET** key to enter.
3. The version information will show on the screen.
4. Switch to previous or next page via **BATCH** or **+1/+10** key.
5. Press **MENU** key to exit.



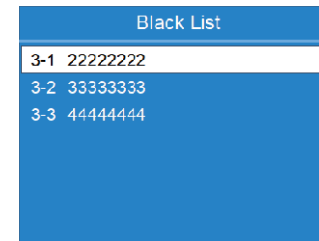
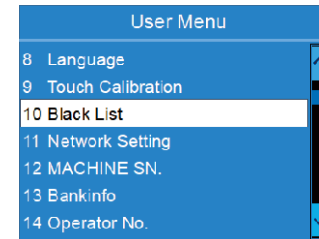
7. Setting Language



1. Navigate to "8 Language".
2. Press **RESET** key to enter the setting of language.
3. Navigate to the desired language.
4. Press **RESET** key to save the setting.

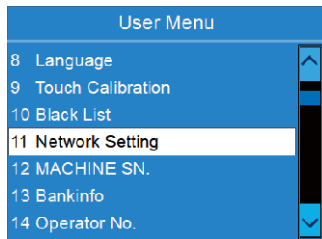


8. Setting Black List Number



1. Navigate to "10 Blacklist".
2. Press **RESET** key to enter the setting of blacklist.
3. Press **PRINT** key to enter to add a new list. Then input the information via the touch keyboard. Press **PRINT** key to switch letters between uppercase and lowercase. Press **↑** or **↓** key to switch to another keyboard interface. The "*" symbol on the last page is used as a wildcard. Use it to replace the letter or number you do not want to match.
4. To edit a list, navigate to it and then press **RESET** key, then edit it via the touch keyboard.
5. Press "OK" button or **RESET** key to save the setting.
6. To delete a list, navigate to it and then press **CLEAR** key.

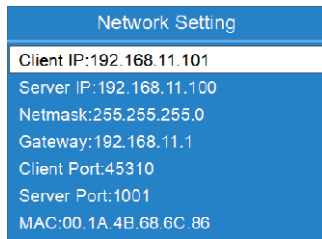
9. Setting Configuring Network (Optional)



1. Navigate to "11 Network Setting".

2. Press key to enter.

3. Navigate the desired item, then press key to confirm.

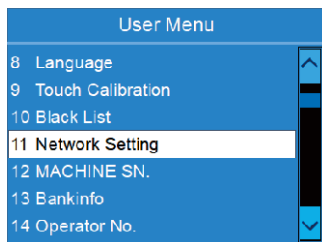


4. Input the number via the touch keyboard. Press key to switch letters between uppercase and lowercase.

Press or key to switch to another keyboard interface.

5. Press key to save the setting.

10. Setting Machine Serial Number



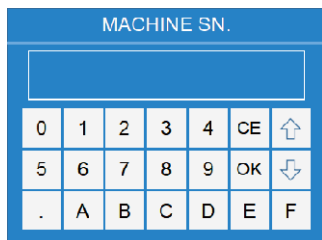
1. Navigate to "12 MACHINE SN.".

2. Press key to enter.

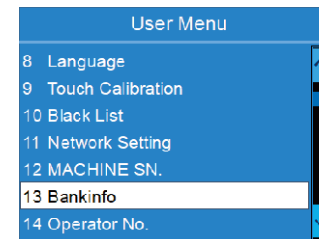
3. Input the number via the touch keyboard. Press key to switch letters between uppercase and lowercase.

Press or key to switch to another keyboard interface.

4. Press key to save the setting.



11. Setting Bank Information



1. Navigate to "13 Bankinfo.".

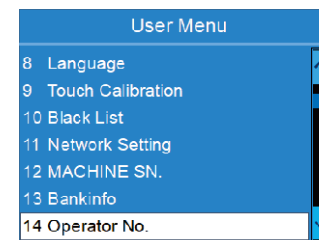
2. Press key to enter.

3. Input the information via the touch keyboard. Press key to switch letters between uppercase and lowercase. Press or key to switch to another keyboard interface.

4. Press key to save the setting.



12. Setting Operator Number

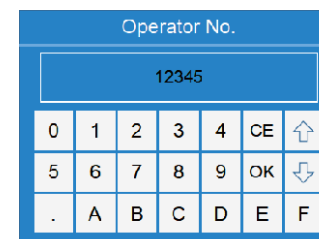


1. Navigate to "13 Bankinfo.".

2. Press key to enter.

3. Input the information via the touch keyboard. Press key to switch letters between uppercase and lowercase. Press or key to switch to another keyboard interface.

4. Press key to save the setting.



13. Setting Sensitivity Parameters

You may encounter the following problems during counting/sorting:

- Machine doesn't sort the notes properly
- Machine frequently recognizes good notes as unfit notes

Please contact your technician/dealer to have the machine's sensitivity parameters adjusted.

In case of a technical problem that can't be solved by operator, please contact your supplier.

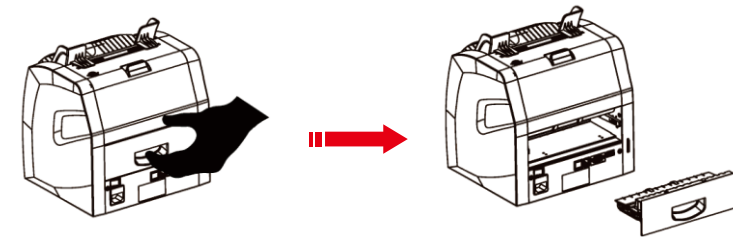
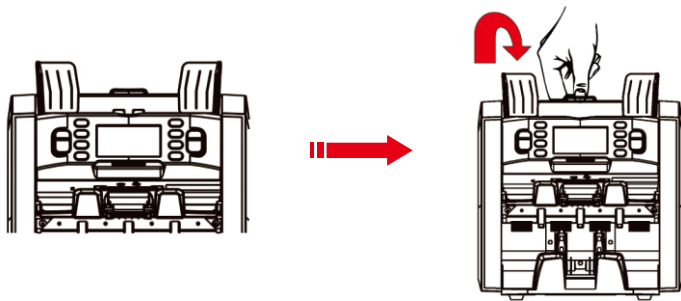
Maintenance

1. Cleaning the Device

For optimal performance the machine needs to be cleaned regularly. Clean the hopper and stacker with the enclosed brush.

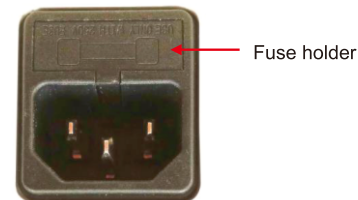
2. Cleaning the Banknote Transport System

- 1 Open the upper back panel.
- 2 Gently wipe the banknote pathway with a small, soft brush or a dry, soft, lint-free cloth.
- 3 If dirt remains, slightly moisten a soft cotton cloth with distilled water or a 50/50 distilled water/isopropyl alcohol solution and wipe the banknote pathway and the sensor surfaces again. Do not let any liquid drip into the device.
- 4 Repeat steps 1-3 to clean the banknote pathway of the lower drawer.



Replacing the fuse

WARNING: To avoid risk of electric shock, always disconnect the main power cable before removing the fuse holder.



If the machine doesn't turn on, it may be caused by a burnt fuse. Open the fuse cover holder and replace the fuse.

Note: To protect against malfunction, replace only with same type and resistance fuses.

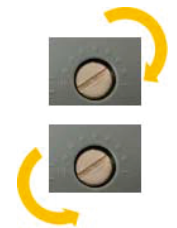
Adjusting feeder's aperture

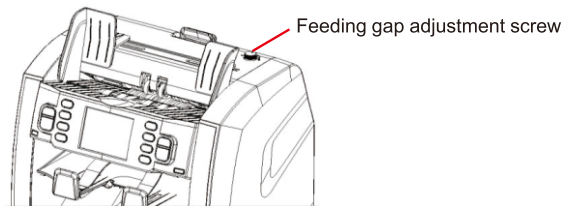
The adjusting screw of the feeder aperture on the top cover has already been set at the factory. You may need to adjust the feeder aperture if the following problems occur during counting/sorting:

- Frequent jams or banknotes pass the feeder with difficulty – turn the adjusting screw clockwise to make the aperture wider.
- Frequent "double notes" or "chained notes" error message – turn the adjusting screw counter-clockwise to make the aperture smaller.

To test it, place a banknote between the wheels in the hopper to imitate banknote feeding and keep hold of it. If you feel the pull on the banknote when wheels are turning, the machine is workable.

Note: The adjusting screw is very sensitive. Move only one notch at a time!





Software Update

The device can be updated via SD card or USB connection. Please contact your dealer for further instructions.

Specifications

Counterfeit Detection:	IR, MG, MT, CIS, UV, etc.
Counting Speed:	800 / 900 / 1,200 notes per minute
Hopper Capacity:	500 notes
Stacker Capacity:	200 notes
Reject Pocket Capacity:	50 notes
Power Supply:	100~240V AC, 50/60 Hz
External Interface:	RS232, RJ-11, USB, SD Card, LAN(optional)
Dimensions:	14.6"(L)*13.4"(W)*15.6"(H) / 370(L)*340(W)*395(H)mm
Weight:	19.8lb / 9kg

Appendix Error Message

Part 1 Self-test error messages and solutions

Error message	Solutions
AD Fault	Restart machine.
Left BackIR Fault Right BackIR Fault	Remove the banknote from the back drawer and/or remove dust from group C IR sensor.
Auto Adjust IR Fault, Please Clean Counting Sensor!	Remove the banknote from the stacker and/or remove dust from all the IR sensors in the path.
Feeding Fault	Remove the banknote from the feeder and/or remove dust from feeding sensor.
Receiving Fault	Remove the banknote from the stacker and/or remove dust from receiving sensor.
Rejector Fault	Remove the banknote from the reject pocket and/or remove dust from reject sensor.
UV Fault	1. Put the machine in a suitable place to avoid strong light on the top cover. 2. Remove the banknote from the machine and/or remove dust from UV sensor.
Left#1 Counting Fault Left#2 Counting Fault Right#1 Counting Fault Right#2 Counting Fault	1. Remove the banknote from the machine and/or remove dust from group BX IR sensor. 2. Restart the machine.
Left CIS IR Fault Right CIS IR Fault	Remove the banknote from the machine and/or remove dust from A. IR sensor.
Rotate#1 Speed Fault Rotate#2 Speed Fault	Remove dust from rotate speed sensor.
CIS#1 Fault CIS#2 Fault	Remove the banknote from the machine and/or remove dust from CIS sensor.
Diverter #1 Fault Diverter #2 Fault Diverter #3 Fault Diverter #4 Fault	Please contact your dealer to adjust the commutator.

Error message	Solutions
Please Clean Left Counting Sensor! Please Clean Right Counting Sensor!	Remove the banknote from the machine and/or remove dust from BX IR sensor.
MG# 1 Fault MG#2 Fault MG#3 Fault	Please contact your dealer for further assistance.
MG#4 Fault MG#5 Fault	Please contact your dealer for further assistance.
MG#6 Fault MG#7 Fault MG#8 Fault	Please contact your dealer for further assistance.
MID-MT Fault	Please contact your dealer for further assistance.

Part 2 Detection error messages and solutions

If the following error message is displayed on the LCD during counting, you can handle them as per the following solutions after the machine is stopped.

Error message	Solutions
Chained#1 Chained#2 Chained#3 Chained#4 Chained#5	1. Some banknotes are attached to each other or overlapping. 2. Place the banknotes from the stacker back to the hopper and re-count. 3. If frequently displayed, turn the adjusting screw anti-clockwise to make the gap smaller.
Double	1. Some banknotes are attached to each other or overlapping. 2. Place the banknotes from the stacker back to the hopper and re-count. 3. If frequently displayed, turn the adjusting screw anti-clockwise to make the gap smaller.
Composed-Error	The banknote is a splicing one. Remove the banknotes.

Error message	Solutions
Corner Folds Count Error Crumples Deinked Fold Graffiti Holes Image Image#1 Image#2 Image#3 Image#4 Image#5 Image#6 Image#7 Image#8 Image#9 Limpness Mutilation Repairs Soiling Stains Tears	1. Select the right currency (the same type as the currency you are counting). 2. Please contact your dealer to do the calibration.
Deno Diff Face Diff Old Ver Orient Diff SN Invalid SN Repeat SN-Error Ver Diff	Remove the banknotes and re-count.
Half	The banknote is in half. Remove the banknotes.

Error message	Solutions
IR-Error IR1-Error IR2-Error IR3-Error IR4-Error IR5-Error IR6-Error IR7-Error IR8-Error IR9-Error	10. Remove the banknotes and re-count. 11. Please contact your dealer to do the calibration.
Length	1. Remove the banknotes and re-count. 2. Please contact your dealer to do the calibration.
Width	1. Remove the banknotes and re-count. 2. Please contact your dealer to do the calibration.
MG-Error MG1-Error MG2-Error MG3-Error MG4-Error MG5-Error MG6-Error MG7-Error MG8-Error MG9-Error	1. Remove the banknotes from the machine and /or remove dust from magnetic sensor. 2. Please contact your dealer for further assistance.
Others Slant Slant#1 Slant#2 Slant#3 Slant#4	1. Titled banknotes. 2. Ensure the banknotes are not being fed straight through the machine. Ensure the banknote are placed neatly and are inserted centered on the hopper. 3. Use the hopper guides to center the banknote when counting a large stack of banknotes.
Thick	Check if two notes are attached.
UV-Error	1. Remove the banknotes from the machine and /or remove dust from UV. 2. If the error persists, please contact your dealer to do the calibration.

Part 3 Alarm messages and solutions

If one of the following error messages is displayed on the LCD during the counting/sorting, refer to the list below:

Error message	Solutions
Bat Full	Counting result reaches preset batch value. Remove the banknotes from the stacker.
Stacker Full	Capacity of stacker is full. Remove the banknotes from the stacker.
Rejector Full	Capacity of reject pocket is full. Remove the banknotes from the reject pocket.
Cover Open	1. Close the top cover. 2. If the top cover is not open, there may be a note inside the machine, remove it.
Back Drawer Open	Close the back drawer.
JAM	Some foreign substance falls inside the machine or notes are blocked, open the back cover to remove them.
Mainloop Broken	Turn off the machine and restart it.
Check Stacker	Remove the banknotes from the stacker.