

Smart Aroma Diffuser User Manual

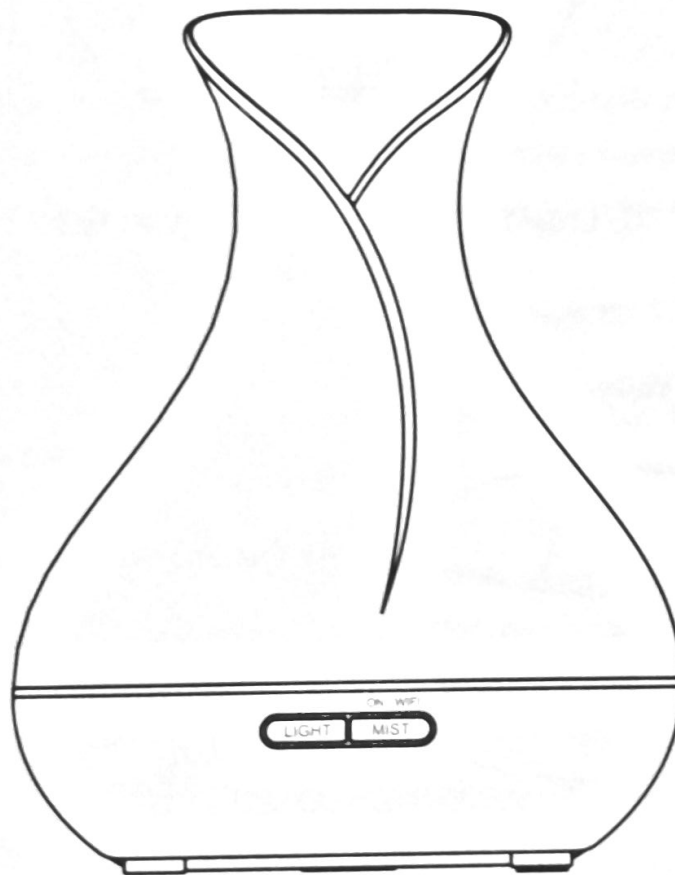

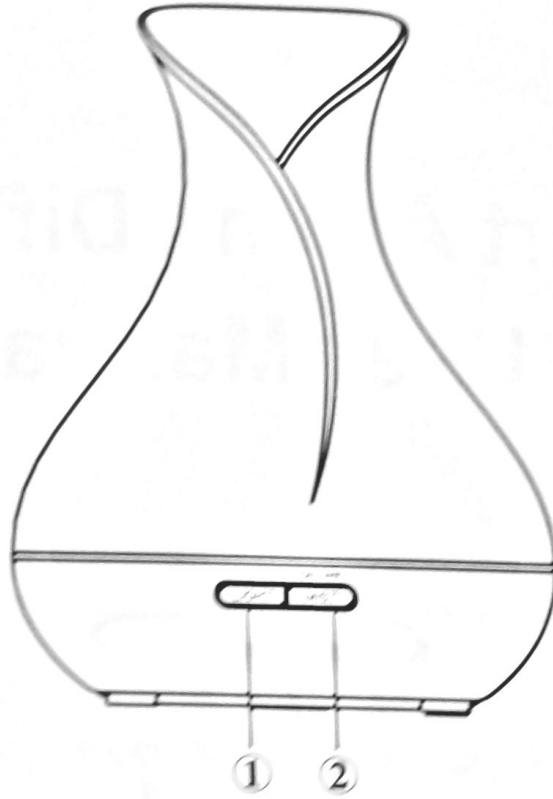

① LIGHT

② WIFI/MIST

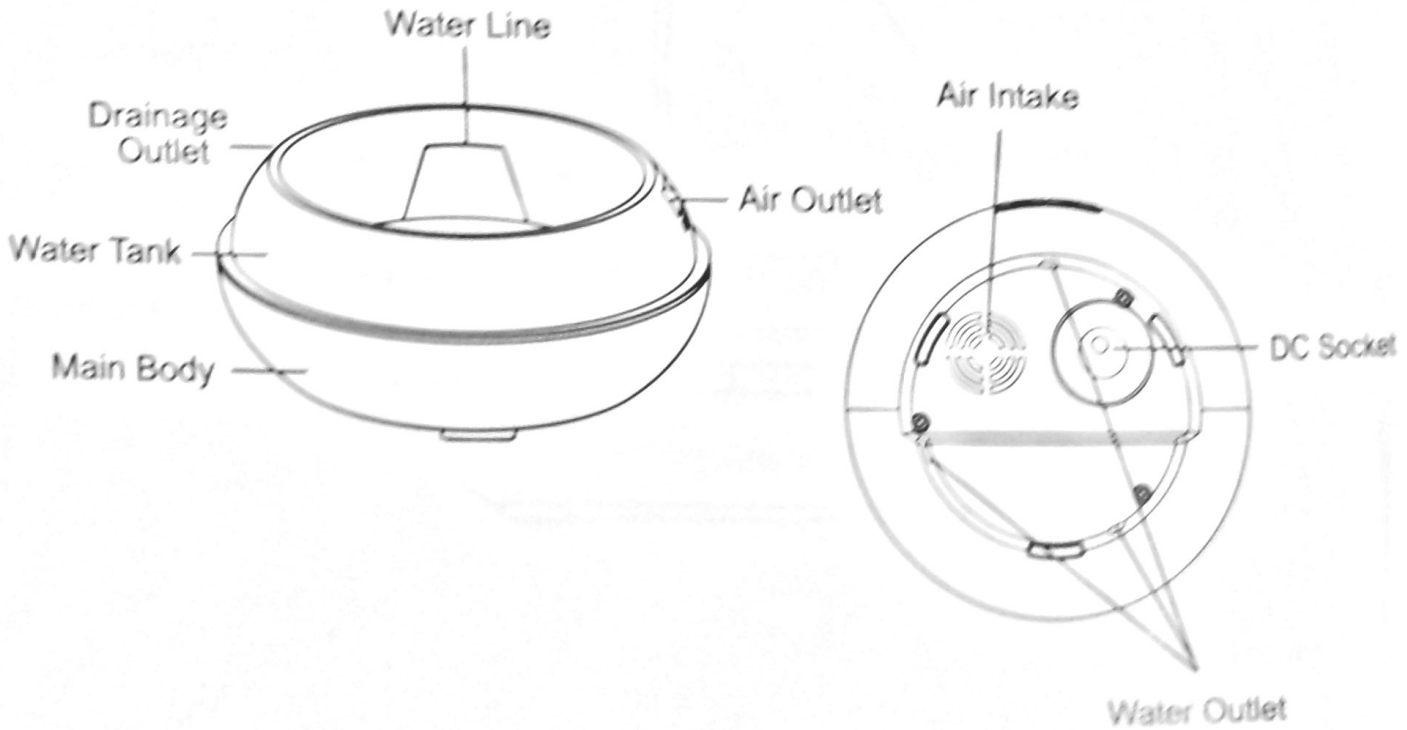

Diffuser Operation

1. Position the Aroma Diffuser upright, pull vertically upwards to remove cover. (Fig. 1)
2. Connect AC adaptor power cord into the DC input jack at the base of the Aroma Diffuser. It is suggested to route cable via track provided. (Fig. 2)
3. Pour water and essential oil into Aroma Diffuser. DO NOT fill in excess of 'MAX' marking 400ml. DO NOT use boiling water. DO NOT fill when power is on. It is recommended to add 2-3 drops of essential oil for each 100ml of water. (Fig. 3)
4. Re-install cover. Spout is adjustable to guide aroma into desired direction. Aroma Diffuser must NOT be operated without the cover. (Fig. 4)
5. Plug diffuser into power outlet.
6. "LIGHT" button--colorful light function: (Fig. 5)
 - 1) Press "LIGHT" turn on LED light. Light color cycles automatically.
 - 2) Pressing the light button again will lock it to the first color. Keep pressing to cycle through colors. Brightness is adjustable through the cycle until it is off. (Bright->Dim->Off)(Press once, beep once).
 - 3) To turn off the light, press and hold down "LIGHT" button for 1.5 seconds. (Two beeps)
7. "MIST" button(WIFI pairing button): (Fig. 6)
 - 1) Mist level is adjustable by pressing "MIST" for different times. Press once, low mist. Press twice, high mist.
 - 2) WIFI pairing function: Press and hold down "MIST" button, WIFI connection mode is on. After two beeps, the "NET_LED" indicator light flashes at a regular way: two times fast, one time slow which shows the diffuser is into WIFI pairing mode.
8. Matching function: (Fig. 6)
 - 1) long press the fog key to enter the WIFI module connection mode. After the buzzer BIBI two, wait for the NET_LED indicator light two fast and slow to have a regular flicker, then enter the WIFI matching mode;
9. It is recommended to drain water from tank and keep dry for extended idle period.
10. When connect with power, the original state of aroma diffuser is still off.
11. Misting operation and light will switch off automatically when there is insufficient water, even press "MIST" , aroma diffuser is also switch off automatic.



Fig1

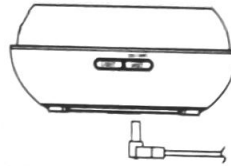

Fig2



Fig3

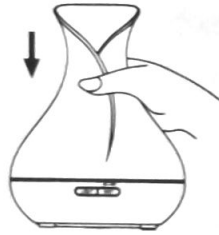

Fig4

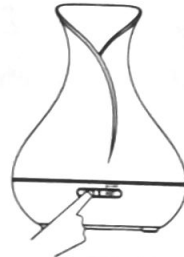

Fig5

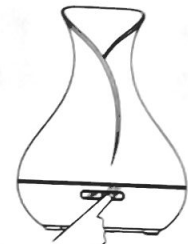

Fig6

Attention

- The amount and intensity of mist produced will vary, but this is not unusual and should not be considered as a fault.
- Factors that affect this include water type, humidity, temperature, air currents.
- Auto power off when water runs out.
- Applies only 100% natural essential oil, if they contain chemical ingredients, flavors or impurities may cause damage to the product.
- Before replacing another essential oil, follow the maintenance part to clean the product.

Accidental Leakage

In the event of the unit being knocked over or tipped during use, please follow the steps as below to avoid malfunction:

1. Unplug the unit and remove cover.
2. Pour out any remaining water from the water tank.
3. Shake the unit gently to drain water, and then keep it natural air drying for at least 24 hours.

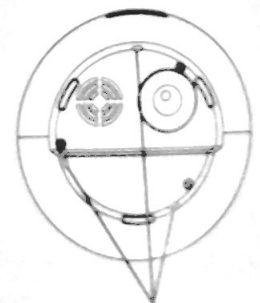
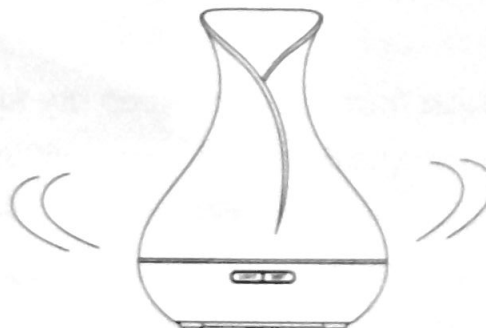

Water Outlet

Maintenance

After using 5-6 times, or 3-5 days, please clean the product as follow:

1. Unplug the unit and remove cover.
2. Pour out any remaining water from the tank.
3. Add a small amount of warm kitchen detergent to clean, use swab to wipe it gently, and then use cleaning cloth to dry it lightly.
4. Refer to the following pictures, to avoid water flow into the air outlet, pour off water abide by the left picture, not the right one.
5. Do not use other acids or enzymes detergent, as this may give off poisonous gas or cause malfunction.

Note: Be sure to use a mild detergent.

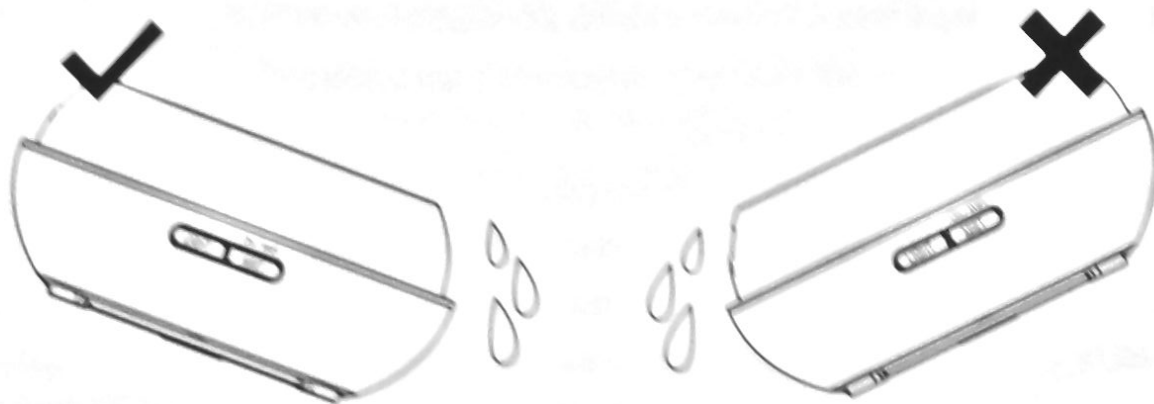

Precautions

- It is not allow to change, dismantle, or repair the unit if you are not the technician. Please contact the selling department to repair if necessary.
- Do not switch on power when the tank is empty.
- Do not touch the atomization piece.
- Clean regularly as per Maintenance instructions to avoid malfunction.
- Always unplug before maintenance.
- For hygiene reasons, after use, pour away remaining water from "DRAINAGE SIDE" of tank, and wipe with a clean dry cloth.
- Essential oil can corrode in the event of spillage of contact, please wipe away with a soft cloth.
- Only use the measuring cup to add water into the tank, do not fill water directly from the water pipe.
- Do not let mist directly to the furniture, clothing, walls etc.
- Keep away from direct sunshine heat sources and air conditioners or fans.
- Always keep on stable flat surface do not put on carpet, duvet or unstable area.
- Keep away from electronic equipment, such as TV and Audio equipment.
- Wait 60 minutes before restart to avoid damage atomization piece.
- Don't use sparkling water, tap water and mineral water are available.
- Never move product when it is working.
- Do not touch any part of the product with wet hands.
- Keep away from the child and pet, child is not allow to play without supervisor. This product is not suitable for the child and people who don't know the product and have no experience.
- If the cable is smoking, burning, unplug immediately.

Troubleshooting

Please refer to the table below in the event of the product operating abnormally:

If product doesn't work well, please refer to the following points before requesting repairs:	
Will not switch on or switch off	<ul style="list-style-type: none">● Is there enough water in the tank? --Please add water to the tank● Is the power cord connected property? --Please disconnect, check cables and re-connect carefully.
No mist or abnormal mist	<ul style="list-style-type: none">● Not enough water? or too much water? --Please add suitable amount of water in the tank, water must never be filled over 400ML (MAX)line.● Dirt on the atomization piece? --Please refer to maintenance instructions remove and re-install correctly, so mist can be released freely.● Cover and inner cover are not installed properly? Dirt on the air suction port on the underside of the base? --If too much dust in the air suction port, the mist will be restricted to come out. Just clean it.
Water leakage from product	<ul style="list-style-type: none">● Cover and inner are not installed properly? --Remove and reinstall correctly, so mist can be released freely.● Low temperature or high humidity? --Under these conditions, the mist may condense quickly into water droplets.

Specifications

Dimensions	Approx 168.5 x 215MM
Weight(excluding adaptor)	Approx 468g
Power: Input/Output	AC100-240V 50/60Hz DC24V 650mA
Length of cord	Approx 170CM
Power	Approx 14W
Tank Capacity	400ML
LED light	3pcs
Material	PP/ABS
Accessory	AC Adapter and manual
Working frequency	2.4MHz

App Connection Guide

Download TuyaSmart from App Store or Google Play. TuyaSmart



TuyaSmart



Register and log in:

Register a new account via mobile phone number or email, setting password as letters with numbers (password must longer than 6 letters and less than 20).

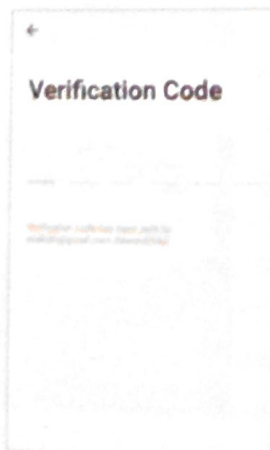

Click "Add Home" to create a customized operation system.

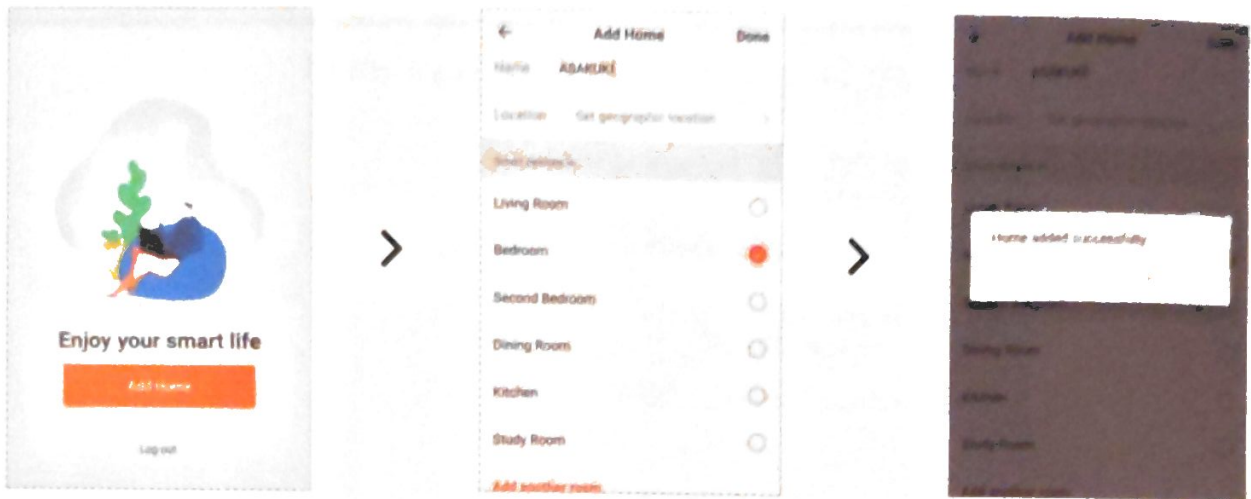

Then "Add device", select device type as "all", Choose "Air Purifier" or "Water Purifier" or "Humidifier", Click "Confirm indicator rapidly blink", then enter your Wi-Fi password. Wait till the circle 100% completed. Now you can name your diffuser and control it via APP.

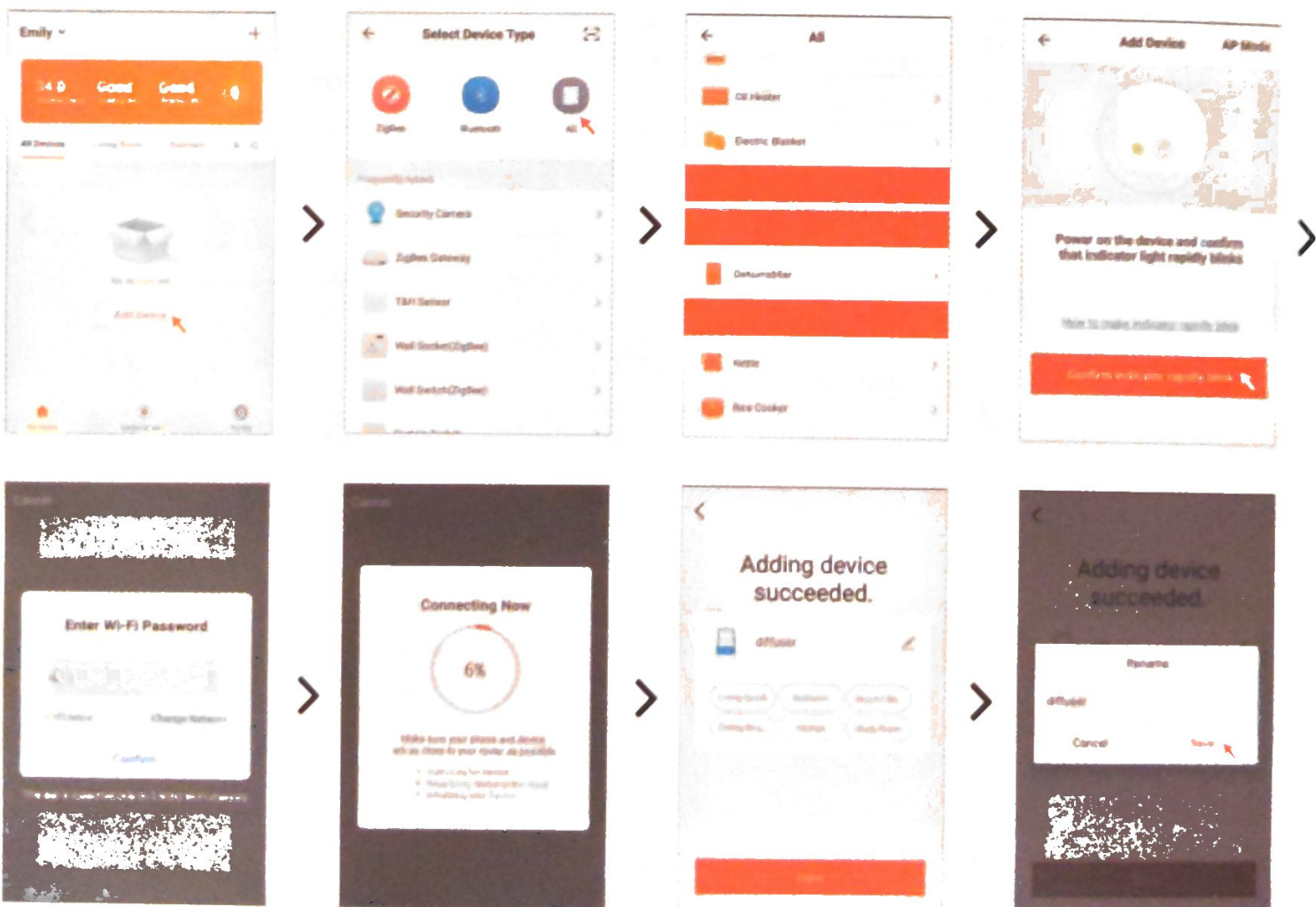

APP Control Guide



Click Power to turn on/off both the light and the mist.



Click Spray to control mist.
Spray Mode:
Weak Mode & Strong Mode
Spray Timer: ON/1H/3H/6H



Click Light to control light.
Gradient: Light color will cycle automatically.
Fixed: Fix one color and brightness adjustable.
Nightlight:
Fix at green light and brightness adjustable.

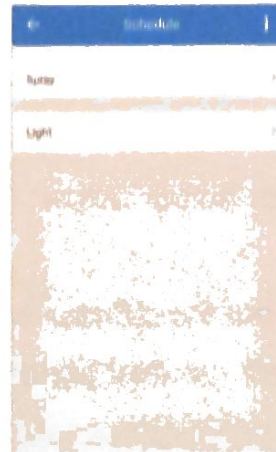

Click Schedule to set mist or light schedules.

Note & QA

Note

- In order to pairing successfully, it's better to operate near the WIFI router. If your home Wi-Fi does not require a password, leave it blank.
- The device only supports 2.4GHz networks. 5GHz network is unavailable.
- If Failed to Add, please unplug the diffuser for 2 minutes and try again.

QA

Q: Router can not access the Internet, dose it support the local area network? Can it directly connect to cellphones hot spots?

A: The Android version supports LAN control, while Apple version currently not. The device must be connected to the Internet via a router to communicate with the mobile server.

Q: Why can not I get a registered SMS verification code? Why can not mobile phone connect device hotspot?

A: Permission is limited. Select "Allow" when you encounter authorization during installation.

Q: My router is 5GHz, but the diffuser only work with 2.4GHz, can I connect with this diffuser?

A: Yes, some routers will run dual band by default - both 5.0GHz and 2.4GHz.

In this case, there are two steps you need to do as follows:

- Disable 5.0 GHz frequency (temporarily)
- Set up a guest network

After doing both these things, the device will pair correctly and you can re-enable the 5.0GHz frequency without any other influence.

Amazon Echo Connection

Compatible with Amazon Echo

- Download and install Alexa app.
- Register an Alexa account and pair your Echo.
- Add TuyaSmart skill.

Click menu at the upper left corner



Click Skills to enter skill store.

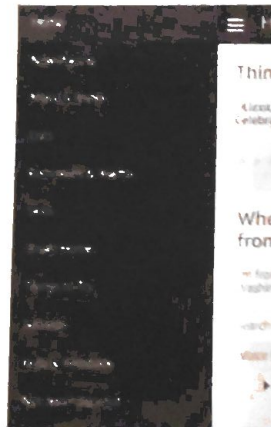

Search TuyaSmart

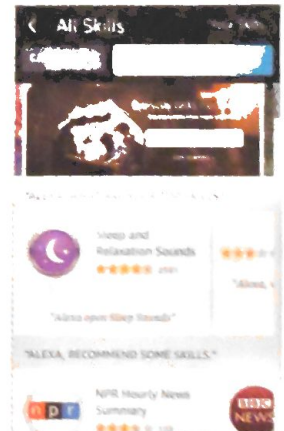

Click Profile and Settings.

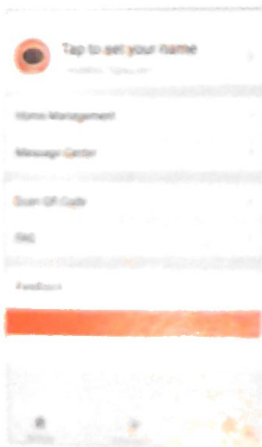

Click Integration.

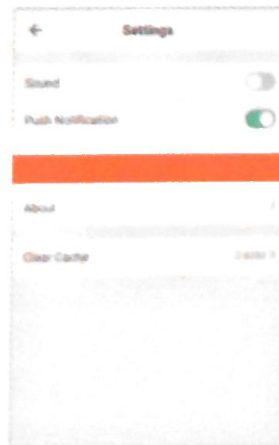

Choose amazon alexa.

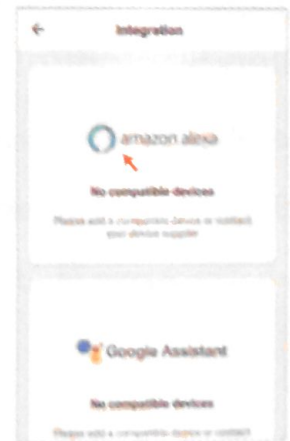

Follow the steps to connect with Alexa.

Step 1: Add Device

Make sure there is at least 1 device that is supported by Amazon Alexa. This is shown on the Integration Screen.

Step 2 : Modify Device Name

Modify device name so your Amazon Alexa can easily recognize the name. For Example: Living Room Lamp, Bedroom Light.

Step 3 : Set Up Alexa

Use Alexa App or Computer (<http://alexa.amazon.com>) to set up your Amazon Alexa.

Step 4 : Add Skill

In the menu bar, go to "Skills" and search for "Tuya Smart". Enable Skill, then type in your login info from your app account to finish the account linking.

Step 5 : Control Device

Ask Alexa to discover devices. After 20 seconds, devices will be discovered and Alexa will tell you " I found x devices". Then you can control your devices using voice through your Amazon Alexa product.

After completing, enjoy your smart home journey.

Or, you can search devices by the following orderings:

* Alexa, discover my smart home devices.

* Alexa, discover device.

* Alexa find device

After 20 seconds, echo will tell you how many devices it found.

Sign in Alexa app and click Smart Home to control the devices it found.

Operational Orderings.

(Make sure device name is English and don't use special characters that device cannot recognize.

Such as: My lamp, Switch, My switch, etc.)

Searching Devices:

"Alexa, discover my smart home devices"

Device On/Off Orderings:

"Alexa, turn on diffuser"

"Alexa, turn off diffuser"

Color Setting:

"Alexa, turn diffuser to red (white, green, yellow, blue, purple, orange)"

Percentage Setting - LED Brightness Adjustment:

"Alexa, set diffuser to 10 (20, 30, 40, 50, percent)"