



QuantAsylum QA401 User's Manual
192Ksps 24-bit Stereo Audio Analyzer

Revision 1.908

May 2020

Safety Notice

- ❖ This device is not designed for working on potentially dangerous voltages.
- ❖ This device is not designed for working on high energy circuits.
- ❖ The maximum DC input voltage is +/- 5V into the device inputs.
- ❖ The maximum AC input voltage is +/- 50V into the device inputs.
- ❖ See additional safety notices throughout this document.

Limited Warranty

This product has a limited warranty for 6 months from the time of purchase. During this time, a device failure that occurs under normal operating conditions will be replaced or repaired for free, not including shipping. Generally, you will be responsible for shipping to us, and we will be responsible for shipping it back to you.

Devices that have suffered a failure due to operation in excess of specified parameters can usually be repaired for a nominal fee.

The contents of this document are provided "as-is" and may be changed or updated without notice. The specifications on a particular product may also be changed at any time and without notice as we seek to improve a product or improve availability of a product.

The limit of our warranty will not exceed the value of the product purchased under any conditions.

QuantAsylum QA401 User's Manual

Contents

Safety Notice.....	2
Limited Warranty.....	2
Legal.....	7
In the Box.....	7
Important Things to Know.....	7
Ground Reference.....	7
BNC Input Voltages.....	7
BNC Output Voltages.....	7
QA401 Output Voltage Offsets, Clicks and Pops.....	7
QA401 Analyzer Features.....	8
Analyzer Front Panel.....	8
Front Panel Summary.....	8
LEDs.....	9
BNC Inputs.....	9
Understanding Differential Measurements.....	9
Rear Panel Summary.....	10
Electrical Characteristics of the Connectors.....	10
BNC Inputs.....	10
BNC Outputs.....	11
USB Input.....	11
Software Installation.....	11
Calibration.....	11
Verifying Accuracy.....	12
Calibration Adjustments.....	12
Attenuator Adjustments.....	13
QA401 Basic Controls.....	14
Up/Down Adjustments.....	16
Context Menus.....	16
Control Overview.....	17

QuantAsylum QA401 User's Manual

Run/Stop Button	17
Display Options	19
Axis	21
dBFS, dBV, and dBr Buttons	21
dBV Context Menu	22
dBr Button and Context Menu	23
X Lin/X Log Buttons and Context Menus	26
Display Panning and Scrolling	27
Titles and Markers	28
Adding Markers.....	29
Acquisition Control	30
Weighting.....	31
Windowing Functions	33
Measurement Types	36
Definitions	36
QA401 Measurement Types	37
RMS/Power	38
THD.....	39
THD Context Menu.....	41
THD + N	43
Frequency Response	43
Generators	47
IMD Measurements	48
Power Supply Noise Measurements	51
Settings.....	52
General.....	52
Display.....	52
Other	53
Setting : Audition	57
Setting : Generate Fixed Tone.....	58
Edit: Copy Bitmap to Clipboard.....	58

QuantAsylum QA401 User's Manual

Edit: Snapshot	58
Test Plug-ins	59
AMP: FREQUENCY RESPONSE	60
AMP: FREQUENCY RESPONSE CHIRP	61
AMP: GAIN AND DISTORTION VERSUS AMPLITUDE	62
AMP: THD(N) VERSUS FREQUENCY.....	63
AMP: THD VERSUS OUTPUT LEVEL	65
DAC: NOISE AND DISTORTION VERSUS OUTPUT LEVEL.....	66
DAC: OUTPUT IMPEDANCE VERSUS FREQUENCY	66
DAC: THD(N) VERSUS OUTPUT LEVEL	67
MIC: CompareToReference.....	68
HEAD: Impedance with QA490	70
PWR: IMD VERSUS OUTPUT POWER	71
PWR: OUTPUT IMPEDANCE VERSUS FREQUENCY	72
PWR: OUTPUT IMPEDANCE VERSUS FREQUENCY 450	74
PWR: THD VERSUS OUTPUT POWER	74
SPKR: CHIRP COMPRESSION	76
SPKR: SPEAKER IMPEDANCE	78
SPRK: Rub and Buzz.....	80
Keyboard Shortcuts.....	80
Appendix 1: Troubleshooting.....	82
Connectivity Issues.....	82
Appendix 2: Visualizers	87
Background	87
Appendix 3: Software API	89
Overview	89
Appendix 4: Regulatory Notice	92
Overview & Safety	92
Environmental.....	92
Power Supply	92
Shock Hazard.....	92

QuantAsylum QA401 User's Manual

FCC	92
EU Emissions	92
EU Safety	93
EU Waste Electrical and Electronic Equipment Directive	93
Appendix 5: Specifications	94

QuantAsylum QA401 User's Manual

Legal

This document and the associated computer codes, hardware design and hardware configuration files are copyright © 2011 - 2019 by QuantAsylum USA LLC. All rights are reserved. You may share the associated documents in PDF format freely. The EXE programs and code in the developer section is for use only with QuantAsylum products. The hardware and software designs are protected and the property of QuantAsylum USA LLC.

In the Box

Your new analyzer should contain the following:

- QA401 Audio Analyzer
- Certain product variants may contain cables. But we're moving towards NOT shipping common cables & accessories with products any longer. Please see the [QA401 product page](#) for links to common connectors you may need.

Installation software, this manual, and application notes for the analyzer are available on the web at <http://www.QuantAsylum.com> in the Support section.

Important Things to Know

Ground Reference

The analyzer PC interface will share a ground with the PC. The audio inputs and outputs, however, are isolated from the PC. This isolation is limited to 50V. Do not connect the QA401 to a product that has its ground reference more than +/-50V from the PC ground.

BNC Input Voltages

The AC input to the analyzer should never exceed 56 Vpp (single ended) or 28Vpp (differential). The DC limits are lower. DC voltages above +/- 6V with the attenuator disengaged may permanently degrade the performance of the device. In general, we recommend a DC limit of +/-5V regardless of attenuator setting. If you need to measure power supply noise, see the section in the manual on how to safely do so.

BNC Output Voltages

The BNC output connectors have a 47 ohm limiting resistor and thus have minimal protection. If you accidentally connect a voltage of more than few volts to the outputs, you may damage the output stage by opening these resistors.

QA401 Output Voltage Offsets, Clicks and Pops

The QA401 output voltages will nominally have an offset of 1-2 mV. If you wish, you can trim those offsets to microvolt levels through the Settings->Options->Other->Trim menu. However, be aware that certain operations on the QA401 can generate clicks and pops and also modify offsets. This is especially true when using external programs to control the QA401.

QuantAsylum QA401 User's Manual

Also, when changing the sample rate on the QA401, the codecs will be reset to ensure proper application of their changed register settings. That will also generate a click or pop on the outputs. Normally, these clicks and pops won't present issues. But if you are working on very high-gain stages with speakers or headphones attached, first take the time to familiarize yourself how the various mode changes may impact your equipment under test.

QA401 Analyzer Features

The QA401 is our second-generation audio analyzer. Our goal in building the QA400 and the QA401 was to leverage modern ADC and DAC codecs commonly used for audio analysis, while at the same time eliminating some of the bigger problems that come with re-purposing audio ADCs for audio measurement.

The QA401 Features:

- Stereo differential LEFT + RIGHT inputs
- Stereo differential LEFT + RIGHT outputs
- 24-bit ADC and DAC
- Fully isolated from the PC
- Input attenuator and hardware-based overload protection
- USB powered

We hope you enjoy your purchase! Check back from time to time for new software updates. If you have any questions, please send them to support@QuantAsylum.com. We welcome all questions, no matter how simple.

Analyzer Front Panel

This section covers the various connectors on the analyzer and reviews the input and/or output characteristics of these connectors.

Front Panel Summary

The front panel of the QA401 is shown in the picture below. From left to right, the following entities are explained.

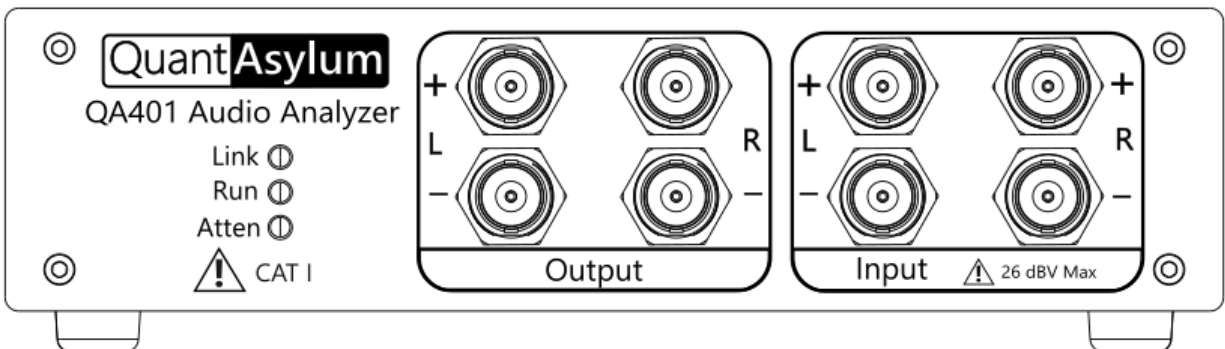

QuantAsylum QA401 User's Manual

LEDs

- Link LED** This LED indicates the analyzer is connected to the PC and talking to the analyzer application.
- Run LED** This LED indicates the analyzer is currently running (acquiring) data.
- Atten LED** This LED indicates the internal 20 dB attenuator is active. The attenuator is active when the device is unpowered. The device can withstand the rated AC voltages when unpowered.

BNC Inputs

There are two stereo inputs (Left and Right) and two stereo outputs (Left and Right). Each input and output is differential. This means the magnitude of the + and – signals are equal and opposite. For example, if you were to look at the output signals on an oscilloscope, you'd see that when the L+ output was sweeping a sine wave with a peak of +3V, the L- output would be sweeping a mirror image sine wave with a peak at -3V at the same instant. Differential signals are commonly used in noisy environments because interfering signals that appear on both inputs simultaneously are “cancelled” or at least greatly attenuated. However, for much of your audio work, you may prefer to use the device in single ended mode especially if you are working on line-level consumer audio type equipment.

If you wish to use the inputs single ended, then you could use a BNC terminator on the L- input, and treat the L+ input as a single ended input. If you do not use the input terminator, then you will see some thermal noise from the unused input resistor, which will raise the overall noise floor. See the [QA401 product page](#) for links to suppliers of these common connectors.

Understanding Differential Measurements

Differential measurements can create confusion even among very experienced engineers. Some examples will help highlight the differences.

If you set the generator to 0 dBV and connect an Output+ to an Input+ and ground the Input- via BNC terminator, then the measured input will be reported as 0 dBV.

With the output set to 0 dBV, each output will measure 1Vrms on a DVM relative to ground (the BNC outer conductor). A differential measurement on a DVM (from Out+ to Out-) will measure as 2Vrms. This is because the Out+ and Out- are 180 degrees out of phase with each other.

If you set the output to -10 dBV and connect both the Out+ and Out- connectors to the In+ and In- connectors, then the QA401 measurement will show a peak of -4 dBV. This is because you are driving the inputs differentially. *This can be very confusing to first-time users: You are driving the inputs at 100 mVrms (-10 dBV), and yet the QA401 is reporting -4 dBV. But this is precisely the same measurement reported by the DVM when you placed the DVM across the outputs.*

Keep in mind the QA401 inputs have no idea if you are driving a single input with 1Vrms and grounding the other input OR if you are driving both inputs with 0.5Vrms. In both cases, you are hitting the ADC with

QuantAsylum QA401 User's Manual

the same differential voltage. That is, the differential input of the ADC is seeing 0.5Vrms on each input in both cases.

Rear Panel Summary

The rear panel has a single USB connector. This is designed for high speed (480Mbps) USB connections. The device consumes between 500 and 600 mA during normal operation. The device is not sensitive to USB voltage variations, but it can be sensitive to USB voltages that fall below 4.6V as measured inside the QA401. For this reason, use USB cables that are short and have 24g power conductors. You can often read this directly off the side of the USB cable.

Note that some computers may employ very strict current sensing on the USB current flowing out of the USB port. When the current exceeds a bit over 500 mA, the PC hardware might signal a fault. If you suspect your PC has strict limits on the power, then you can use a USB Y connector. These are connectors that plug into 2 USB ports and allow USB hardware to pull up to 1000 mA. One of the USB ports has no data connection. It just takes power from the second port.

Alternately, most low-cost USB hubs that are self-powered do no sensing or limiting at all.

Electrical Characteristics of the Connectors

BNC Inputs

The 4 audio signal inputs pass through a 33uF series capacitor, followed a series 100 ohm resistor, and followed by a resistor divider with a total impedance of 100K ohms. The corner frequency of this input network is about 1.6 Hz.

The input DC blocking capacitor is polarized, with a 50V rating. The DC blocking capacitor can withstand a negative voltage of 15%, or 7.5V, for 125 hours. In general, we recommend you limit the long-term DC level (relative to ground) to just a few volts, keeping in mind that the capacitor will degrade over time depending on the magnitude of the voltage.

The input stage will be clamped to the internal input rails (about +/-6.5V) through the 100 ohm input resistor. The input attenuator is very fast. We've tested overload conditions of 70Vpp for hours on end, with no impact noted to the performance of the device. During overload, the system will detect the excessive input and engage the attenuator. After 1 second, the attenuator will be released, and the input level again checked. This cycle will repeat indefinitely. Of course, the audible indication of the relay clicking every second should alert you that the input voltage is too large and to manually engage the attenuator.

IF YOU GOING TO APPLY A HIGH DC BIAS TO THE QA401 INPUTS, YOU MUST MAKE ABSOLUTELY SURE THE ATTENUATOR IS ENGAGED. SEE THE SECTION ON MEASURING POWER SUPPLY NOISE COVERED IN RMS MEASUREMENTS.

DO NOT EXCEED THE RATED MAX INPUT VOLTAGE OF THE Q401. IT CAN RESULT IN PERMANENT DAMAGE TO THE QA401.

QuantAsylum QA401 User's Manual

NEVER USE THE QA401 TO MEASURE CIRCUITS THAT USE POTENTIALLY LETHAL VOLTAGES.

The default state of the input is that the attenuator is engaged. That is, when the device is unpowered, the attenuator is active. When you first connect the device, regardless of UI setting, the attenuator will remain active (attenuating). And when you close the QA401 application or unplug the QA401 hardware, the attenuator will always re-engage.

BNC Outputs

The output op-amps have a 47-ohm series R in an 0603 form factor. If the output is accidentally connected to a voltage more than few volts in magnitude, the 0603 resistor could act as a fuse and open or the output op-amps could be damaged.

All 4 outputs are DC coupled, with a typical offset between of a few millivolts. Beginning in the 1.5 release of the software, a trim function is provided to allow the user further null the offset. You should be able to achieve a few 10's of microvolts of offset between the differential outputs. See the section on using the trim function for more information.

USB Input

The USB input is designed to operate with the maximum and minimum voltages specified by the USB Implementers Forum, which is 4.75V to 5.25V. The noise performance of the analyzer should be unchanged to down to 4.6V DC. Below that, certain regulators may begin to drop out and noise performance might be impacted.

Do not exceed the USB spec 5.25V upper limit.

Software Installation

The software must be run on Windows 10.

Before plugging in your analyzer, you need to install the software. To do this, download the latest installer package from QuantAsylum.com (see the Support → Downloads page) and run the installer.

The first time you run the installer, you should opt to install the drivers. On subsequent upgrades on the same machine, you do not generally need to run the installer unless it is noted in the release notes.

Once installed, you may plug your analyzer into the USB connection on your computer.

Calibration

The QA400 product, which was the predecessor to the QA401, required calibration by the user. This was because the manufacturing window of the ADC/DAC used could be fairly large (+/-25%). The QA401, however doesn't need calibration and will deliver outstanding accuracy out of the box.

QuantAsylum QA401 User's Manual

Verifying Accuracy

Accuracy should be verified from time to time. The procedure is simple and requires a DVM with trusted accuracy. Generally, quality DVMs will hold their stated accuracy for a decade or more easily because the drift and aging associated with the internal references used are very low. But quality DVM manufacturers will also allow you send in your DVM and have it re-calibrated certified to be operating correctly for a fee.

Using a DVM with a calibration that you trust, perform the following steps:

- 1) Use the Settings → Generate Fixed Tone menu option to generate a 0 dBV signal at 60 Hz. Note the amplitude. It should be 1.000Vrms +/- 4% (0.96 to 1.04Vrms) on all 4 output ports of the QA401. This is a single-ended measurement, with one input to the DVM taken from the center of the BNC, and the other input to the DVM taken from the BCN outer conductor.
- 2) Repeat the measurement used in step 1), except this time generate a 1 KHz signal. Most DVMs will show a very small reduction in reading (few %) between 60 Hz and 1 KHz. This is attributable to the natural roll-off of the meter's response. If your DVM shows more roll-off than a % or two, then make a mental note that your DVM is not suitable for direct measurements at 1 KHz and the calculations below should be adjusted accordingly. Most meters are specified at 60 Hz, and the upper corner isn't generally published by the DVM manufacturers. Thus, it's important to know.
- 3) Cancel the fixed tone generation and connect the + output L of the QA401 to the + input L of the QA401. Short the – input.
- 4) Select File → Reset startup defaults. This will put the analyzer into a known state.
- 5) Set windowing to Flat Top, Atten Off, RMS Measurement, and dBV axis settings
- 6) Set Gen1 to 1 KHz, 0 dBV
- 7) Press the Run/Stop button to start the acquisition and verify the input PeakL is 0 dBV +/- 0.1 dB
- 8) Engage the attenuator. You will see the message "Atten: 20 dB" on the display. Verify the signal is reported as 0 dBV +/- 0.15 dB.
- 9) Activate the Right Channel and turn off the Left channel in the Display Options section of the UI. Repeat the above steps for the right channel.

If your QA401 is operating outside of the windows specified above, then please contact Support@QuantAsylum.com so that we can evaluate this together. Do not rely on the calibration adjustments described below to try and adjust for errors that are larger than expected.

Calibration Adjustments

There is a file that resides in the My Documents folder under the QuantAsylum\QA401 directory. The file is named CalibrationData.xml. The contents of this file are parsed at startup of the QA401 application. Once read, the file isn't needed again until the next re-launch. So, if you ever make manual changes to the file, you must re-launch the QA401 application to re-parse the file.

In general, there shouldn't be a need to make adjustments to the calibration file! This detail is provided here for advanced users with unique requirements, or for users that are interested in eliminating the last 1 percent of error. If you ever doubt the accuracy of the calibration file, just delete it and a new default will be created.

QuantAsylum QA401 User's Manual

There might be a few reasons for making changes to the calibration file. First, you might want to tweak for different output impedances. As the QA401 has a 100K AC input impedance, if you are using a source impedance that is 50 or 100K, then it might make sense to keep a calibration file around for Hi-Z equipment and low-Z equipment. This could be done by renaming the file and swapping names as needed before launching the QA401.

A typical file might appear as follows inside:

```
<?xml version="1.0" encoding="utf-16"?>
<CalibrationClass xmlns:xsi="
http://www.w3.org/2001/XMLSchema-instance" xmlns:xsd="
http://www.w3.org/2001/XMLSchema">
  <InputCalL>1</InputCalL>
  <InputCalR>1</InputCalR>
  <OutputCalL>1</OutputCalL>
  <OutputCalR>1</OutputCalR>
</CalibrationClass>
```

Notice there are 4 numbers: two output numbers, and two input numbers. The output numbers (OutputCal) are the value the output will be multiplied by before being sent to the DAC. If you want to increase your output value by just a bit, you can increase the OutputCal figure by whatever amount you wish.

Similarly, the InputCal is the amount the input will be multiplied by to get it where it needs to be to deliver the precise dBFS level. You may also adjust these values as you see fit. As with the output value, a single calibration value is used for both left and right. You can put in a separate value for left and right if you see fit.

If you corrupt the contents of the file, the QA401 software will be unable to parse the contents and it will create a new file, overwriting the corrupt file.

Attenuator Adjustments

The QA401 attenuator is built from 0.1% resistors and should be nominally 20 dB. The software assumes it is 20 dB precisely, but this can be changed. The real attenuator value may vary +/- 0.06 dB depending on resistor variation. To fine-tune the attenuator, perform the following steps:

- 1) Select File → Reset startup defaults
- 2) Select RMS Measurements and dBV Axis Settings
- 3) Enabled Gen1 for 1 KHz and -10 dBV
- 4) Note the Peak L amplitude.
- 5) Engage the attenuator and again note the Peak L amplitude.

QuantAsylum QA401 User's Manual

- 6) Take the un-attenuated reading and subtract from that attenuated reading. This is the attenuator correction factor.
- 7) Close the QA401 application.

There is a file in the My Documents\QuantAsylum\QA401 directory called Default.Settings. Around line 53 of the file you will see the following:

```
50 <USBDelay>75</USBDelay>
51 <MarkersTrackPeaks>false</MarkersTrackPeaks>
52 <Weighting>None</Weighting>
53 <AttenVal>20</AttenVal>
54 <AuditionFileName />
```

The AttenVal is can be adjusted. Take the default value of 20 and add to that the attenuator correction factor you calculated above. For example, if your correction factor was 0.08, then you would replace the 20 with 20.08 as shown below. Close the file and restart the QA401 and verify the Peak value is the same

```
<USBDelay>75</USBDelay>
<MarkersTrackPeaks>false</MarkersTrackPeaks>
<Weighting>None</Weighting>
<AttenVal>20.08</AttenVal>
<AuditionFileName />
```

Note that there is a single correction value for the attenuator. You must decide if you'd like to split the difference between the left and right channel OR if you'd like to dial in one channel precisely. The channel to channel variation is generally quite small (<0.02 dB).

This value will need to be refreshed if you ever reset the startup defaults.

QA401 Basic Controls

The QA401 application is shown below. On the left side of the screen is the display area, and on the right side is the control panel.

QuantAsylum QA401 User's Manual



If your screen height becomes limited, you can click and drag anywhere in the control region that there isn't a control. This will let you scroll the control region to hide some controls and reveal new controls. This will work with both your mouse and with a finger if you have a touch screen.

In the display above, all on-screen annunciators are shown so that you can see where they would appear during normal operation. The description of each is below:

User Weighting File Name: This region will show a user-weighting file name if it has been loaded. A user weighting file can be useful for adjusting a measurement made by a mic that has a calibration file.

Input Clip L/R: This indicates that the input is exceeded the current range setting. Generally this isn't harmful. If you are in the +6 dBV range, then you can change the max input level to +26 dBV. If you are already in the +26 dBV range and this message appears, then you will probably need an attenuator. Note when connecting/disconnecting or changing ranges you might see a range of on-screen messages appear that will be transitory: They will show up during the change and then disappear once the changes have settled.

Output Clip L/R: This indicates you have selected an output level that is at the maximum capability of the hardware.

ExtGains: This indicator means there are output/input gains that have been set in the dBV Context Menu.

RANGE: Sometimes during an acquisition the state of the relay might change in response to a transient event. This indicator is a warning that the last acquisition is likely invalid because of an attenuator change that occurred during acquisition. For example, if you have the max input level set to +6 dBV, begin making a log acquisition and during that time the input goes to +12 dBV, then the overload protection will

QuantAsylum QA401 User's Manual

automatically engage the relay and release it once the offending level is removed. This would trigger the RANGE annunciator.

MUTE: In the GEN1/GEN2 context menu, you can mute left or right channels. This can be useful if you are making cross-talk measurements. If you have muted a channel, this annunciator will remind you of that.

Atten 20 dB: When the attenuator is engaged, this indicator will be present.

Mirror: You can “mirror” the Gen1 output to the DAC on your computer, which can be helpful if you are making DAC measurements. That is, if you set Gen1 to 1K and -1 dBFS, then the PC will emit a 1 kHz tone at -1 dBFS when the Gen1 is active. When mirroring is active, you will see this message.

FFT too small: When making Frequency Response measurements with a chirp, you need to have an FFT of a suitable size to ensure the chirp can fit into the time allotted. If you have selected an FFT that is too small, this message will appear. If you see this message, just bump up the FFT size until it turns off. Generally, you will see this message at 48K sample rates when FFT sizes are 2K or smaller.

Up/Down Adjustments

Some controls facilitate setting operating ranges. In these cases, you'll see an up/down control:

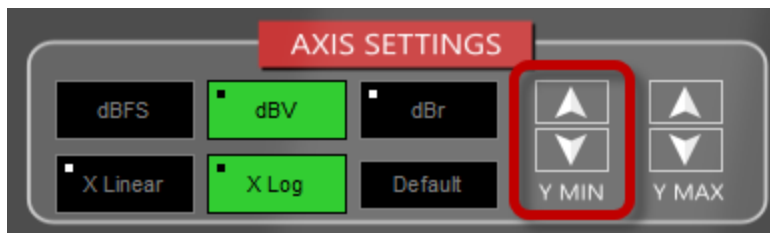

You can push the up/down buttons with mouse clicks or you can hover your mouse over either up/down button and use the mouse wheel to quickly adjust the control settings.

Context Menus

While perusing the QA401 menus, you'll likely notice they are very sparse compared to other signal analyzers. This is because the QA401 makes extensive use of context-sensitive menus. Functionality is grouped under the various buttons that enable that functionality.

In the example below, note the dBV button has a dot in the lower left corner. If we want to bring up a context menu related to the dBV settings, we can click on that button while holding the control key down. If a button doesn't have a dot (such as the dBFS button), then it means the button doesn't have a context menu.

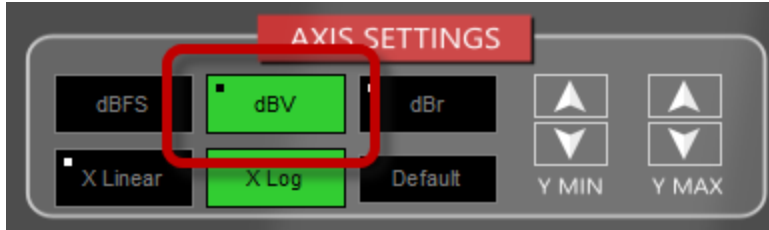

Control-click on the dBV button yields the following menu:

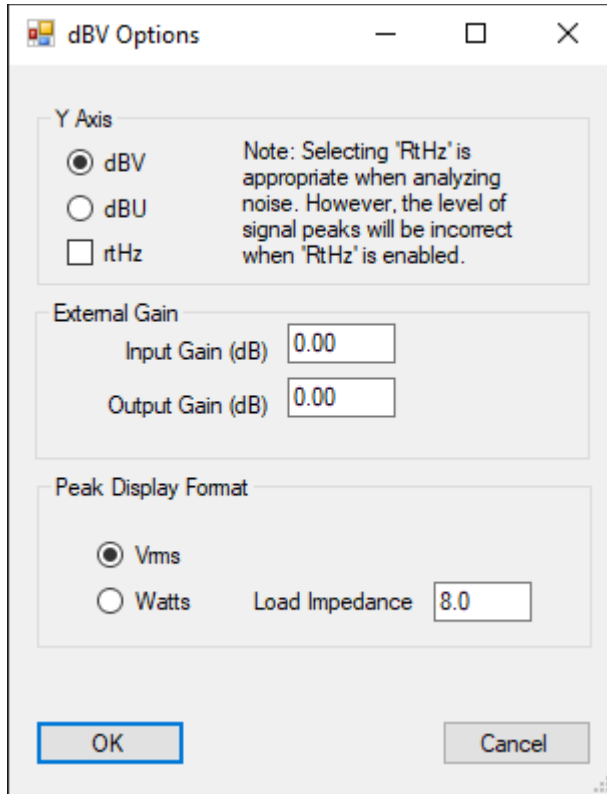

This is a very important concept related to the QA401 interface: **Settings related to a particular function are adjusted in a context menu, and that context menu is activated by control-clicking the button.**

Control Overview

There are a few basic control groupings on the analyzer, and these are covered below.

Run/Stop Button

The Run/Stop button is prominently located at the bottom of the control panel.

This button starts and stops the analyzer acquisition, although that can also be accomplished with the space key (see the section on [soft keys](#)). In the first picture below, you can see the analyzer expanded to full screen, and the red box highlights the Run/Stop button:

QuantAsylum QA401 User's Manual

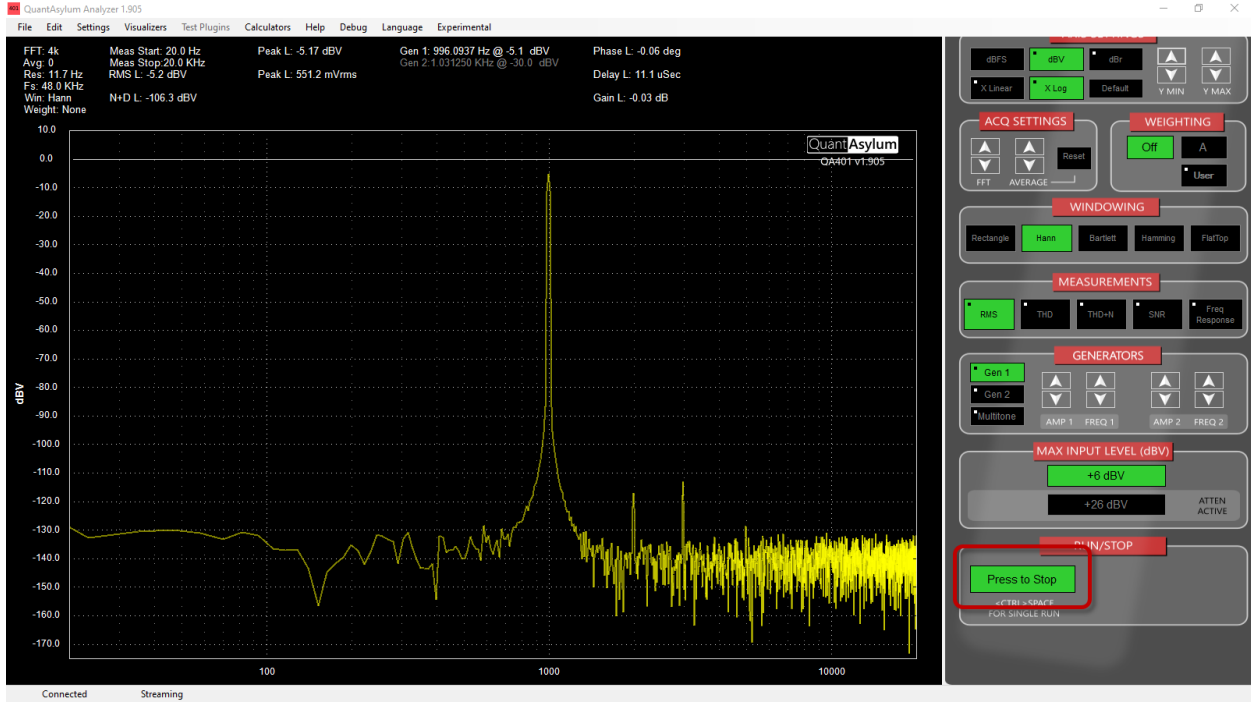

Above the Run/Stop button is the input level setting. When the +6 dBV button is pressed, that means the max input level is +6 dBV and any input in excess of that level will clip. When the +26 dBV button is pressed, that means the max input level is +26 dBV and input beyond that level will clip.

As is typical, the noise performance of the analyzer is substantially better in the +6 dBV mode of operation.

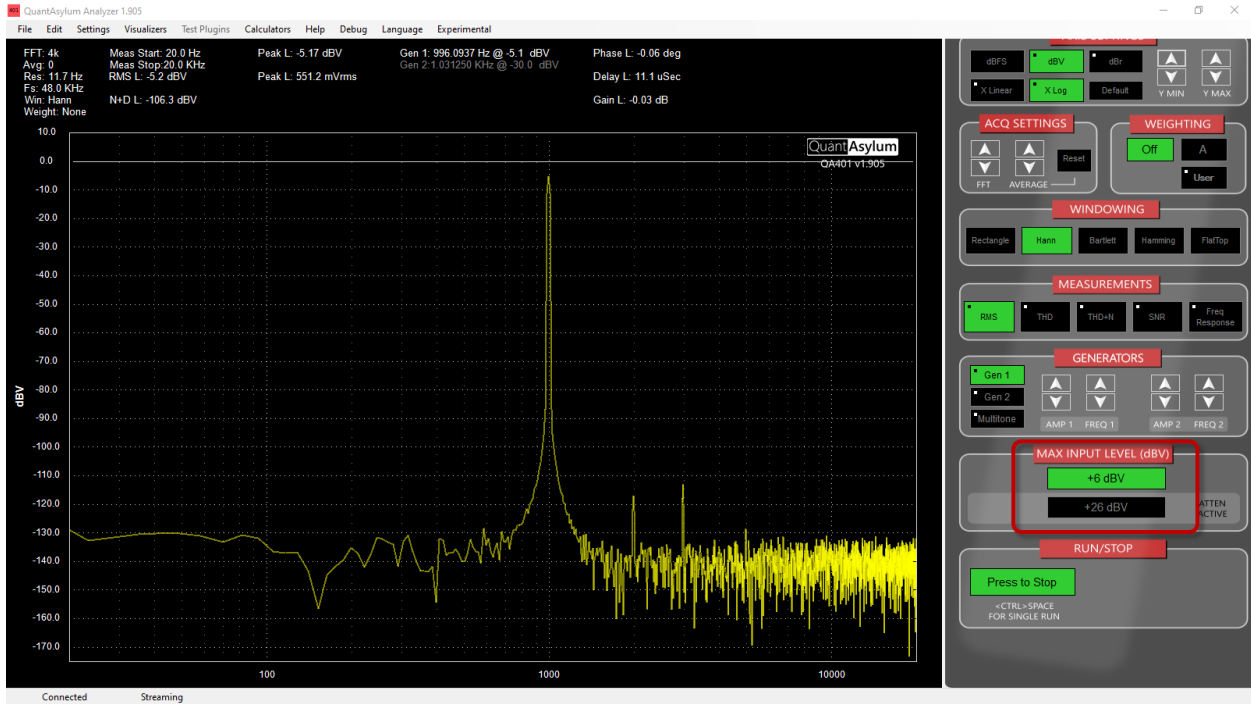

Display Options

The buttons below determine what is shown on this display.



The **time** button displays the transmitted and captured waveforms in the time domain, similar to what you would see on an oscilloscope. With the time and input button pressed, we can see what was captured by the analyzer. Sometimes you can forget that you are looking at the output data. The output data is exceptionally clean and might confuse you into thinking that you are looking at test data from the device under test. For this reason, when you have selected to look at the output data, you will be reminded with an on-screen indication that you are viewing output data.

Below, we can see the input data in the time domain. Using your mouse, you can select a region of the trace to zoom in. To zoom back out, press the "Default" button the axis settings section.

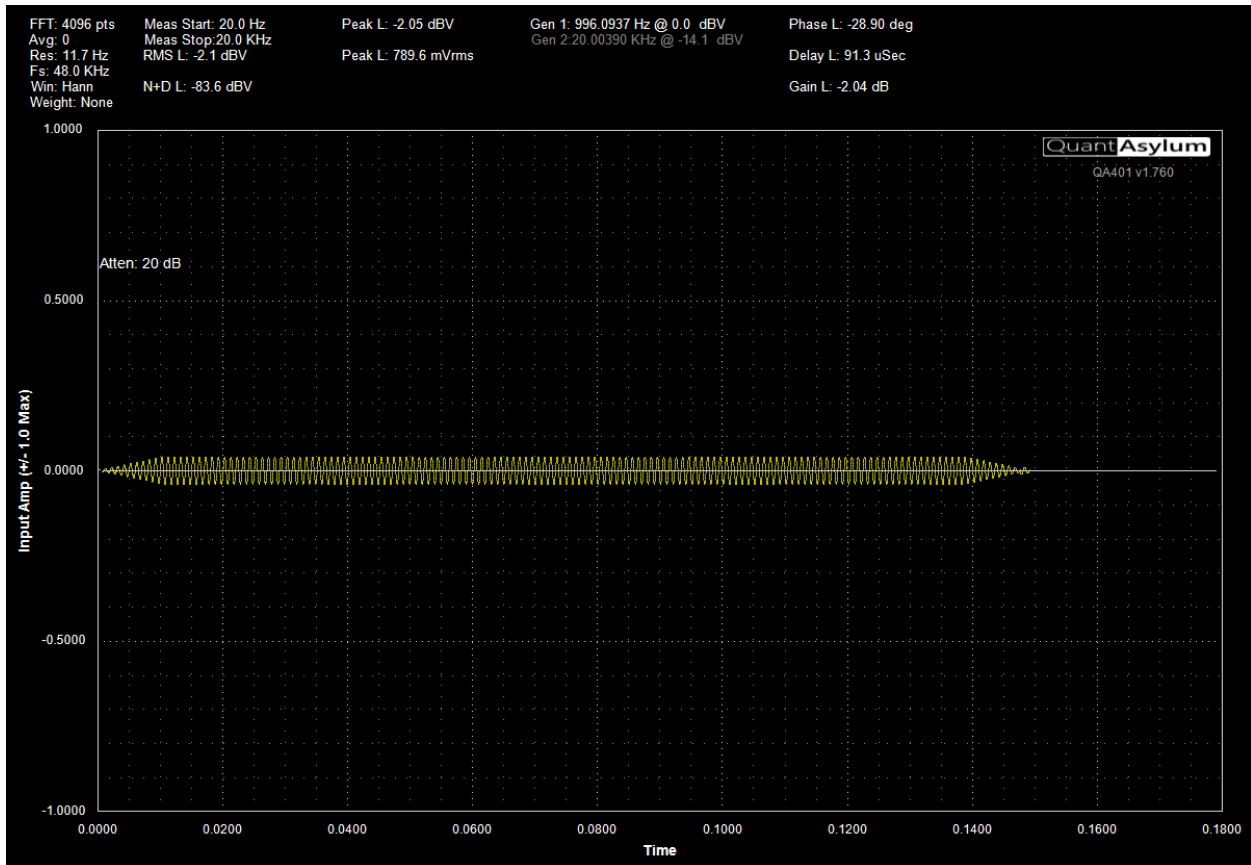

QuantAsylum QA401 User's Manual

Similarly, we could push the **output** button and see the signal that was generated by the analyzer. If we zoom in on the generated waveform (by dragging to the region we want to see using the left mouse button), then we see the output (and input) waveforms have 3 distinct regions.

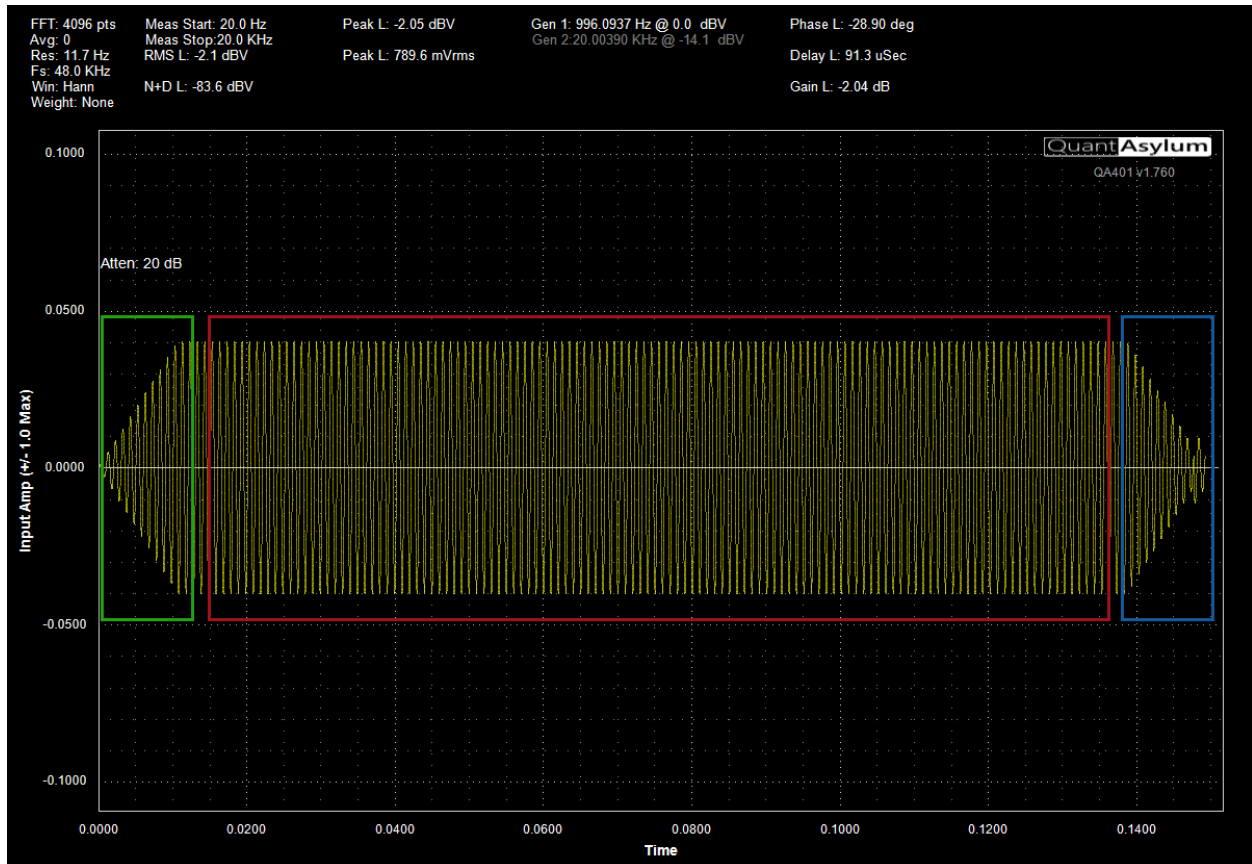

The green box shows the ramp up period of the output waveform, the red region shows the constant amplitude portion, and the blue region shows the ramp down region.

At this point, it's important to highlight that the QA401 does not operate with constant stimulus tones. The QA401 operates with stimulus bursts. The reason for this is to ensure that the full transaction with the hardware can be treated as a discrete event with a clearly defined start and stop point. Each transaction can start from a known state, and finish in a known state, and if various checkpoints along the way are not met, then the transaction can be counted as flawed and the results can be rejected.

The ramp up period of the waveform allows the various output audio stages external to the QA401 to stabilize their DC operating points. This gentle ramp also ensures audible pops are avoided that might harm power output stages.

The constant amplitude region is the region over which the FFT will be computed.

The ramp down region ensures again that a sine wave isn't terminated mid cycle which might also result in a click or pop, and it ensures the DC level is gently returned to zero.

QuantAsylum QA401 User's Manual

Normally, you'll be looking at the display with the following buttons pressed: Freq, Input and Left and/or right. This will show you the captured FFT data on the incoming signal.



When the right button is pressed, (it is un-pressed as shown above), the display will show the right channel data in the color red. Below, we see the left channel data shown in yellow, and the right channel data shown in red. And of course, if we only wanted to show right channel data we would simply turn the left display off by pressing the left button.

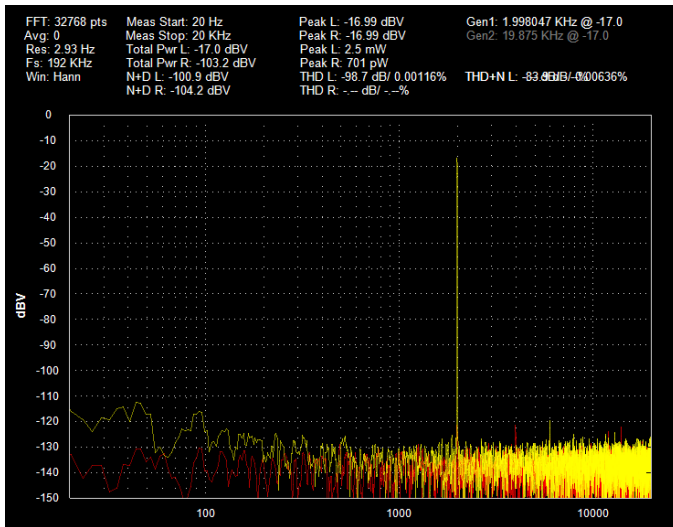

Axis

dBFS, dBV, and dBr Buttons

The axis controls select our units for the Y axis and allow us to adjust the X and Y axis settings. Below we see this control groups. The top 3 buttons set our Y Axis units. The dBFS button shows absolute units relative to the ADC and DAC maximum output levels. Generally, you'll want to be in dBV mode for most measurements.

The dBV button shows our levels in absolute RMS voltage levels relative to 1 Vrms.

QuantAsylum QA401 User's Manual

The dBr button allows us to display arbitrary levels relative to whatever we pick as a reference.

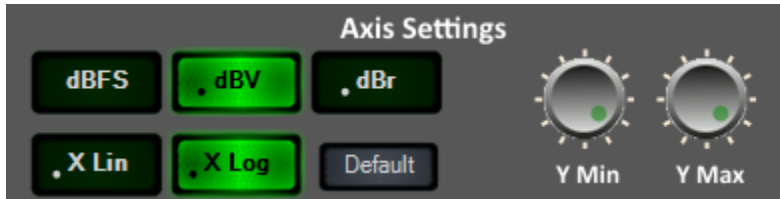

Since the dBFS levels are absolute, there is no adjustments to be made via context menu.

dBV Context Menu

The dBV levels are also absolute, but in dBV mode we can specify whether external gains are attached to the inputs and outputs, and we can also opt to render the peaks in watts if we specify the impedance connected.

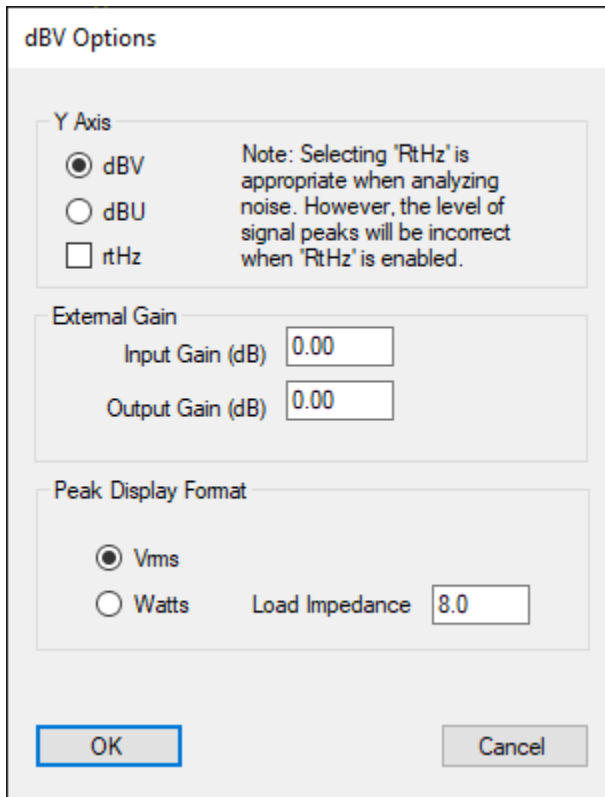

Note that input gains will adjust all displayed data by the specified gain amount. In other words, if you specify that you have a 0 dB external gain, then 1Vrms signal will be reported as 0 dBV. But if you specify that you have a 10 dB external gain, then that same 1Vrms signal will be reported at -10 dBV.

For both input and output external gains, the correct way to think about the settings is that if you have non-zero gains specified, then the values displayed on the screen will reference the levels on the “other side” of the gain block, as shown below.

QuantAsylum QA401 User's Manual

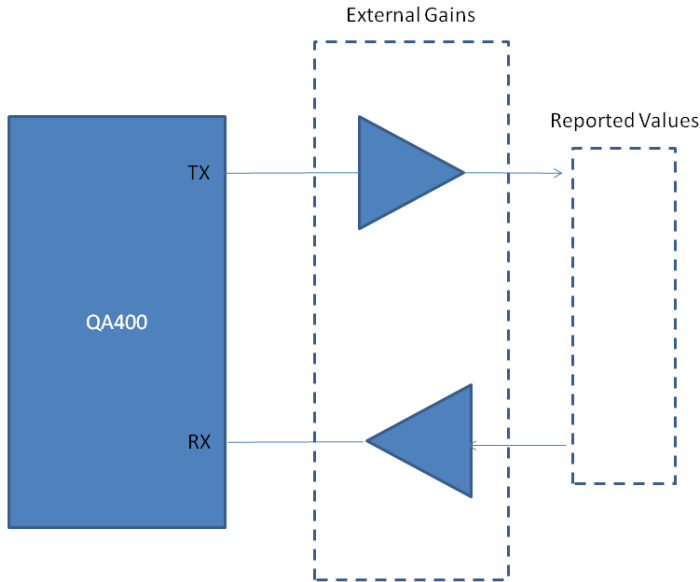

The absolute peak levels are reported on the screen regardless of the Y Axis settings. In the case below, you can see the peak levels are also reported in watts because we specified an 8 ohm impedance. This is useful for seeing the displayed power from a power amplifier.

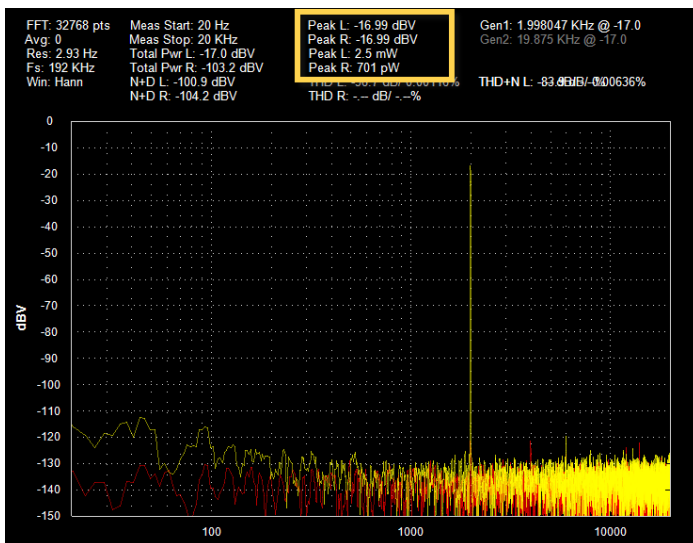

The 'rtHz' checkbox is appropriate if you are looking at noise levels. When checked, you'll notice that noise levels remain constant regardless of FFT size. But peak values will change depending on FFT size. When unchecked, larger FFT's will show a reduction in noise while maintaining constant peak amplitudes.

dBr Button and Context Menu

QuantAsylum QA401 User's Manual

When using the dBr menu, it's important to understand that the attenuator adjustments are not automatically made for you as they are in the dBV axis setting. For example, in the dBV setting, if a signal is reported as 0 dBV with the attenuator on, then it will also be reported as 0 dBV with the attenuator off. But in the dBr menu, that adjustment isn't made for you—you are responsible for the calculation in your gain budget. We'll go through an example of that in more detail below.

The dBr context menu is shown below. The dBr settings is useful when you want to measure relative to something else. For example, a measurement microphone might output -38 dBV at 94 dBSPL. If you wanted the graph to show levels in dBSPL, then you would use the dBr context menu to specify that mapping.

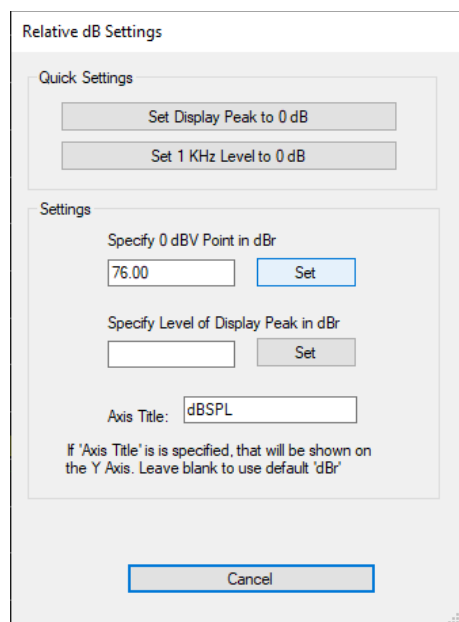

There are 4 ways to specify the absolute level from this menu.

The first two buttons are shortcuts for common actions. The first button allows you to make the current display peak the new 0 dBr level. This is useful if you are in dBV mode and wish to easily see a change relative to the current peak. For example, you might measure the signal from an amp at -37.25 dBV. If you click on the dBr context menu and press the “set Display peak to 0 dB” button, and then press the dBr button, the display will update to show the peak at 0 dBr. Now you can make a change to your circuit and repeat the measurement and see the new gain relative to the old gain.

The second shortcut allows you to specify the current value at 1 kHz to be the new 0 dB point. This is useful if you are looking at the spectrum and want to easily find the 3 dB points. Instead of measuring at 1 kHz and then looking for a drop of 3 dB, you can instead specify 1 kHz to be the 0 dB point, and then quickly scan the plot to find where the response crosses at -3 dB.

The Settings group box provides 2 methods for specifying the reference point.

QuantAsylum QA401 User's Manual

The first box can be used if you'd like to convert a dBV reading to another set of log units. This is helpful if you have a reference mic or other transducer with a calibrated output. For example, let's say you have a mic that emits -38 dBV for a 94 dB SPL signal. Next, let's say that mic went through a 20 dB pre-amp before going into the QA401 and that the QA401 attenuator is off. That means that for a 94 dB SPL signal into the mic, the signal into the QA401 would be -18 dBV (-38 dBV + 20 dB preamp gain). We'd like that show 94 dB SPL on the Y axis in the dBr mode. So, here we'd specify $0 \text{ dBV} = 94 + 18 = 112$ as the conversion factor.

With the conversion factor set, we can adjust the signal into the mic to get precisely -18 dBV. And then press the dBr button and read 94 dB SPL from the peak. Note, too, that by specifying the Axis Title, we can show the units we'd like on the Y axis. This makes it very easy to read absolute values correctly from precision transducers.

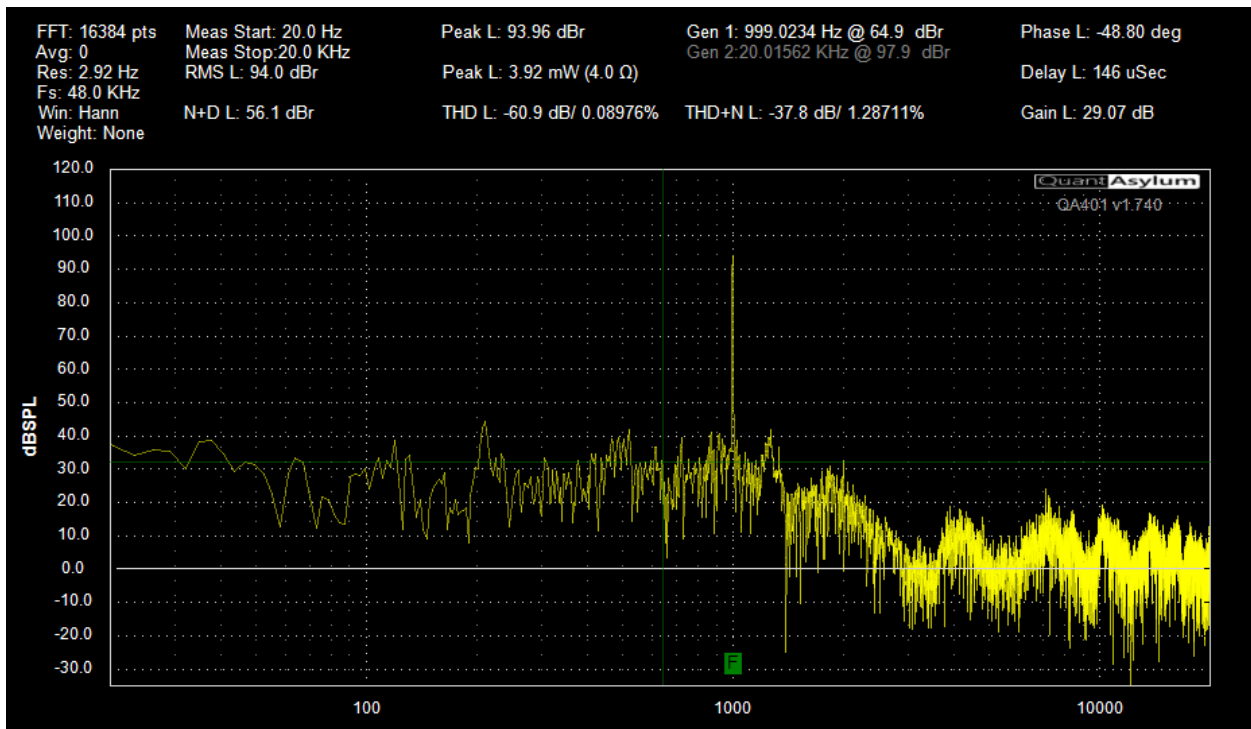

Remembering that the dBr axis setting doesn't take the attenuator state into account, we can repeat the math above with the attenuator engaged. This time, instead of 112 dB conversion factor, we'd need an extra 20 dB added to consider the attenuator. And so, with the attenuator on we'd want to specify 132 as the conversion factor.

In summary, if you have a mic with a specified sensitivity in the form of X dBV at Y dB SPL, then the conversion factor you'd enter with the attenuator off is $-X + Y - G_{\text{preamp}}$. With the attenuator on, the correction factor would be $-X + Y + 20 - G_{\text{preamp}}$. That is, for a mic with -38 dBV at 94 SPL and a 20 dB preamp, with the attenuator off the correction factor is $-(-38) + 94 - 20 = 112$. With the attenuator on, this becomes $-(-38) + 94 + 20 - 20 = 132$.

QuantAsylum QA401 User's Manual

It is very important to run a sanity check verifying the basic levels are as expected. There are a lot of places where various offsets can be set inside the QA401 software that can change readings. For example, if you have specified any External Gains in the dBV menu then the equations above will need to be adjusted.

Finally, the last "Set" button in the Settings section allows you to specify that the current on-screen peak will become the new reference point, and you can specify the level that peak will be. Let's say, for example, that you have an input attenuator of roughly 10:1 in place, and you are measuring the output of an amplifier. You adjust the amplifier output so that you measured 5Vrms with your DVM (about +14 dBV). You are then left with a level of roughly -6 dBV coming into the analyzer. If you specify that the peak level is 14 dB, then the display will indicate the same as the absolute value you measured with your DVM.

X Lin/X Log Buttons and Context Menus

The X Lin button specifies that we want to view the X Axis with a linear scale, while the X Log buttons indicates we want to view the X Axis with a log scale.

The screen captures immediately above have shown the log setting, while this shot below shows the linear setting.

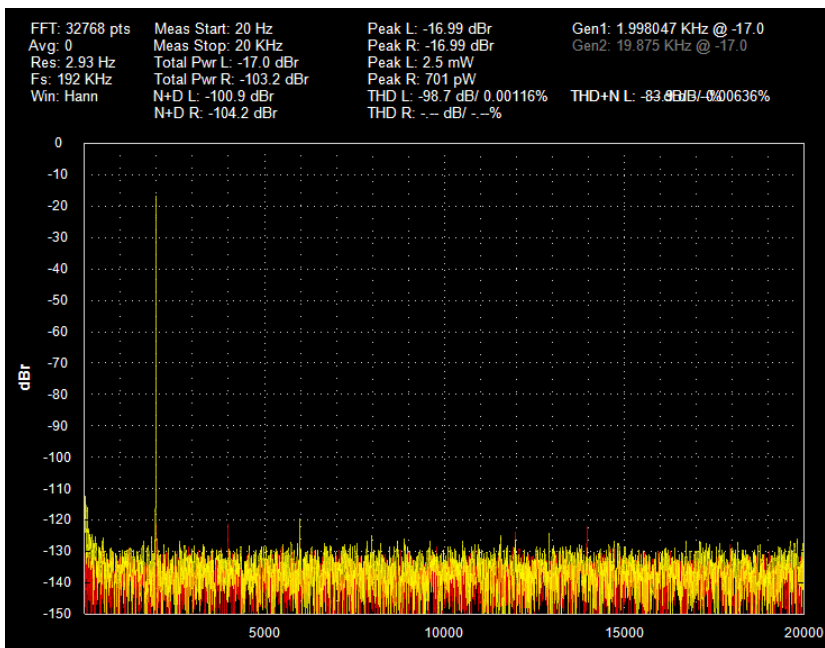

The context menus for both the log and linear settings button allow you to set start and end display frequency. The linear button also allows a center frequency and span to be set

QuantAsylum QA401 User's Manual

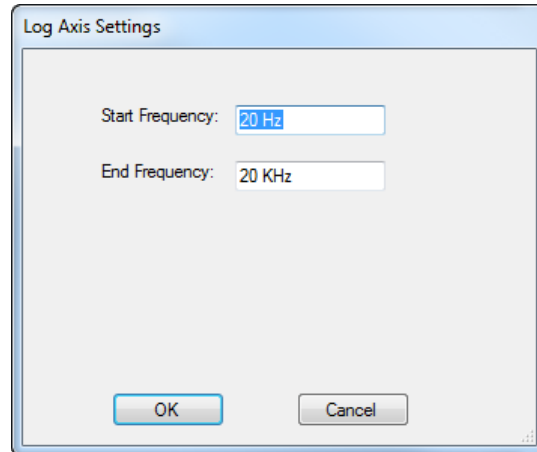
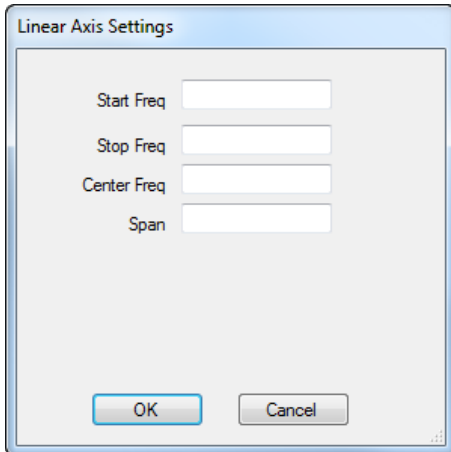

Recalling again the Axis controls, the purpose of the default button is to permit you to zoom to your default settings after scrolling or panning the display area. The Y Min and Y Max knobs allows adjustment of the Y Axis settings.

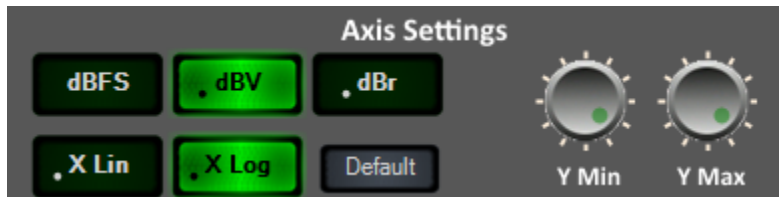

Display Panning and Scrolling

You can zoom to details in the display area using the left mouse button. Click the upper left region you'd like to highlight, and drag to the lower right region. You'll see a box drawn to show you area that will be zoomed. Upon releasing the drag, the new area will be zoomed.

You can pan around the display area by dragging with your middle mouse button. Below, you see a detailed zoom of the display. Press the Default button in the Axis controls to revert to the normal display settings when you are done zooming.

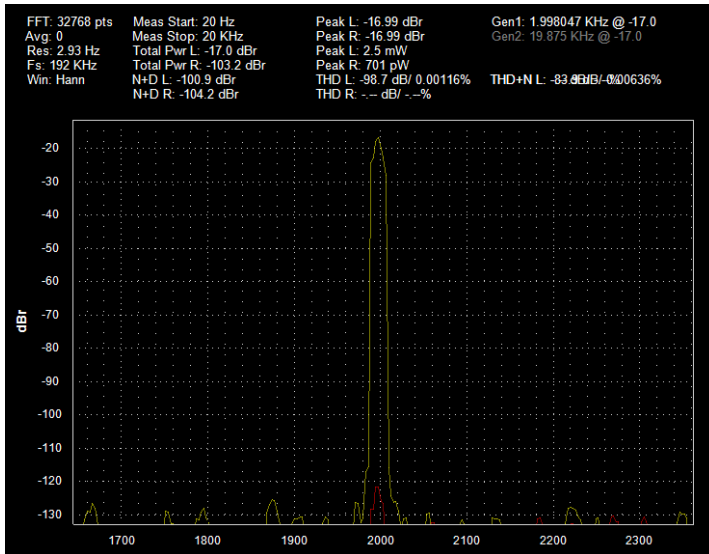

Titles and Markers

Titles can be added to the graph by right clicking in the display area. This will bring up a context menu and the first menu option will permit you to add or edit a title.

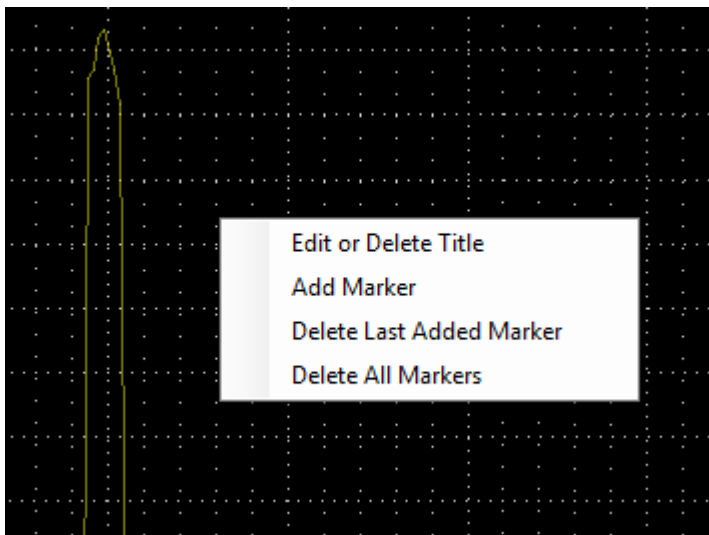

The title will appear above the graph region, and below the measurement data.

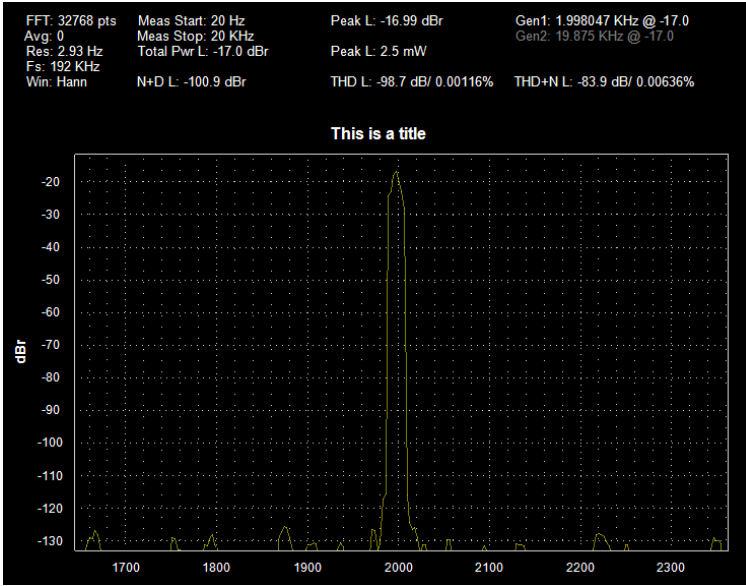

Adding Markers

Markers are useful for measuring amplitude differences in signals you see. In order for markers to be shown, you must have a single channel (left or right) active, but not both.

The simplest way to add a marker is to hover over the peak of interest and then press the 'm' key or you can click the peak with the mouse. Alternately, you can hover over the peak and the right click and select the Add Marker menu item. When adding markers, think of the distance to nearest trace feature rather than your Y location. When you add a marker, the software will look for the nearest trace feature and NOT the current Y value. This means if you are to the right of a tall peak and add a marker, the marker will be added to the tall peak and NOT the current Y position.

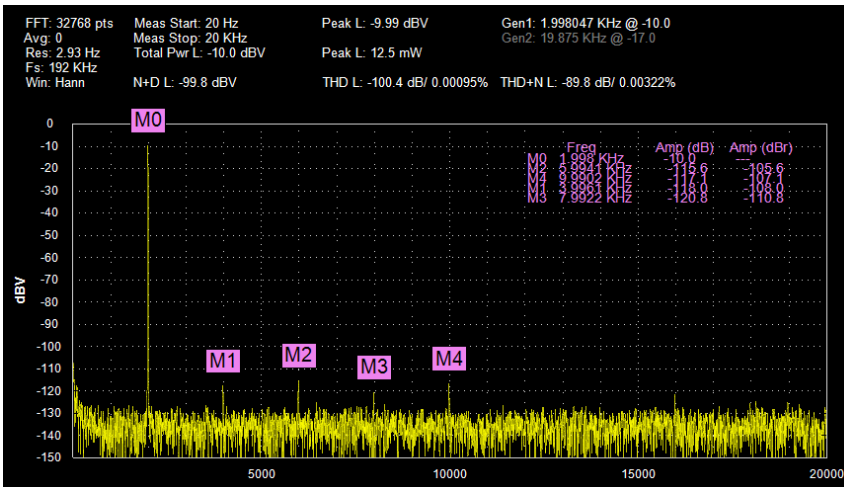

QuantAsylum QA401 User's Manual

If you add a marker in an unexpected place, you need to delete all the markers and start over again.

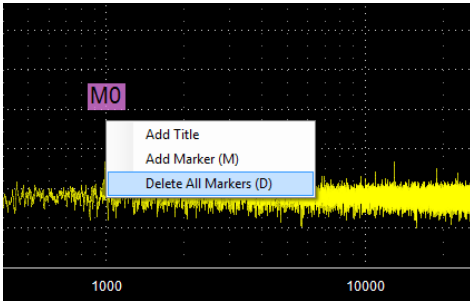

Markers details will show up in the display area. This allows us to see the frequency of each marker, the absolute amplitude of each marker and the relative amplitude of each marker. Note that markers are always sorted according to amplitude. The strongest signal will always be listed first (regardless of marker name), then the next strongest, etc. This makes it very easy to quickly see the amplitude of each signal relative to the strongest signal.

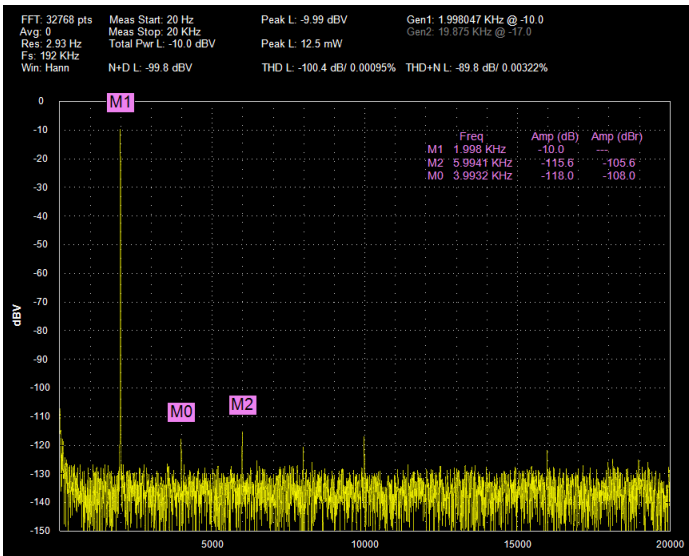

Acquisition Control

The acquisition settings determine the resolution of your capture, and also how much filtering is performed.



The resolution knob can be adjusted to show the level of detail you require. More detail takes more time to capture. The averaging knob determines how many samples are averaged when the display values are computed. Note that averaging doesn't change the noise floor, but it does make it easier to see signals that might be buried in noise. Since long averaging can delay the time it takes to see changes, there is a reset button. This is helpful if, for example, you change the input frequency. In this case, you can push the Reset button and immediately see the new average get built. Without this, you'd have to wait to see the old signal average decay away.

As you adjust the resolution and averaging, the parameters below are updated in the display.

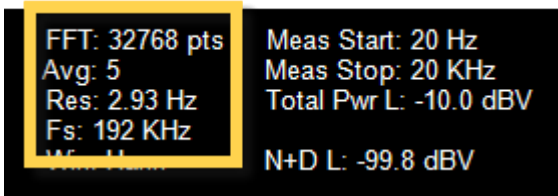

Weighting

Weighting can be applied to measurements if needed. While there are a lot of different weighting functions defined, most are seldom used. The most commonly specified weighting function is A Weighting, which attempts to adjust for the loudness as perceived by the human ear. Because the ear is less sensitive at lower and higher frequencies, the weighting works to attenuate the values below roughly 1 KHz and above 4 to 5 KHz or so.



On the QA401, weighting can be applied or removed by pressing the A weighting button, or the Off button. When the Off button is selected, then no weighting is applied to the displayed data. When the A button is selected, then the A weighting is applied. Notice that at 1 KHz, the A weighting has a gain of 0 dB, thus a 1 KHz signal will have the same amplitude whether or not weighting is applied.

Wikipedia lists the response curves for the various weighting function as follows:

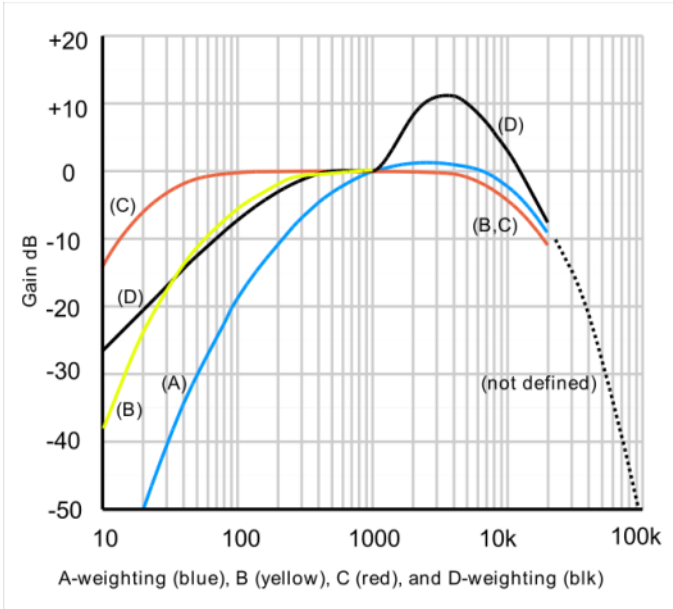

User Weighting

You can specify arbitrary weighting functions. These can be helpful if you want to flatten an RIAA equalizer curve, for example. A phono amp generally shows a very high-gain and lower frequencies, and a much lower gain at high frequencies. It can be difficult to tell if the response is correct. But by applying the “RIAA Playback Response” curve, you can flatten the overall response and look at deviations from a flat line.

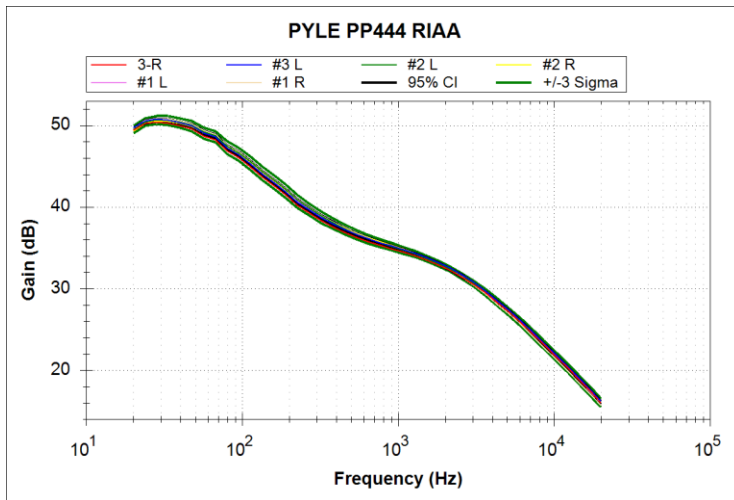

The weighting files are in the UserWeighting directory. If you open a file in a text editor, you will see a description of the file format.

You can also import microphone calibration files. They might need to be modified a bit to be accepted. But generally, the importer will accept a ‘*’ or ‘#’ symbol at the start of a line as a comment, and there

QuantAsylum QA401 User's Manual

must be at least two pieces of data on each line, separated by a comma or a tab. Decimals must be indicated with a period.

The first piece of data is the frequency, and it must be greater than the previous frequency entry. The data is specified in dB. The data should reflect the measured response. That is, if you import a mic calibration file, and the calibration data indicates +7.4 dB at 20 kHz, this means that the measured result at 20 kHz needs to have 7.4 dB subtracted from the measured value.

You can verify this by going into FR mode with expo chirp selected and putting the QA401 into loopback at, say, -30 dBV output level. With weighting off, you will see a flat line at -30 dBV. With user weighting selected and your mic calibration file imported, you should see -30 dBV at 1 kHz (since the mic files are generally normalized to 1 kHz). And if the mic calibration file shows +7.4 dB at 20 kHz, then with User weighting enabled, you should see -37.4 dBV at 20 kHz.

Windowing Functions

The FFT process assumes the captured data repeats infinitely. If the data sent to the FFT function contains, for example, 10.5 cycles of a waveform, then the extra half cycle will cause errors in the resulting spectrum. To get around this, a windowing function is applied to the data. This function will gently taper the amplitude of the collected data (prior to FFT) down towards 0 near the start and finish of the sample buffer. By doing this, the extra half cycle that appears to immediately truncate will be suppressed. The downside to this is that some other distortions will be introduced into the displayed spectrum. But the introduced distortions are much less objectionable than the distortions that arise from an abruptly terminated waveform.

Using the input display feature on the QA401, we can look at this in more detail. Using a small buffer (512 samples) and low frequency waveforms, we can see what truncations can do to our data. For these tests, we set the windowing function to Rect (which means no windowing is applied).

First, let's look at a 10 Hz waveform at 16K points, 48Ksps. We can see the input waveform below

QuantAsylum QA401 User's Manual

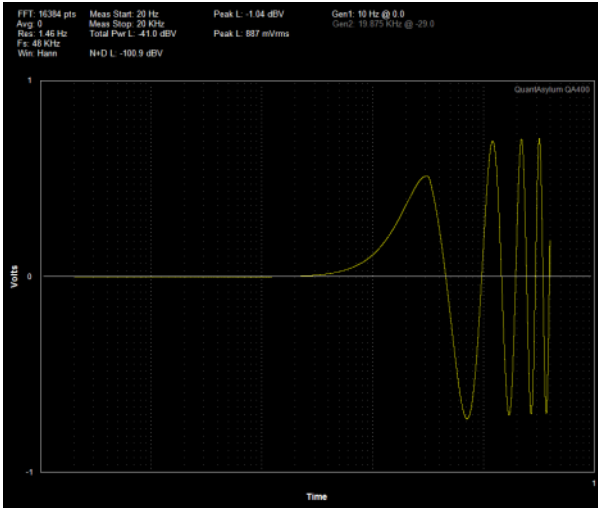

Notice the right side of the waveform above is chopped off. With windowing turned off (Rect), we see the resulting spectrum below. Notice how much energy there is across the entire band, even after 10 KHz. This is due to the truncated waveform.

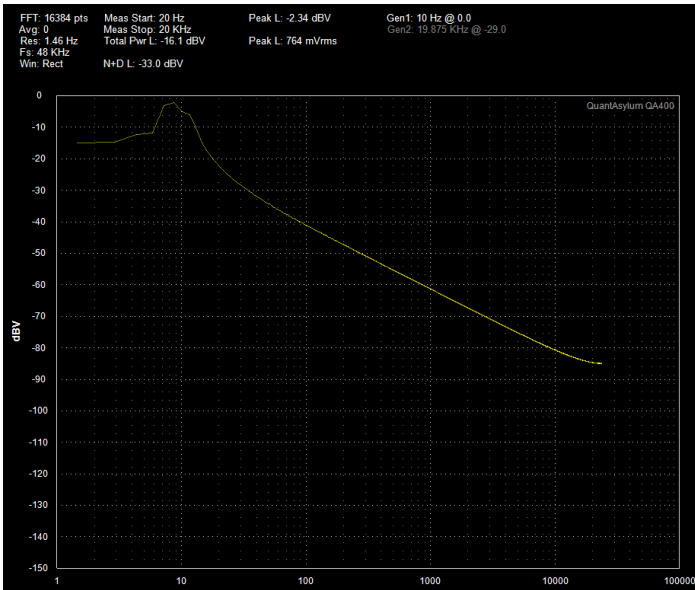

But if we switch the windowing to Hann, the energy at higher frequencies is suppressed

QuantAsylum QA401 User's Manual

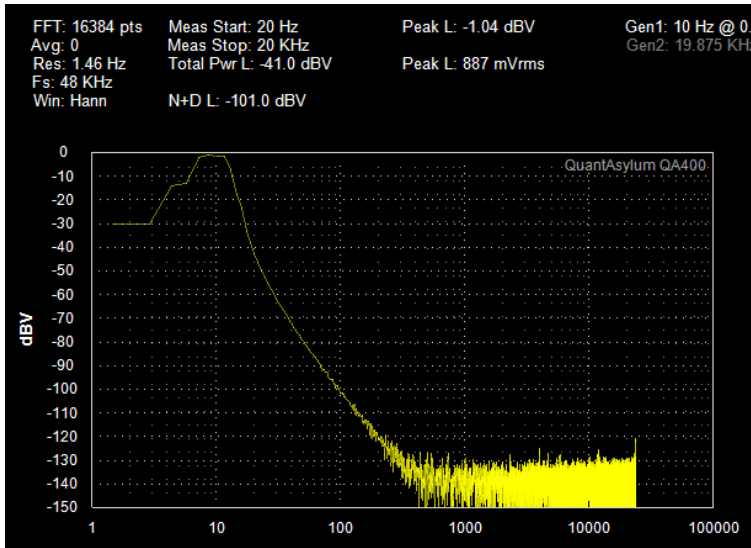

But what if we pick Flat Top windowing? What do we see then? The response looks worse again. What is happening?

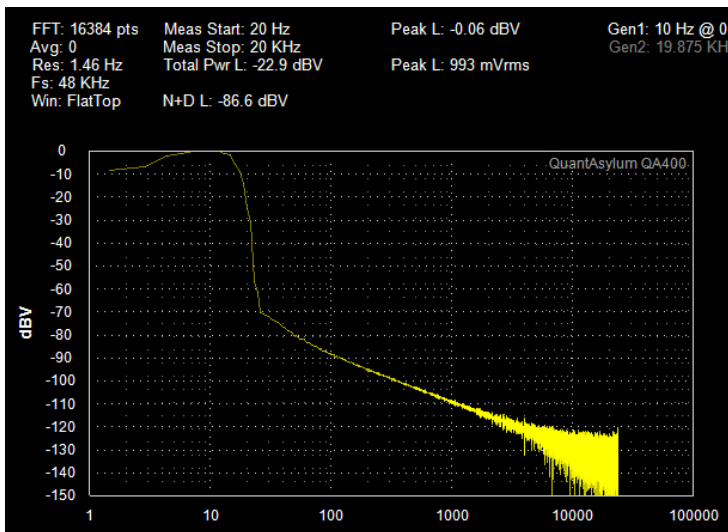

It turns out that windowing functions are very complex, and you should set them based on what you are trying to measure. Any window option you pick will be a balance between resolution, leakage/dynamic range and ripple.

QuantAsylum QA401 User's Manual

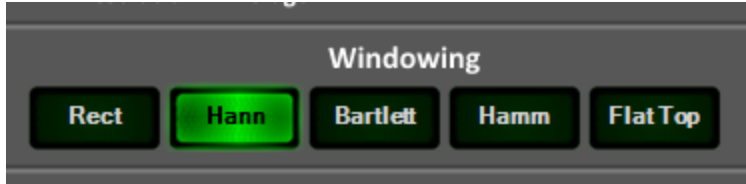

The QA401 supports 5 basic windowing functions as shown above:

Rect	This is also commonly called Rectangular, boxcar, uniform, or no windowing. This is most useful when you can precisely ensure you have collected an integer number of cycles of the waveform. When you can do this, you can then apply no windowing and introduce the minimum amount of distortion to your displayed data. This is the reason you see ADC data sheets measuring odd frequencies at odd sample rates. They are striving to capture an integer number of cycles so that they can apply no windowing. Under these conditions, the Rect can deliver excellent results for ripple, dynamic range and resolution.
Hann	The Hanning window provides a great balance between ripple, dynamic range and resolution for all sorts of signals. It does have about 0.6dB of ripple. If amplitude accuracy is important, then consider Flat Top.
Bartlett	The Bartlett window is similar to Hann, with worse leakage and frequency resolution. Generally, unless a procedure calls specifically for this window, you'll want to use Hanning.
Hamm	The Hamming window is similar to Hann, but with a bit more spectral leakage. Generally, unless a test procedure calls for this windows specifically, you'll want to use Hanning.
Flat Top	For accurate amplitude measurements, the Flat Top is the best choice. On the QA401, you'll generally see less than 0.05 dB of amplitude variation using this selection.

Measurement Types

Definitions

The QA401 makes basic audio measurements quickly, can perform more advanced sweep-type measurements and can permit 3rd party applications to control the QA401 for even more sophisticated measurements.

Basic audio measurements usually involve terms such as SNR, THD and SINAD. But often it can be confusing to remember what each measurement refers to precisely. The purpose of this section is to clarify the meanings as incorporated in the QA401. The Analog Devices app note MT003¹ is an excellent write-up on the topic.

Total Power is defined as the RMS of the spectrum bounded by the user-set Measurement Start and Measurement Stop parameters.

¹Kester, Walt, *Understand SINAD, ENOB, SNR, THD, THD + N, and SFDR so You Don't Get Lost in the Noise Floor*, Analog Devices MT-003

QuantAsylum QA401 User's Manual

N+D (Noise + Distortion) is defined as the Power Measurement minus the power contained in the fundamental. The fundamental is defined by the user, and can be either the frequency setting in the Signal Generator 1, or it can be the highest peak, or it can be a user specified frequency. If the input is disconnected, then a fundamental won't be present and the N+D will match the Power reading.

THD (Total Harmonic Distortion) is the ratio of the RMS signal power in the fundamental to the RMS sum of the harmonics. The harmonic is selected to be 2x, 3x, 4x...n of the fundamental, up to the Measurement Stop setting. So, if you have a 1 KHz fundamental, and a 20 KHz Measurement Stop setting, then the QA401 will measure up to and including the 20th harmonic. Similarly, if you have a 10 KHz fundamental and a 20 KHz Measurement Stop setting, then the THD will only reflect the 2nd harmonic.

THD+N (Total Harmonic Distortion + Noise) is the ratio of the RMS signal power to the Noise + Distortion as defined above.

A more concise way to look at this is to consider the following definitions:

N_{nyq} = This is the root-sum-square of all components, from the Nyquist Frequency down to (but not including) DC

N = Noise. This is the non-signal and non-harmonic signals contained in the specified spectrum. More specifically, this is the root-sum-square of the non-signal and non-harmonic signals.

D = Distortion. This is the sum of all harmonic peak values, not including the fundamental, up to the Measurement Stop setting. Note that the QA100 will only consider up to 100 harmonics.

S = Signal. This is the peak level of the signal.

SNR = $20\log(S/N_{nyq})$. This is the log ratio of the signal to noise. What is important here is that the noise does NOT include the harmonics. Note that on the QA401, the SNR reading does not automatically include all of the noise up until Nyquist. The SNR reading on the QA401 respects the setting of the Measurement Stop frequency. To get a true SNR reading, you must ensure that Measurement Stop is set to the Nyquist frequency.

$$\text{SINAD} = 20\log(S/(N_{nyq}+D))$$

$$\text{THD} = 20\log(S/D)$$

$$\text{THD+N} = 20\log(S/(N+D))$$

QA401 Measurement Types

There are 4 basic measurements that can be done by the QA401. The measurements require the button to be pressed for the measurement result to be displayed. This is done for two reasons. First, each measurement takes time to perform. And second, showing a measurement on a presentation slide that isn't germane to the topic at hand can cause confusion. So, for this reason, you should only the measurements you wish to display, especially if you are going to share the data with others.



RMS/Power

The RMS (formerly Pwr) button refers to the power measurements. When this button is selected, the power will be computed across the specified measurement start and stop span. In the plot below, we can see a few key pieces of data related to this measurement. First, we can clearly see the measurement is performed over the 20 to 20 KHz interval. Next, we can see the total power measured in this interval is – 60 dBV. Since the noise is so far down below the signal, this makes sense. Next, we can see that noise and distortion (N+D) is -99.5 dBV. The N+D measurement is the measured power in the specified 20 to 20 KHz interval, but it DOES NOT include the power contained at the generator frequency. If the generator is turned off, you'll see the Total Power matches the Noise and Distortion power.

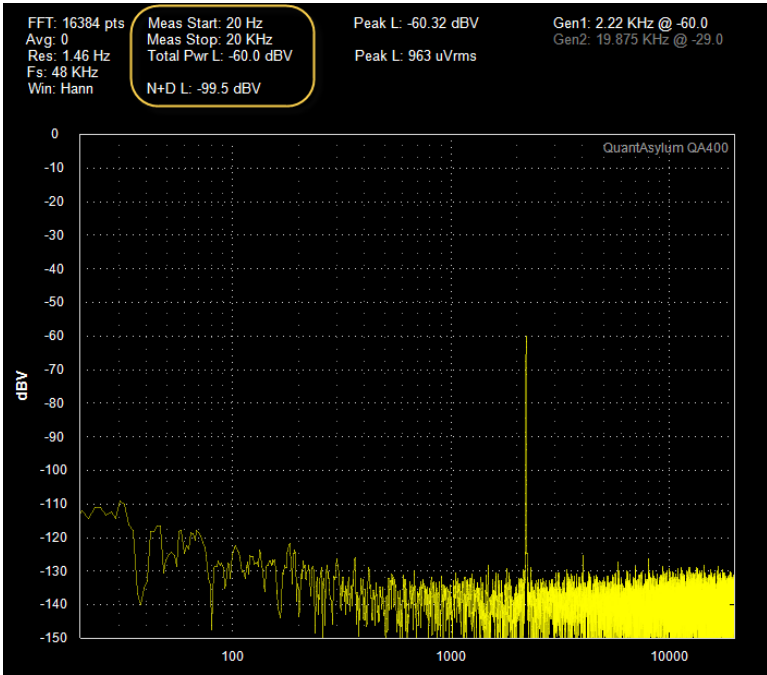

A common measurement is to measure the noise floor of an output circuit. If the output circuit has a voltage in the range of +/-5V, then the measurement can be made directly on the QA401 by applying the voltage to the BNC input terminals without regard for attenuator setting. Most line-level opamp amplifiers

QuantAsylum QA401 User's Manual

and battery powered headphone amps fall into this category. Even high-power class D amplifiers will do a very good job of ensuring high-voltage transients are not present on the outputs.

Another common measurement that might be made is measuring the output noise of a power supply. This requires careful consideration, because if the voltage exceeds 6 or 7V and the attenuator is disengaged, then very high transient currents can flow inside the QA401 and potentially damage the device performance.

The correct way to think about this is by the peak currents involved. If the attenuator is engaged, then there is no concern about the peak currents and the +50V/-7.5V cap rating applies. If the attenuator is NOT engaged, then a momentary current will flow through the input capacitor, through the 100 ohm current limiting resistor through a protection diode clamp, and then it will be clamped to the +/- 6.5V supply rails, limited by the 100 ohm resistor.

The max clamp current should be limited to 10 mA. If an external DC voltage of +/-7.5V is applied, this is roughly a 10 mA transient current. In other words, measuring a power supply's noise with an output greater than 7.5V requires special consideration.

The easiest way to solve this is to use the built-in attenuator. Even at +50V DC (the limit of the input capacitor), the attenuator will limit peak transient currents. However, if you are concerned about forgetting to engage the attenuator OR you need a noise floor that is better than the noise floor offered with the attenuator engaged, then an external current limit resistor can solve the problem.

As an example, to measure a 15V power supply, we want to use a $(15-6.5) / 0.01 = 850$ ohm resistor in series with the input. Rounding up to 1K is fine, because the thermal noise from a 1K resistor in a 20K bandwidth will be about 0.6 uVrms, and a really good power supply output noise value in the same bandwidth will be 15 uVrms.

FOR MEASURING THE NOISE OR SPECTRUM OF EXTERNAL HIGHER VOLTAGE OUTPUTS (GREATER THAN 5V IN MAGNITUDE OF DC BIAS), MAKE SURE A CURRENT LIMITING RESISTOR IS USED IN IN SERIES WITH THE INPUT TO LIMIT THE MOMENTARY CURRENTS TO NO MORE THAN 10 mA. MISTAKES HERE ARE NOT COVERED UNDER WARRANTY.

THD

The THD measurement is enabled by pressing the THD button.

The THD measurement will measure the ratio of all the harmonics of the fundamental (up to 100 harmonics maximum). Note that there are 3 ways to specify the fundamental frequency. You can use the settings on the first signal generator, or the highest detected peak, or a specific frequency. These are covered in the context settings below.

QuantAsylum QA401 User's Manual

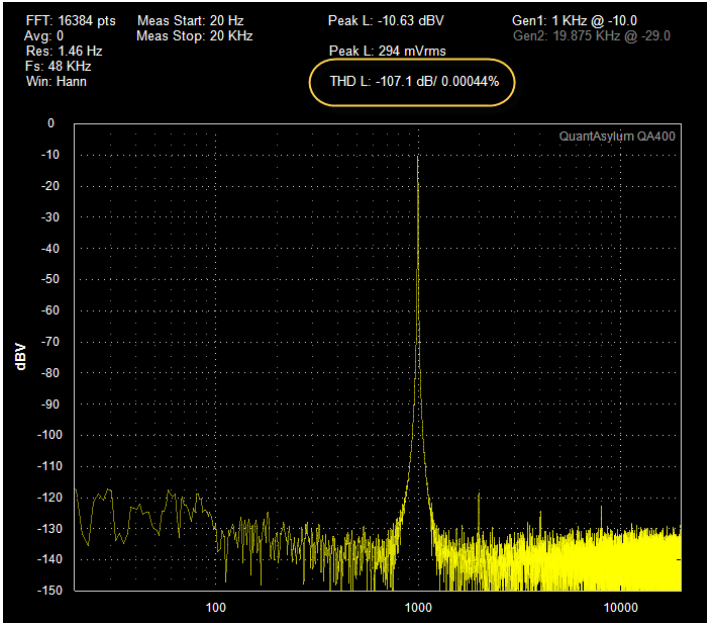

In the plot above, we can see the second harmonic is about -107 dB below the fundamental. If we use markers, we can see this a bit easier below. The THD function will sum the harmonic powers all the way up to the specified Measurement Stop. In the plot above, the sum of the harmonic power is -107.1 dB. To go from a dB measurement to a percent measurement, use the following:

$$\text{THD pct} = 10^{(\text{THDdb}/20)} * 100$$

This is done automatically in computing the % distortion figure.

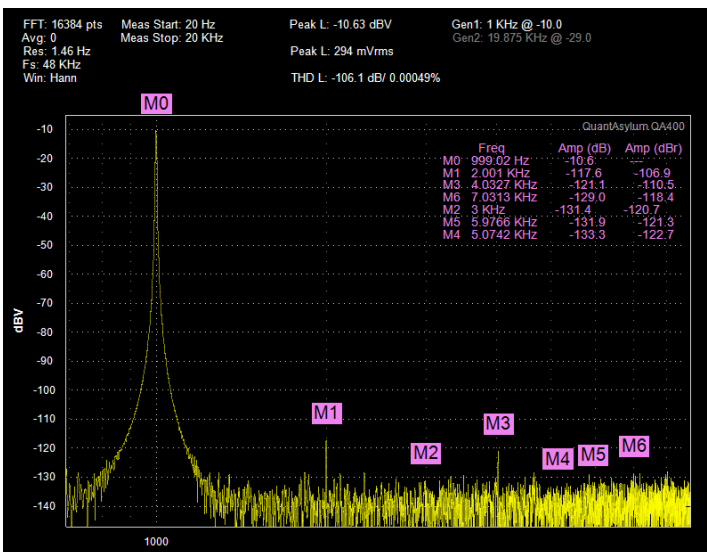

QuantAsylum QA401 User's Manual

One thing to keep in mind is that the Measurement Stop value sets the upper harmonic to be considered. If you are looking at a 1 KHz signal, then a 20 KHz stop value means you will look at all harmonics up to the 20th harmonic in your THD calculation.

But what if you have specified an 11 KHz signal? In that case, the second harmonic will be at 22 KHz, which is beyond the 20 KHz Measurement Stop limit. In that case, the second harmonic will never be seen, and the THD value won't make much sense. In the example below, we can see a marker at 11 KHz and 22 KHz, and since the Measurement Stop is set to 20 KHz the second harmonic is never seen.

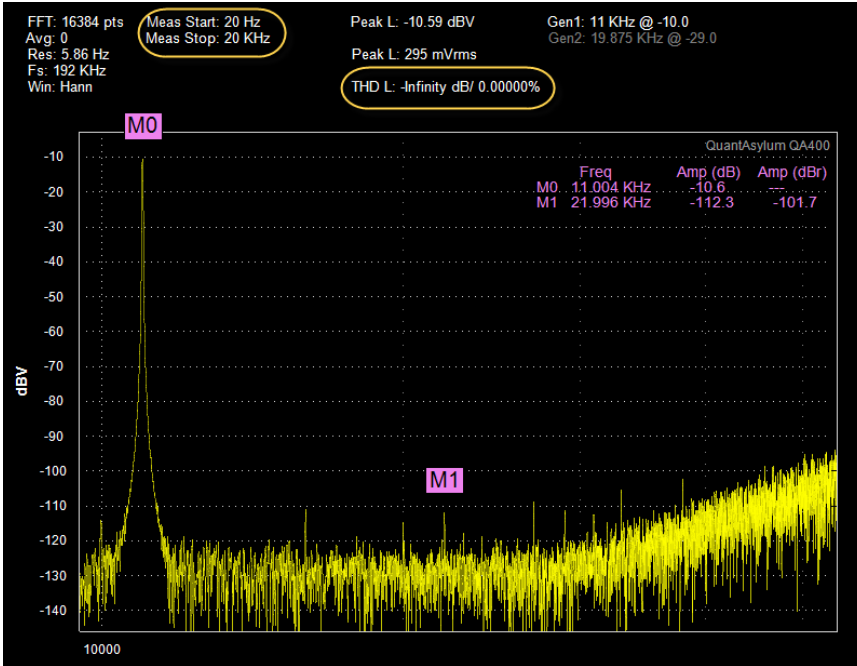

THD Context Menu

The THD context menu is very simple, and allows you to set the Measurement Start and Stop limits. Note these are the same limits that are set in the Power context menu. Additionally, you can specify what will be used for the fundamental.

QuantAsylum QA401 User's Manual

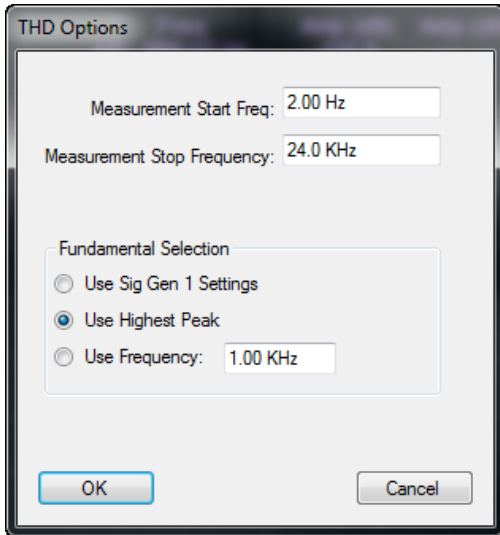

Because the fundamental selection is so important, it's important that you can readily see what the software has selected for the fundamental frequency. Notice below that a small green 'F' has been drawn near the X axis. This way you can be certain that the software is picking up the peak you want, and not some other signal.

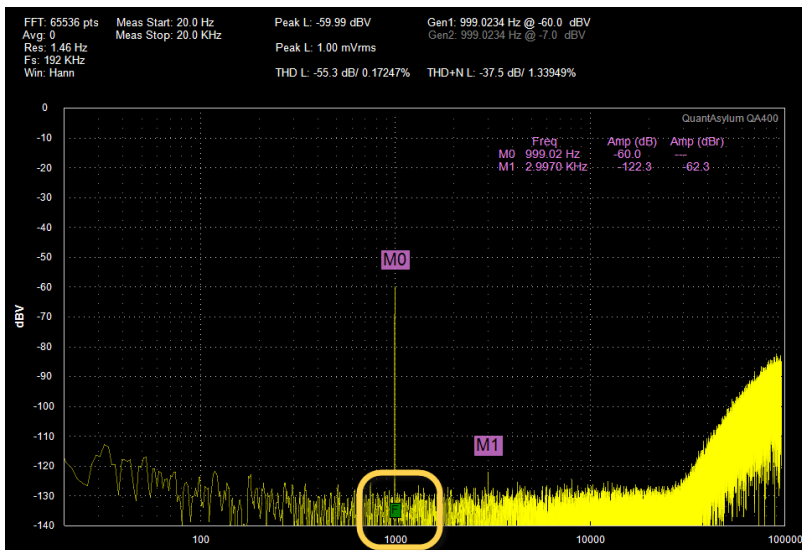

THD + N

The THD + N measurement is enabled using the button on the panel. THD+N is similar to the THD measurement, but instead of looking at just the harmonic power, all of the non-fundamental power is considered in the specified bandwidth.

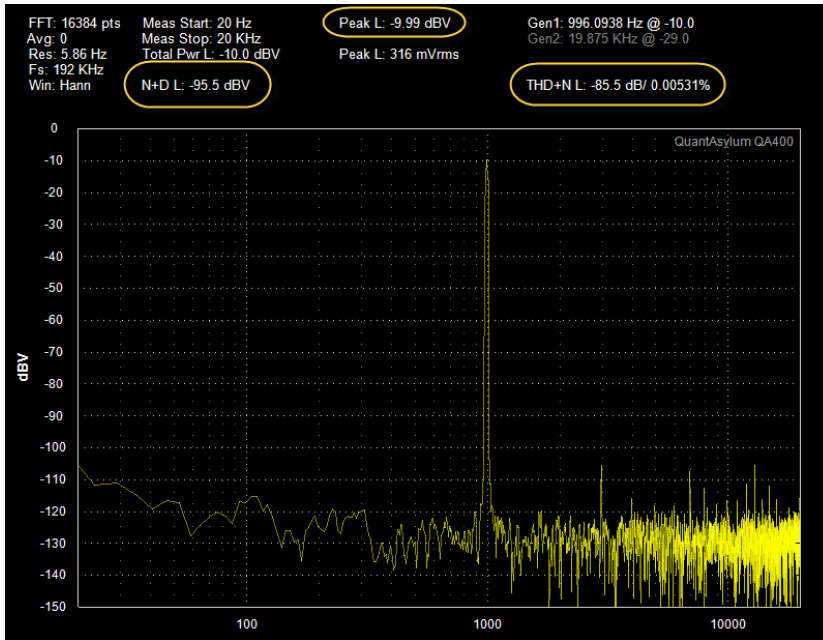

Notice the relationship between the highlighted numbers above. The peak value is -10 dBV (which is the level of the signal generator), and Noise + Distortion is measured as -95.5 dBV, and thus this means the ratio of the signal to the noise and distortion is -85.5 dB, which is what is reported in the THD+N calculation.

Frequency Response

The QA401 offers a quick way to look at the frequency response of a device under test (DUT). This is achieved with the Frequency Response (FR) button. The context menu for the Frequency Response button appears as follows:

QuantAsylum QA401 User's Manual

Frequency Response Settings

Stimulus Settings

Stimulus: ExpoChirp ▼

Amplitude (dBV): -35.0

Display Phase

Expo Chirp Options

End Frequency: 24000

Octaves: 10

Window (mS): 10.0 (0 = disabled)

Smoothing (Octaves): 1/3 ▼

Harmonic Display 2H 4H
 3H 5H

Mask Settings

Freq Response Mask Load Clear

Display Pass/Fail

OK
Cancel

There are five types of stimuli available:

Impulse	The impulse response is a single sample centered in the output buffer with the specified amplitude. Because the energy of an impulse is so low, it's primarily useful in evaluating circuits that are directly wired to the QA401. Attempting to measure frequency response with an amplified impulse played through speakers and captured by a microphone can be challenging because there is so little recovered energy.
Expo Chirp	This is an exponentially swept sine, covering 10 octaves, with the final frequency being 1.0 * Nyquist (eg 24 kHz @ 48 ksp/s). The energy of the exponential chirp is much higher than the impulse, but you might experience some ragged edges at very low and very high frequencies depending on your FFT size. An exponentially swept sine will spend as much time sweeping from 20 to 40 Hz as it does sweeping 10 to 20 kHz. This ensure good dwell time at lower frequencies. Overall, this is the preferred stimulus for most work.
Linear Chirp	This is a linear swept sine, swept from 20 to 20 KHz regardless of sample rate. Because the sweep is linear, the dwell time at higher frequencies suffers and the response can become ragged at higher frequencies. The benefit of the linear sweep is that equal time is spent at all frequencies.
White Noise	This is white noise originated from the DotNet random number generator. White noise can be useful in very "live" rooms with lots of reverberations. Remember that while the QA401 has a log and linear X axis display option, the frequency spacing is <i>always</i> linear. Thus, regardless of the X axis display setting, white noise will always appear flat on the spectrum display.

QuantAsylum QA401 User's Manual

Generally, the Expo Chirp is what you'll want when sweeping the frequency response of a circuit or speaker. Below is the response plot of a 30 dB amplifier from 2 to 100 kHz. Note the FFT size is 64K. Larger FFTs will might help with low frequency response. But be careful placing too much confidence in chirp response at the frequencies below the start frequency as there's likely not enough energy present to make a meaningful measurement.

In the plot below, the declining response around 3 Hz is due to the input capacitors (DC blocking caps) on the QA401 input. We can see the upper 3 dB point is between 55 and 60 kHz. In this case, the upper-end rolloff is coming from the external 30 dB amplifier.

Remember, impulse response and chirps are great tools for quickly looking at frequency and phase response. But for the best accuracy, consider stepped sine if time isn't critical.

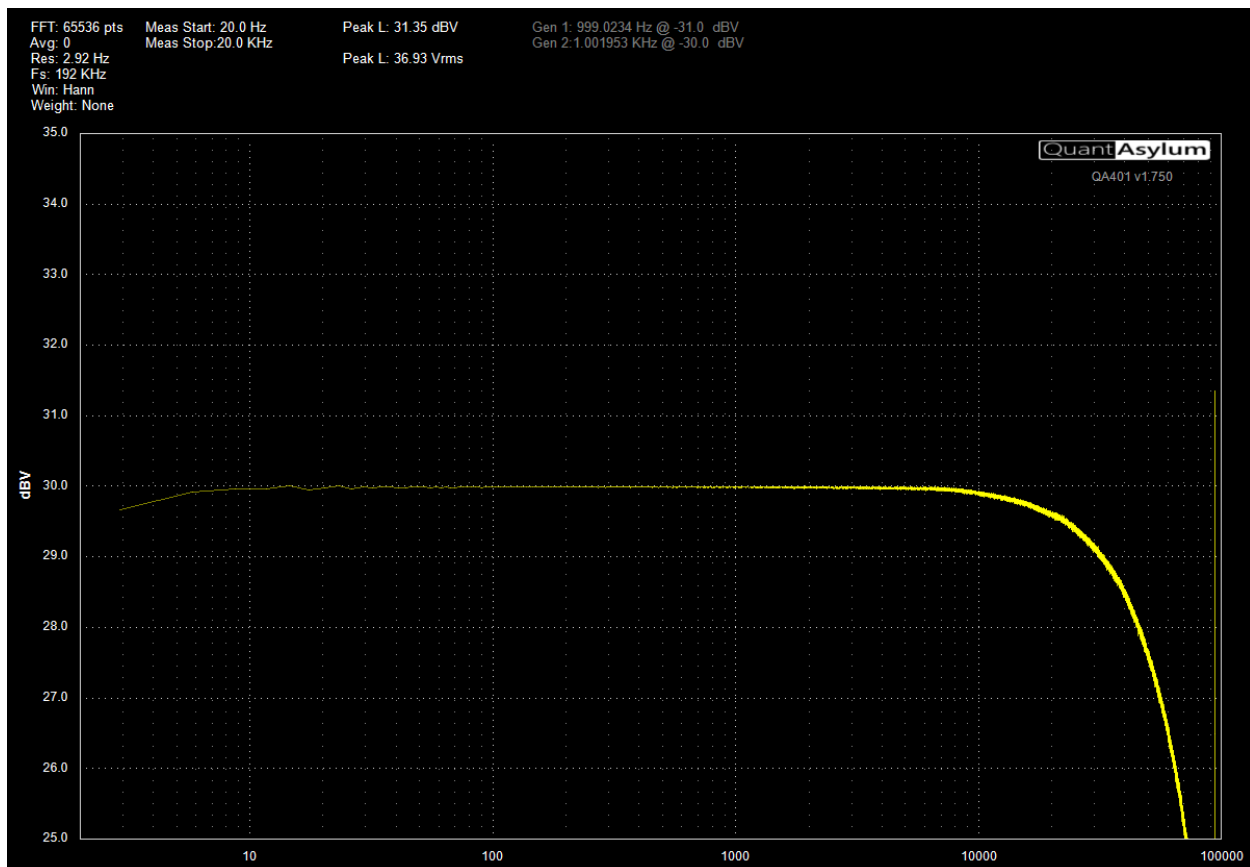

When displaying a response using either linear or exponential sweep, the QA401 performs what is commonly known as a “two FFT” measurement. This means that the frequency response is derived by performing a complex division the measured output of the DUT with the input to the DUT. This result gives you the transfer function (frequency response) of the DUT which is then displayed on the screen. From this response, a channel impulse can be determined via an inverse FFT.

When selecting Expo Chirp, you are given some additional options that can be set. When you set the Window Time parameter to a non-zero value, this will perform a windowed FFT on the channel impulse

QuantAsylum QA401 User's Manual

response. The Windows (mS) time setting refers to the amount of time after the impulse peak occurs that the data will be accepted. Data arriving after the specified window time will be rejected. When a zero value is set, then the entire impulse response will be considered.

As you increase the measurement window, you increase the reliability of the low-frequency measurements. If you have a 1 mS measurement window, then measurements occurring at $1/1\text{mS} = 1$ kHz and below will be unreliable. If you have a 10 mS measurement window, then measurements occurring at $1/10\text{ mS} = 100$ Hz and below will be unreliable.

Obviously, a larger window is desired. But if you set the window too large, you run the risk of having room reflections spoil your measurement. If you have a speaker placed on the floor firing towards an 8-foot ceiling, and the microphone is placed 2 feet above the floor, then the path to the microphone is about 2 feet directly, and about 12 feet indirectly. That is, from the microphone to the ceiling is 6 feet, and for sound from the speaker to bounce off the ceiling and return to the microphone it must travel 12 feet. Sound travels at roughly 1 foot per second, and so in this configuration, we could specify a <12 mS window and ensure that all ceiling reflections are omitted from the measurement. The same math would need to be done with the walls. But in short, if a speaker is placed on a floor and all walls and furniture are 5 feet or greater from the speaker, then you can comfortably specify a 10 mS window. This will give you a reasonable measurement down to 100 Hz or so.

Once you have your room measurement set up, you can start running and verify the window is working as desired: A large reflecting surface outside of your time window shouldn't influence the measurement. For example, if you have set a 10 mS window and ensured all sources of reflection are > 5 feet away from the speaker and mic, then holding a large sheet of cardboard 6 feet from the speaker shouldn't influence the valid portion of the response ($1/10$ mS means those frequencies above 100 Hz). But as you approach the measurement with the cardboard sheet and step inside the 5 foot radius, you will start to see the measurements above 100 Hz being impacted by the reflections from the cardboard.

You also can set smoothing parameters, from $1/96$ kHz octaves (minimal smoothing) to $1/1$ octaves (maximal smoothing). The smoothing performed is rectangular.

The implication of the above are common in all measurement software. The practical details are as follows for mic'd versus unmic'd measurements.

Unmic'd measurements

If you are making a direct measurement (that is, there is no microphone involved), then an expo-chirp is probably the best way to quickly determine the circuit response. For the most accuracy near the edges, consider a stepped-sine measurement, such as the "AMP FrequencyResponse" plugin. For this measurement, you'd usually want minimal smoothing ($1/96$) and you'd always want no windowing (0.0 mS) since you needn't worry about reflections. This will give you the best resolution at the band edges.

Mic'd measurements

If using the expo chirp in a mic'd setting (such as measuring a speaker response), then you'd want to specify a window based on the reflection times you are able to provide. Additionally, you will want to

QuantAsylum QA401 User's Manual

apply more aggressive smoothing—speaker measurements are typically using about 1/24th Octave for engineering plots, and 1/3rd Octave for marketing literature.

Note that for mic'd measurements you'd also want to specify a [microphone calibration file](#).

Generators

The QA401 has two tone generators. Each tone generator has knobs so that the mouse can control the amplitude and frequency settings. This is useful when you are interactively looking at circuit performance and want to change values on the fly.



The generators are enabled using the Gen1 and Gen2 buttons. Each generator also has a context menu. From the context menu, you can set a precise frequency. If you select “Round to Eliminate Leakage”, then the frequency you select will be nudged a bit higher or lower to ensure that it sits precisely in the center of a frequency bin. This will dramatically reduce the amount of leaking you are seeing. Generally, the amount the frequency will be nudged will be no more than the resolution of your current FFT size and sample rate.

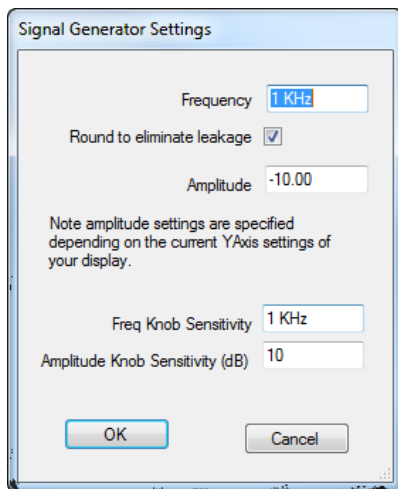

When the rounding occurring, you will see the rounded frequency in the Generator display at the top of the waveform window. In the picture below, we specified a 1 KHz waveform, enabled rounding, and the frequency was adjusted automatically to 996.0938 Hz.

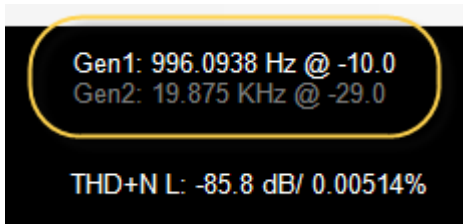

The amplitude of the generator will always be specified in the current units of display. For example, if you have specified dBV, then the amplitude you enter will be in dBV units. When you switch to another units (such as dBFS), then value you entered will automatically be converted to the new units.

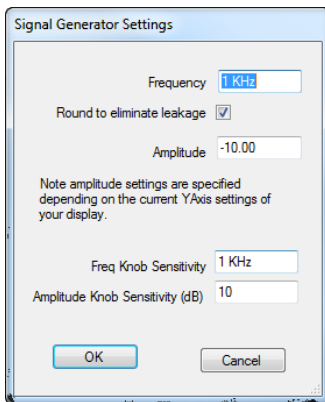

The frequency and amplitude knob sensitivities allow you to specify how much each value will change when you rotate your mouse wheel above the Freq and Amp knobs. And again, if you press the control key while adjusting the knob, the knob will spin 10X faster. And if you press the shift key while adjusting the knob, the knob will spin 10X slower.

IMD Measurements

The primary purpose of the dual-tone generators is to permit IMD measurements. While the QA401 doesn't perform automatic IMD measurements, they are easy to perform manually. A typical IMD test would be the IMD ITU-R test. This requires applying two tones of equal amplitude spaced 1 KHz apart. Usually, the tones are 19 KHz and 20 KHz.

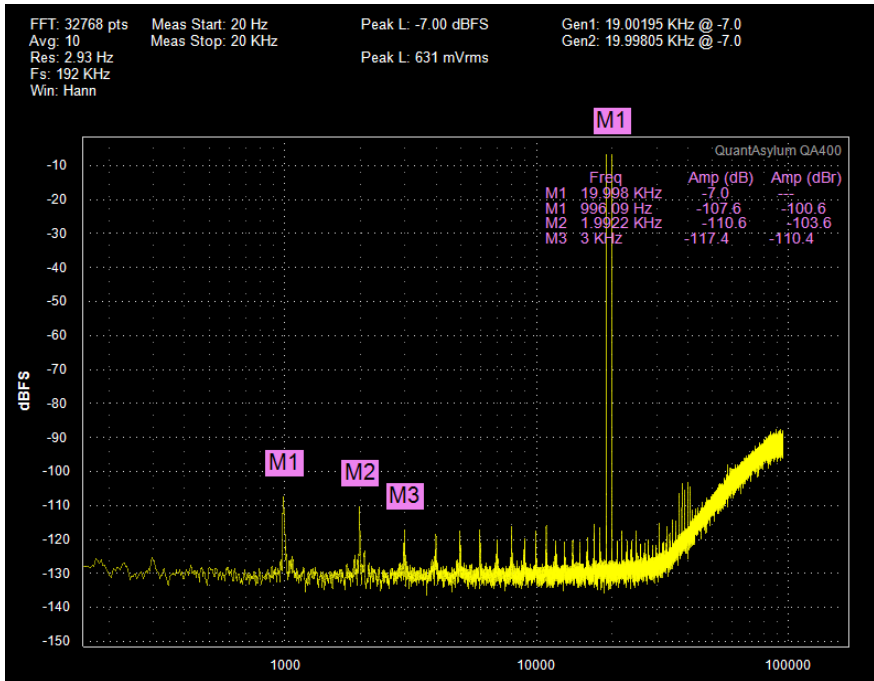

In the plot above, you can see the 19 KHz and 20 KHz tones applied at -7 dBFS, and the resultant mixing product that shows up at 1 KHz, 2 KHz, etc. As the marker shows, the 1 KHz tone is roughly 100 dB below the input tones, and thus the IMD shown is roughly 0.001%.

Another common IMD measurement is commonly known as the SMTPE IMD measurement. This involves a low frequency signal (usually 60 Hz) and a high frequency tone (usually 7 KHz), with the lower frequency being 4 times greater (12 dB). Below we see both tones.

QuantAsylum QA401 User's Manual

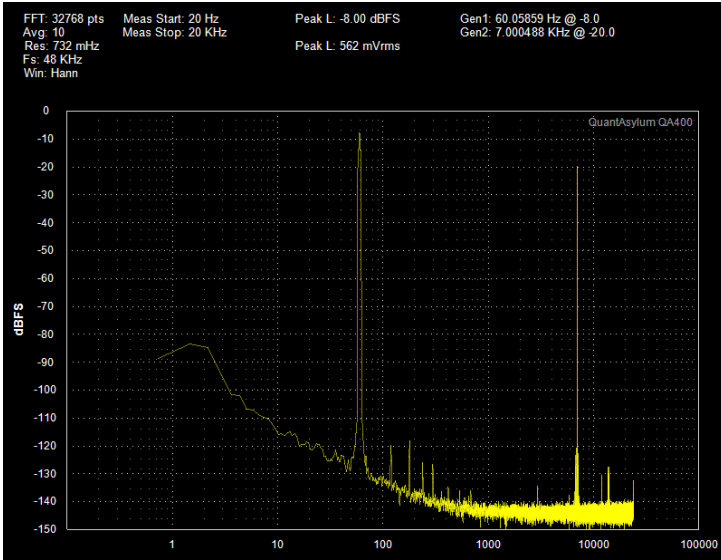

Notice we're at 48 Ksps sampling rate and 32K FFT, as this gives us less than 1 Hz resolution.

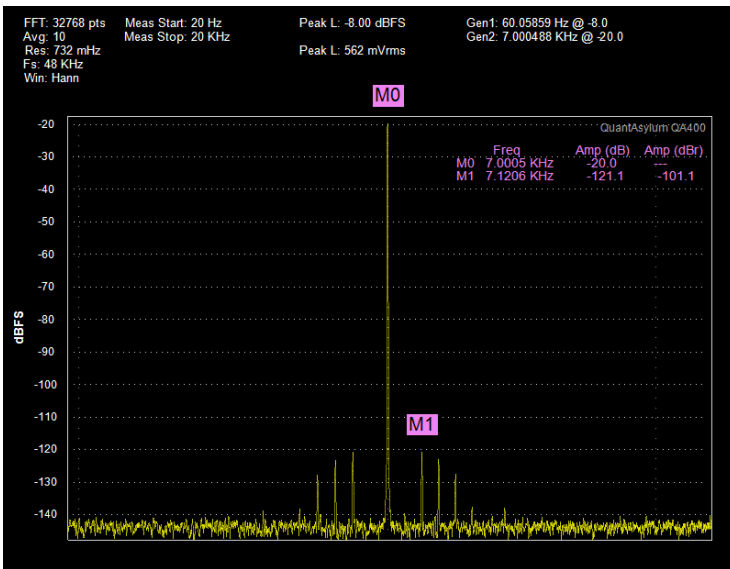

The region of interest are the IM products around the 7 KHz tone. Zooming in, we can see these in detail, thanks to the high resolution FFT in the plot above.

Notice the 7 KHz +/- 60 Hz harmonic is tightly suppressed. But the second harmonic of the 60 Hz shows up (and +/- 120 Hz) and that level is shown to be about -101 dB below the 7 KHz tone.

Power Supply Noise Measurements

A common measurement to make is the output noise of a power supply. Recall the max DC input limit previously discussed: It is critical to keep DC levels within +/-5V at all times, even if the attenuator is engaged. Even though the input is AC coupled, connecting higher voltages will cause protection diodes to activate for very short periods of time and the brief, high-current flows could damage the input stage.

The QA401 with the inputs shorted will report a 20 to 20 KHz noise reading of roughly -115 dBV, which is about 1.8 uV RMS. This is the lower bound of power supply noise that can be measured. Typical LDOs will exhibit noise in excess of 50 uV in the audio band, while ultra low-noise LDOs will approach the limits of the QA401 in very rare cases. State of the art today for LDOs is below 1uV in the audio band.

The safest way to measure the noise of a power supply is to use a resistor divider to drop the power supply voltage to under 5V. For example, if you wanted to measure a 48V power supply you could use a 1/10th divider (20 dB) comprised of a 100 ohm lower resistor and a 900 ohm upper resistor. You'd then report in the QA401 an external gain of -20 dB. This would be done in the Axis Settings button marked dBV context menu as shown below

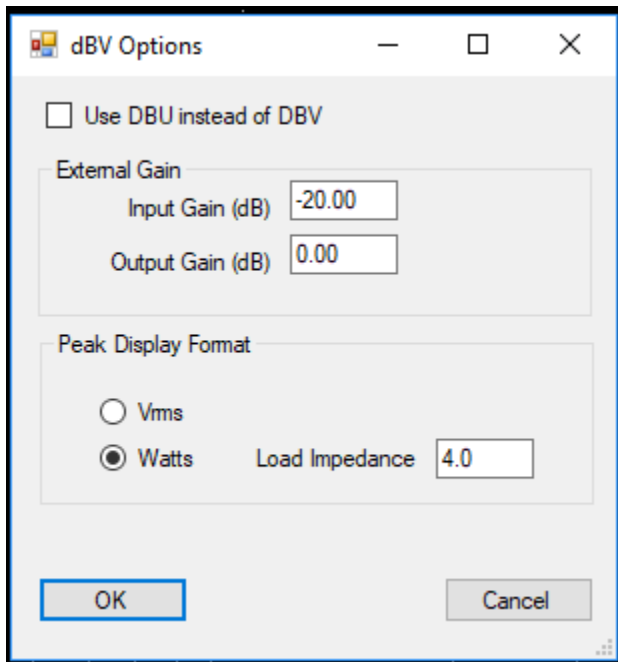

This would raise the apparent noise floor of the QA401 to about 18uV. This means that if your supply was 48V and had an expected noise measurement that was less than 18 uV, this technique wouldn't work. But higher voltages supplies that require this level of noise are rare.

For a 15V supply, if you used a 1/3 divider (-9.55 dB), the measurement noise floor would be about 5.4 uV (20 to 20 KHz) while keeping the input at or below the 5V limit.

Feel free to contact us at the support email if you'd like help in selecting values for the divider.

Settings

The settings menu allows in-frequent settings to be adjusted.

General

The General dialog is used to adjust the system sample rates. The 192 Ksps will be more demanding on hardware resources, and as a result might not be usable on older or slower systems.

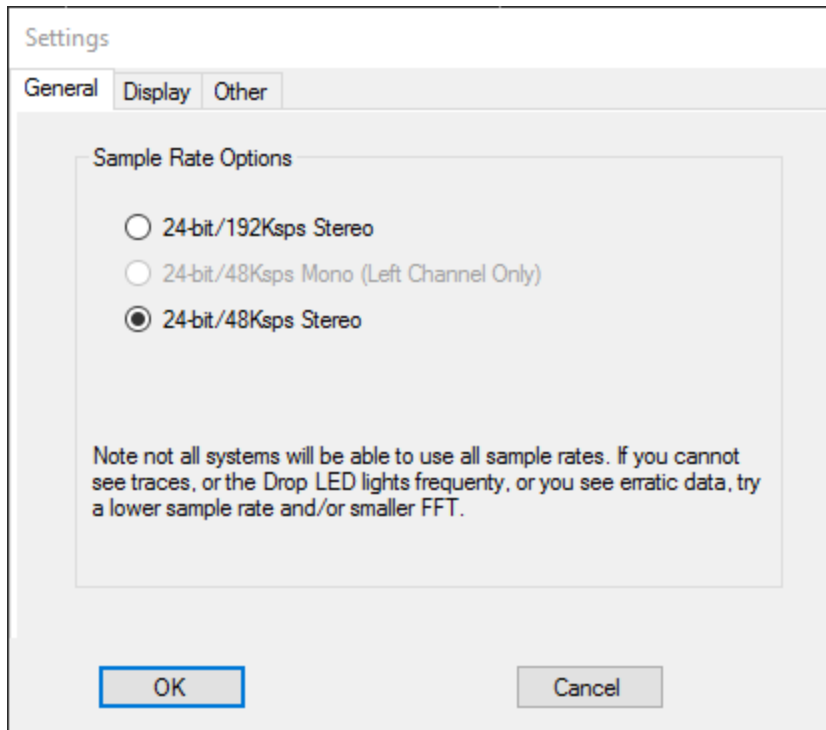

Display

The Display tab allows you to set “Dark on Light” color scheme. This is more suitable when you need to create plots that can be printed.

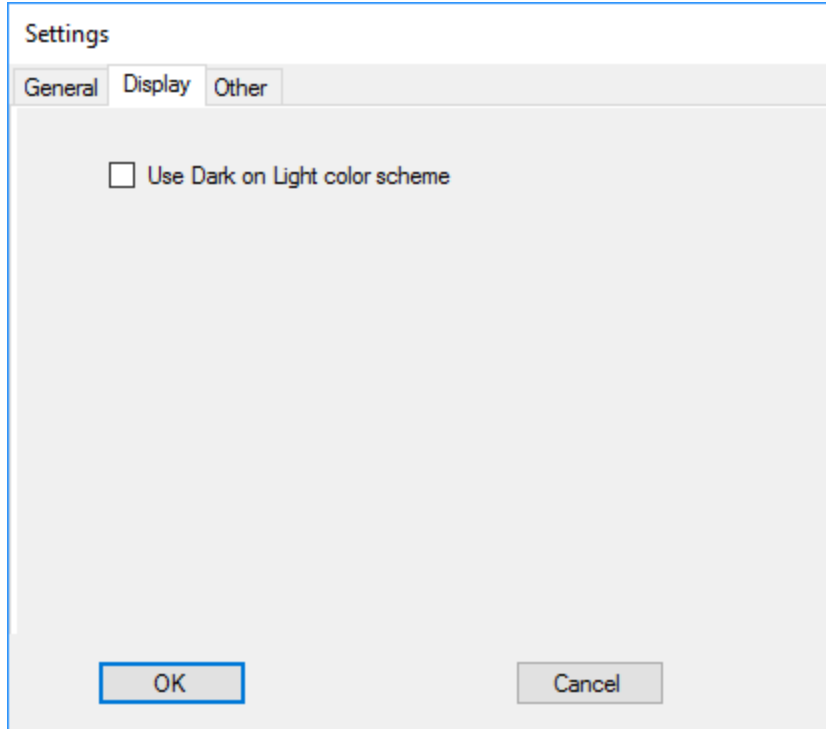

Other

The last tab of the dialog allows you to make adjustments for some unique test cases.

Latency Compensation

Latency Compensation allows you test devices that might have longer processing delays. For example, if you are testing a codec or a system that involves digitization and transmission/reception, then there could be 50 mS or more of latency in the path. Because the QA401 operates on bursts, the length of the burst might be not long enough. That is, the burst might not have even arrived back at the input ports when the QA401 expects it.

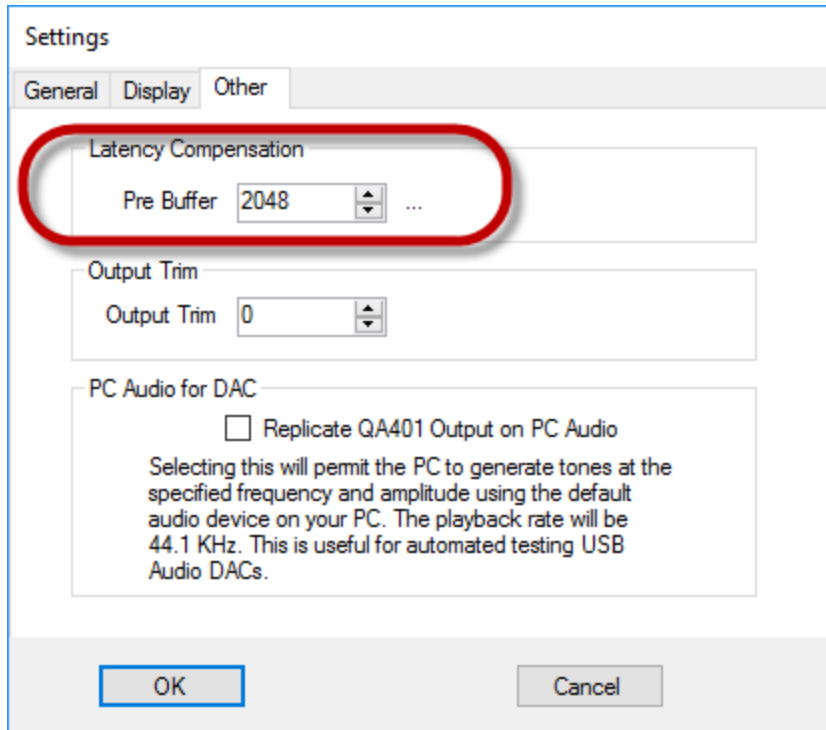

The solution here is to increase the previously discussed “constant amplitude” region of the burst (shown below in red). Before the 1.50 release, the only way to increase the constant amplitude region of the burst was by increasing the FFT size. With the 1.50 release and later, the ability to increase the pre-buffer will permit the burst length to grow.

Keep in mind the latency compensation depends on the current sample rate. Set your sample rate before you adjust the latency compensation, and you will see the max latency computed adjacent the pre-buffer setting. If you change sample rate, the buffer size will stay constant, but the latency compensation will change.

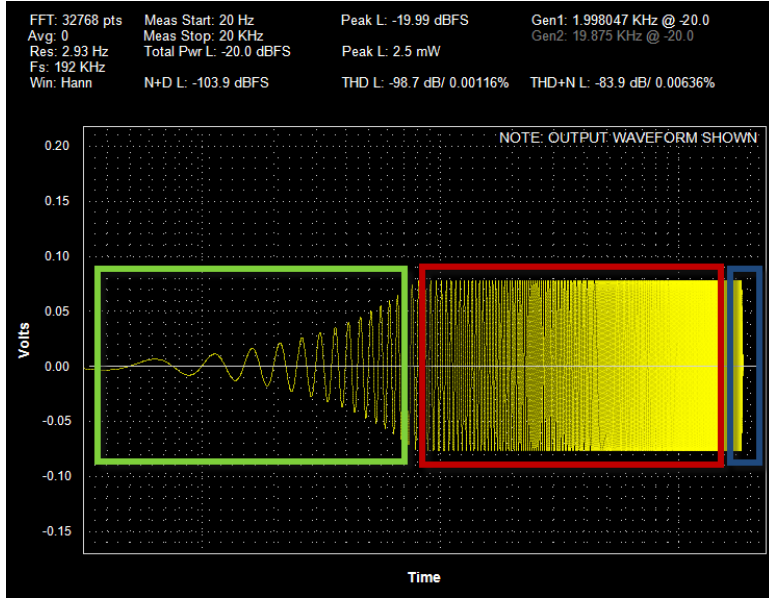

Output Trim

Output trim allows you adjust the output offset of the DAC. With the QA401 in the Stop mode, you can measure the output of a BNC (relative to its outer conductor) and you'll notice a slight offset around 1 or 2 mV. By adjusting the output trim, you can null that reading to very near zero. The reading is shared among the 4 outputs (Left+ and Left- and Right+ and Right-). The output offset is due to DAC offsets (the dominate source) and opamp offsets (generally around +/- 100uV).

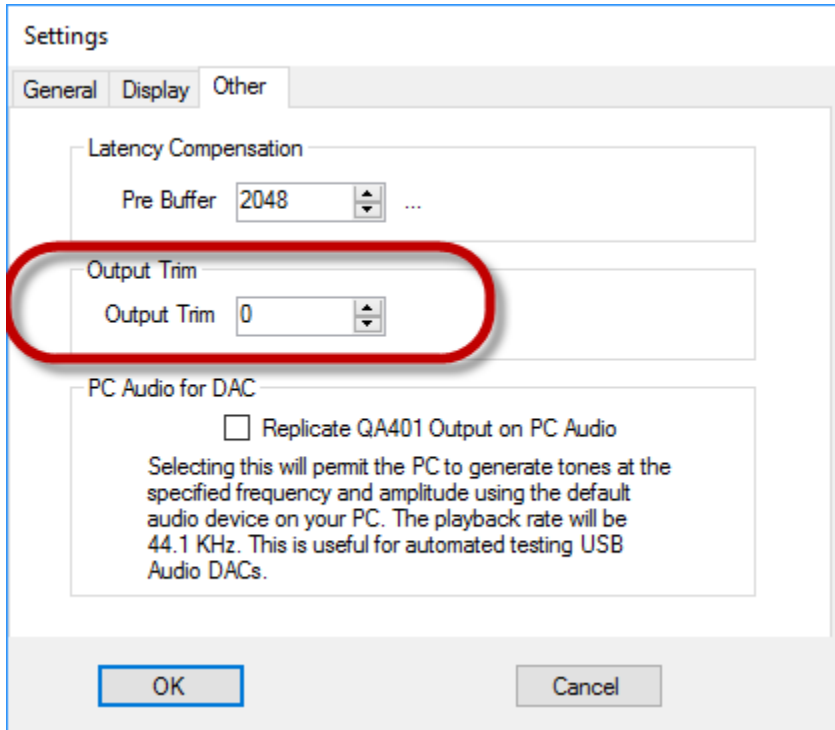

QuantAsylum QA401 User's Manual

PC Audio for DAC

Manual tests on an audio DAC connected to a PC are easy to do, because you can play tones on the DAC and measure those tones on the QA401. But automated testing of a DAC requires that the QA401 can control the DAC amplitude and frequency.

When the checkbox "Mirror QA401 Output on your PC" is checked, then the adjustments made to the QA401 Gen1 amplitude and frequency will also be made on the default audio output device on the PC at the time the QA401 application was launched (mirroring doesn't work for dual or multitone). The main display will also indicate "Mirror" in the upper left area of the display.

There are a few things to keep in mind here:

First, the PC amplitude of the PC isn't known or calibrated, and thus when you specify a tone level of 0dBFS, the PC will generate a maximum value tone. Since the QA401 has a max output just shy of 6 dBV, you can roughly subtract 6 dB from your Gen1 output settings to learn the value that is being sent to your soundcard when mirroring is enabled. For example, if the QA401 Gen1 is set to -10 dBV, then the level being sent to your mirrored PC audio DAC will be -16 dBFS. You could also see this by switching to dBFS in Axis Settings.

Second, the PC audio will start and stop along with the QA401 audio. When the frequency or amplitude is changed on the QA401, either directly or via the API, the change will also happen to the PC audio. Whenever mirroring is enabled, then any changes to the QA401 frequency or amplitude will experience a slight delay while the PC audio settles. If you find that during automated sweeps you are seeing two tones present in the spectrum then what is most likely happening is that the frequency of the PC tone was changed and the acquisition was started before the PC had fully changed the frequency (or amplitude). In order to compensate for that, you can increase the "Freq/Amp Change Pause" shown in the settings dialog below.

Finally, keep in mind the PC audio must be the default audio device in the system. Also understand that if another application generates sound, then that sound may very well be played from the DAC you are testing. For example, if you start a sweep on your DAC, and then go to File Explorer and start looking for a picture, the clicking in the File Explorer will generate sounds as you navigate the directory structure. Those sounds will contaminate your measurements. Additionally, your output device might be transcoding sample rates on the fly, which can result in unexpectedly poor performance. In short, be careful when testing DACs. Careful configuration of the DAC is required to ensure it's in the mode you expect and not being compromised by other applications or settings.

A blog post on measuring a PC DAC is located here: <https://quantasylum.com/blogs/news/rapid-dac-evaluation>

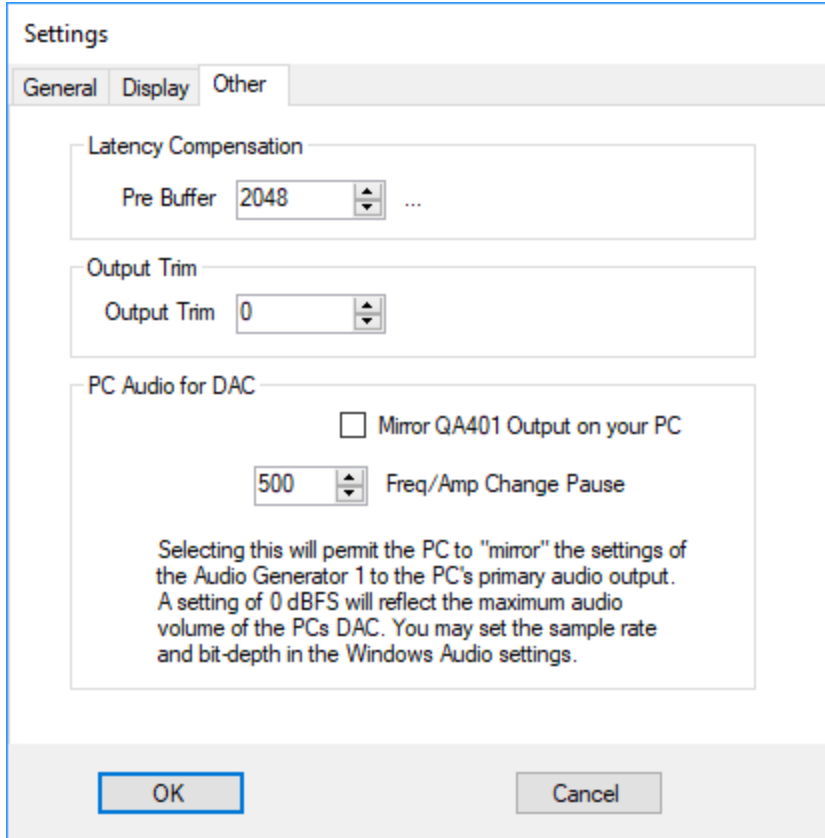

Setting : Audition

In the Settings menu, the Audition options allows you to use the QA401 to play a WAV file. The WAV file must be prepared so that the sample rate is the same as the currently selected sample rate. The dialog for Audition appears as follows. Once you've selected the file, it will be converted into a format suitable for the QA401 and then you'll have the option to play the file. The volume may be adjusted, and the volume setting is simply a multiplier applied to the samples inside the wave file.

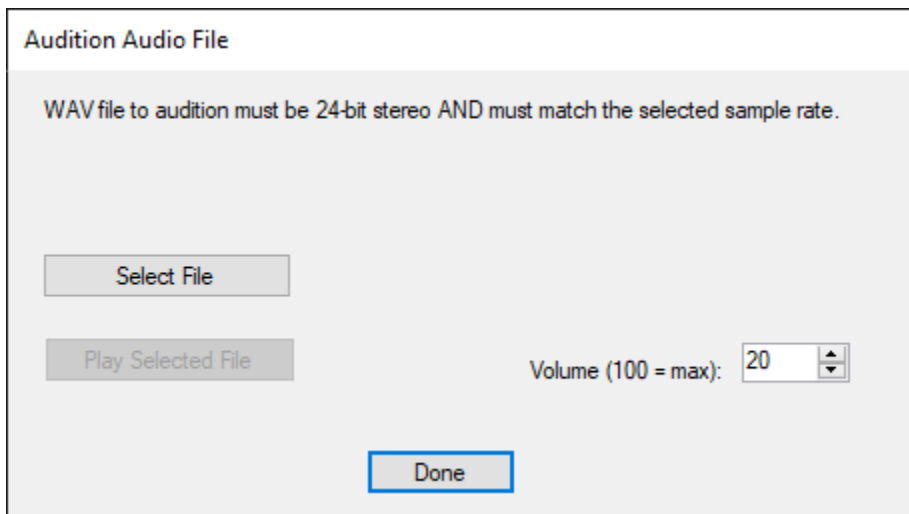

Setting : Generate Fixed Tone

There are times when it's useful to generate a fixed tone of a specified level, especially when checking the settings with a DVM. The QA401 can generate a fixed tone, without bursting, in the Settings -> Generate Fixed Tone option. Here you can select the frequency and amplitude in dBV.

Be aware if using a DVM to check the level that many DVMs will start rolling off before 1 kHz. It is always good to check the level with a 60 Hz frequency, as all DVMs will hit their rated accuracy at that frequency. And then, compare that to the measurement at 1 kHz. That will help you understand whether your DVM accuracy can be trusted at 1 kHz.

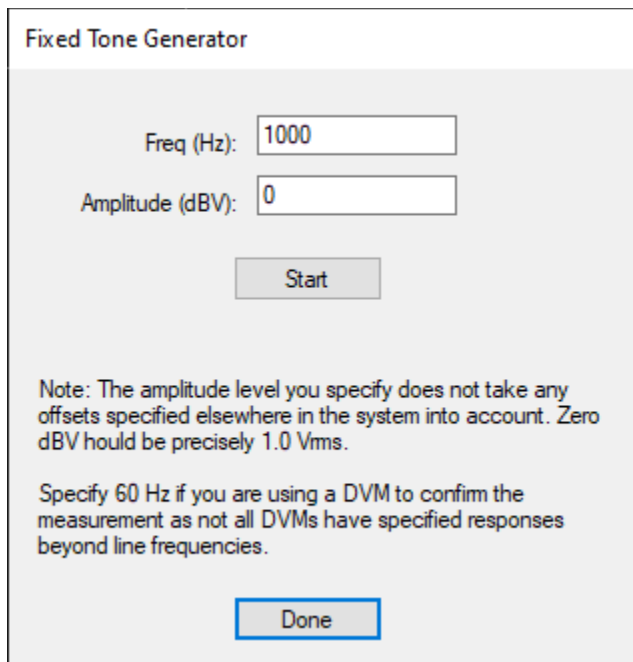

Fixed Tone Generator

Freq (Hz):

Amplitude (dBV):

Note: The amplitude level you specify does not take any offsets specified elsewhere in the system into account. Zero dBV should be precisely 1.0 Vrms.

Specify 60 Hz if you are using a DVM to confirm the measurement as not all DVMs have specified responses beyond line frequencies.

Edit: Copy Bitmap to Clipboard

If you are preparing a report, it's often helpful to be able to capture the same sized image regardless of the size of the application window. In the Edit menu, this can be done with the Copy Bitmap to Clipboard item. You will have a few options for bitmap sizes offered, and the captured bitmap is placed on the clipboard making it easy to paste into a report or other application.

Edit: Snapshot

It is often handy to capture a trace and display it while making another measurement for comparison. In the Edit menu you can capture either the left or right trace data and then overlay that data with a new measurement to make for an easy visual comparison. Note that the measurement parameters such as FFT size must be same.

QuantAsylum QA401 User's Manual

To capture the current left-channel trace, select Edit : Snapshot : Snapshot Left Channel Data. The same can be done for the right channel. The softkey 'L' and 'R' can be used here too. The snapshot data will be shown in green. It can be turned off by apply the sequence again. That is, if you used 'L' to snapshot left channel data, then it can be turned off by pressing 'L' again.

Test Plug-ins

Plug-ins allow you to run stepped testing on a device-under-test.

When running plug-ins, it's important to remember that the current settings are used except for cases where you may specify settings in the plug-in.

The naming of each plug-in has been changed to indicate better indicate what the plug-in does. The plug-in menu drop-down now appears as follows:

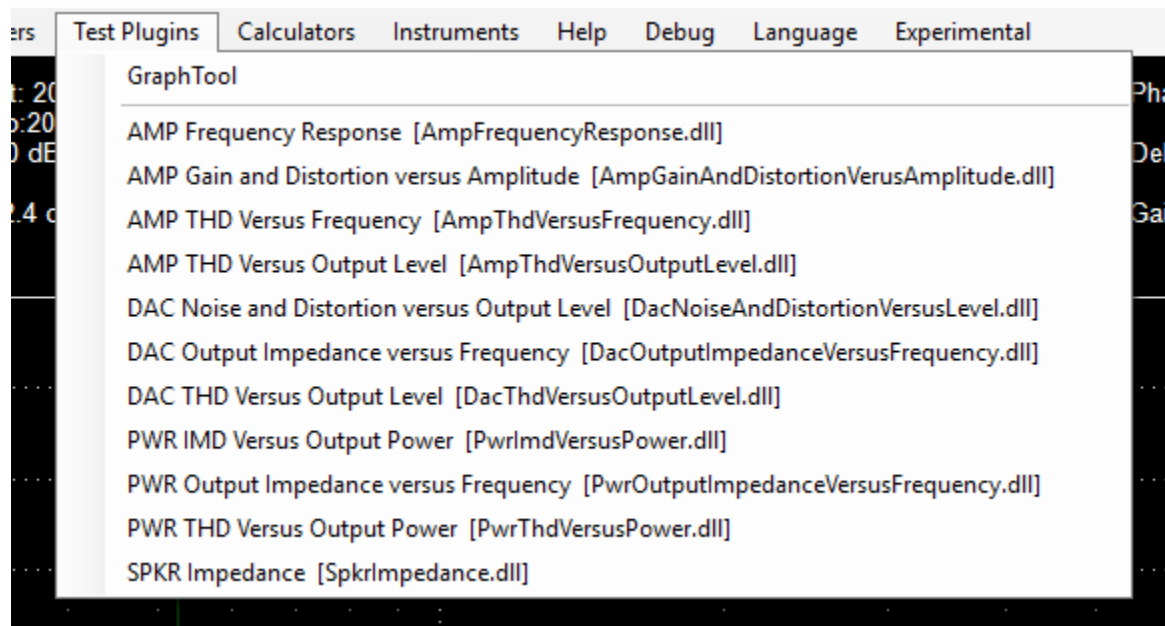

There is a prefix to each plug-in:

AMP: This plug-in will deal in dBV both in and out, and is useful for testing amplifiers when you aren't concerned about the power. For example, a pre-amp or individual op-amp circuit would make sense for this plug-in. But it can also be used on power amplifiers, depending on the units of measurement you want to see.

DAC: This plug-in will express output as dBFS and will require that [Mirror mode](#) is enabled in the QA401 application.

MIC: This plug-in is designed for measuring microphones.

QuantAsylum QA401 User's Manual

PWR: This plug-in is designed for measuring power amplifiers. Output levels from the QA401 will be expressed in dBV, and input levels will be converted to watts. This requires you to specify a load.

SPKR: This plug-in is designed for measuring speakers.

For each of the plug-ins below, you can see the settings options and also a typical graph output from that sweep.

In some cases, external gains can be specified. This is useful if you are using an external attenuator. Setting the correct value here will ensure the displayed measurements are correct. For example, if you are using a QA450, which has 6 dB of attenuation built in, and you aim to measure gain versus frequency using the Frequency Response plugin, then you would specify there is an external gain of -6 dB. If the output of the amplifier you measuring is -10 dBV, and you have an external 6 dB attenuator, then the level hitting the QA401 inputs is -16 dBV. By specifying an external gain of -6 dB, then reported value will then be adjusted to -10 dBV for display on the graph.

This value operates independently from any external input/output gain specified in the DBV context menu.

AMP: FREQUENCY RESPONSE

The options dialog appears as follows:

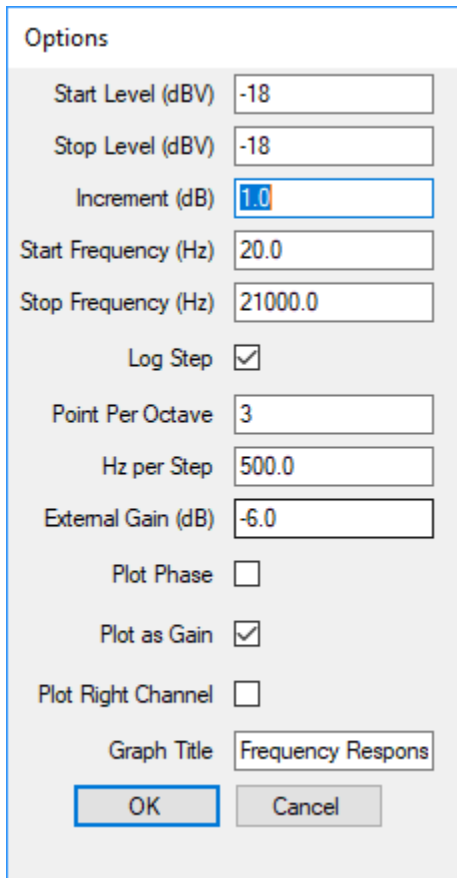

The screenshot shows a dialog box titled "Options" with the following settings:

- Start Level (dBV): -18
- Stop Level (dBV): -18
- Increment (dB): 1.0
- Start Frequency (Hz): 20.0
- Stop Frequency (Hz): 21000.0
- Log Step:
- Point Per Octave: 3
- Hz per Step: 500.0
- External Gain (dB): -6.0
- Plot Phase:
- Plot as Gain:
- Plot Right Channel:
- Graph Title: Frequency Respons

Buttons: OK, Cancel

Typical output might appear as follows:

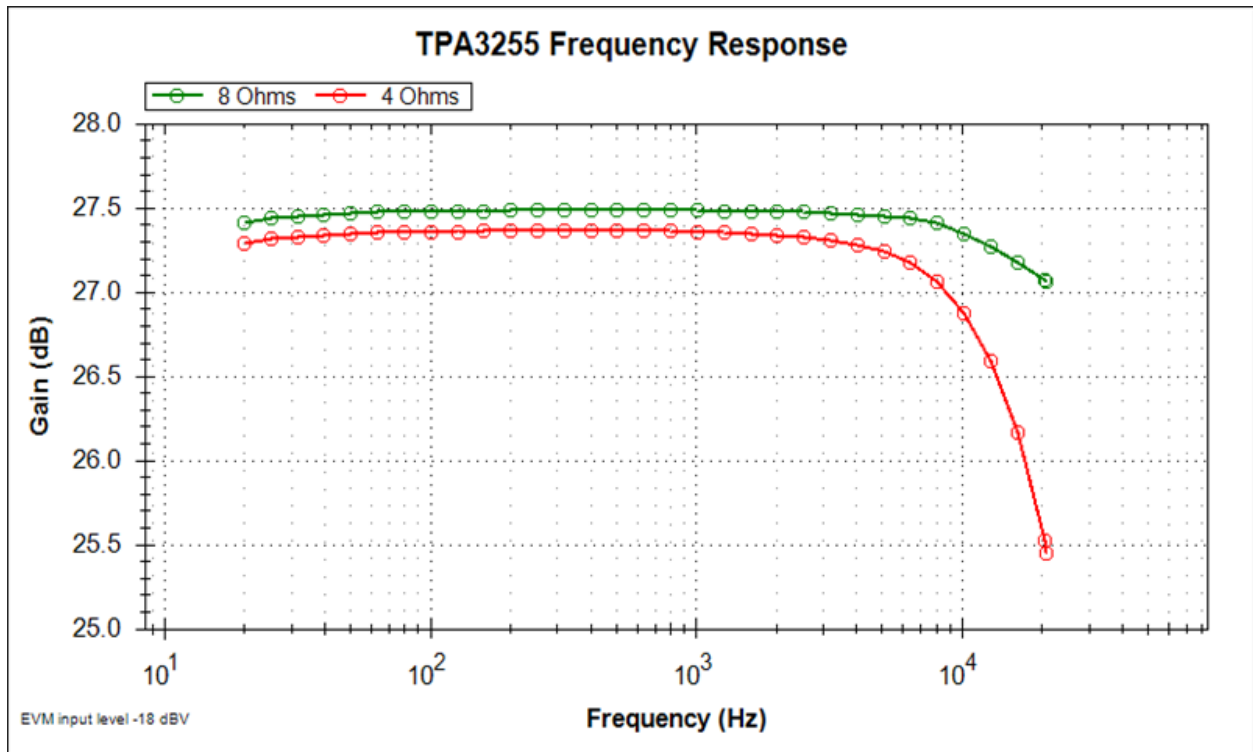

AMP: FREQUENCY RESPONSE CHIRP

Generates a graph that is like the AMP FREQUENCY RESPONSE plug-in above, but this plug-in uses a chirp, which is much faster (but slightly less accurate and band edges).

The options appear as follows:

Options

Help

Output Level (dBV)

1/Smoothing

Plot Right Channel

Plot Phase

Plot as Gain

External Gain

Series Name

QuantAsylum QA401 User's Manual

Smoothing is expressed as 1/Octaves. For example, if you desired 1/12 octave smoothing, you'd enter '12' in the field. Generated graphs are similar to the AMP: FREQUENCY RESPONSE plug-in.

AMP: GAIN AND DISTORTION VERSUS AMPLITUDE

The options appear as follows:

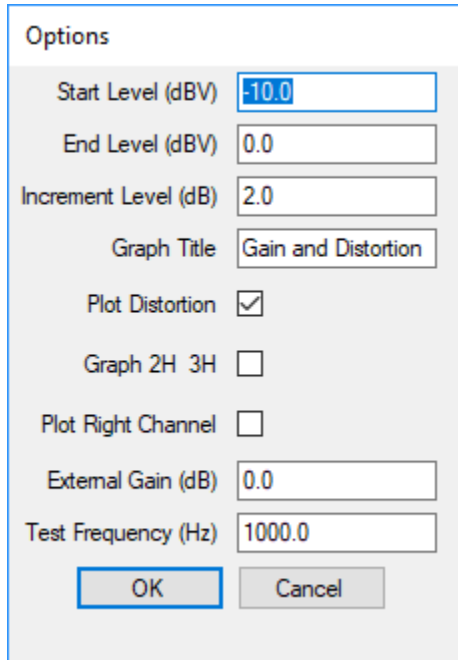

The image shows a dialog box titled "Options" with the following fields and controls:

- Start Level (dBV):
- End Level (dBV):
- Increment Level (dB):
- Graph Title:
- Plot Distortion:
- Graph 2H 3H:
- Plot Right Channel:
- External Gain (dB):
- Test Frequency (Hz):
- Buttons: and

The output appears as follows. The left Y axis shows the gain of the DUT, and the right Y axis shows the distortion of the DUT, with the option to plot 2H and 3H levels separately.

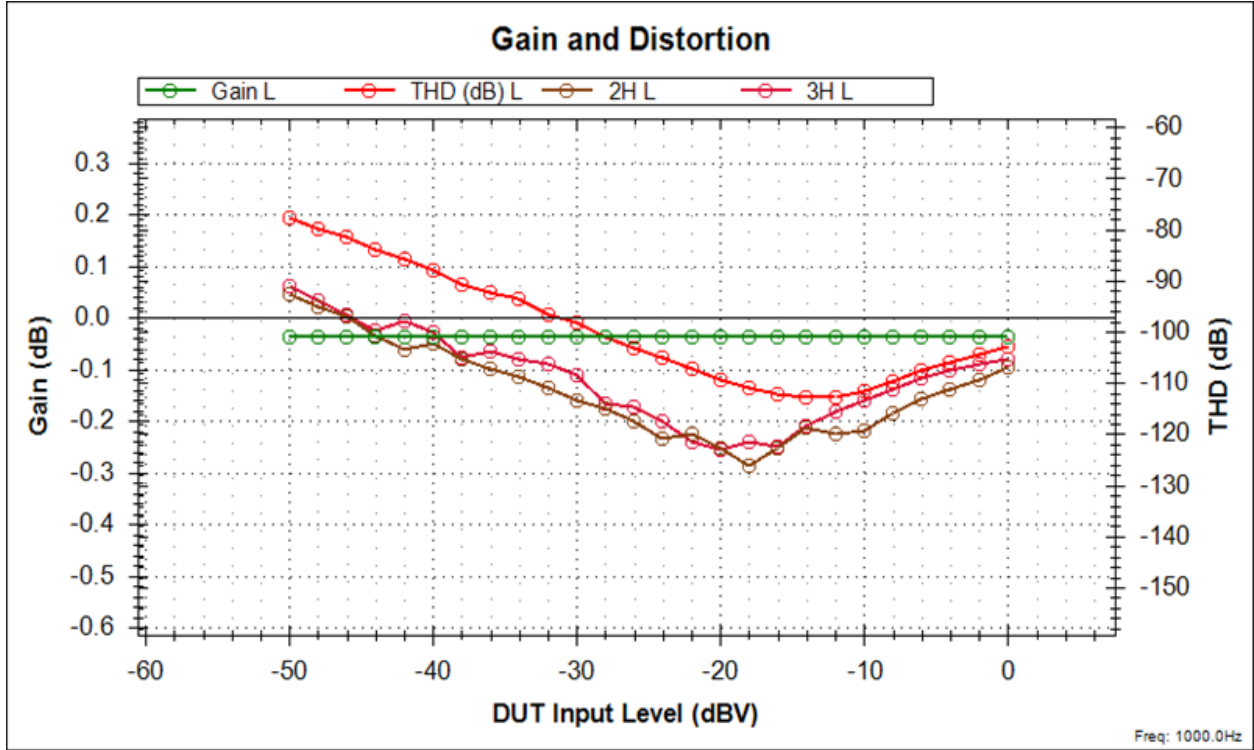

AMP: THD(N) VERSUS FREQUENCY

The options appear as follows:

Options

Measured THD+N instead of THD

Start Level (dBV)

Stop Level (dBV)

Increment (dB)

Start Frequency (Hz)

Stop Frequency (Hz)

Log Step

Points Per Octave

Hz per Step

Distortion Measurement Stop (Hz)

Plot Right Channel

Graph Title

The output appears as follows:

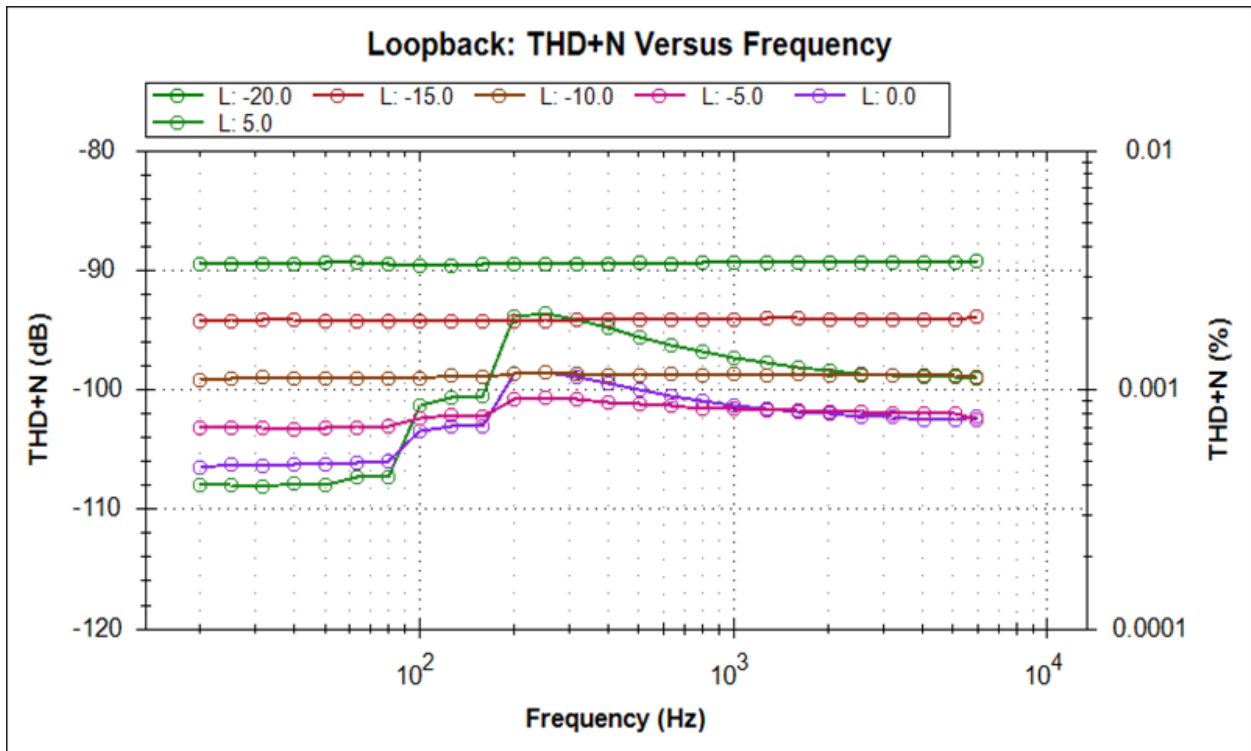

AMP: THD VERSUS OUTPUT LEVEL

The options appear as below:

Options

Measure THD+N instead of THD

Start Level (dBV)

Stop Level (dBV)

Increment (dB)

Test Frequency (Hz)

Distortion Measurement Stop (Hz)

Plot Right Channel

Graph Title

The output appears as below. For this graph, the same measurement at several different FFT sizes was made.

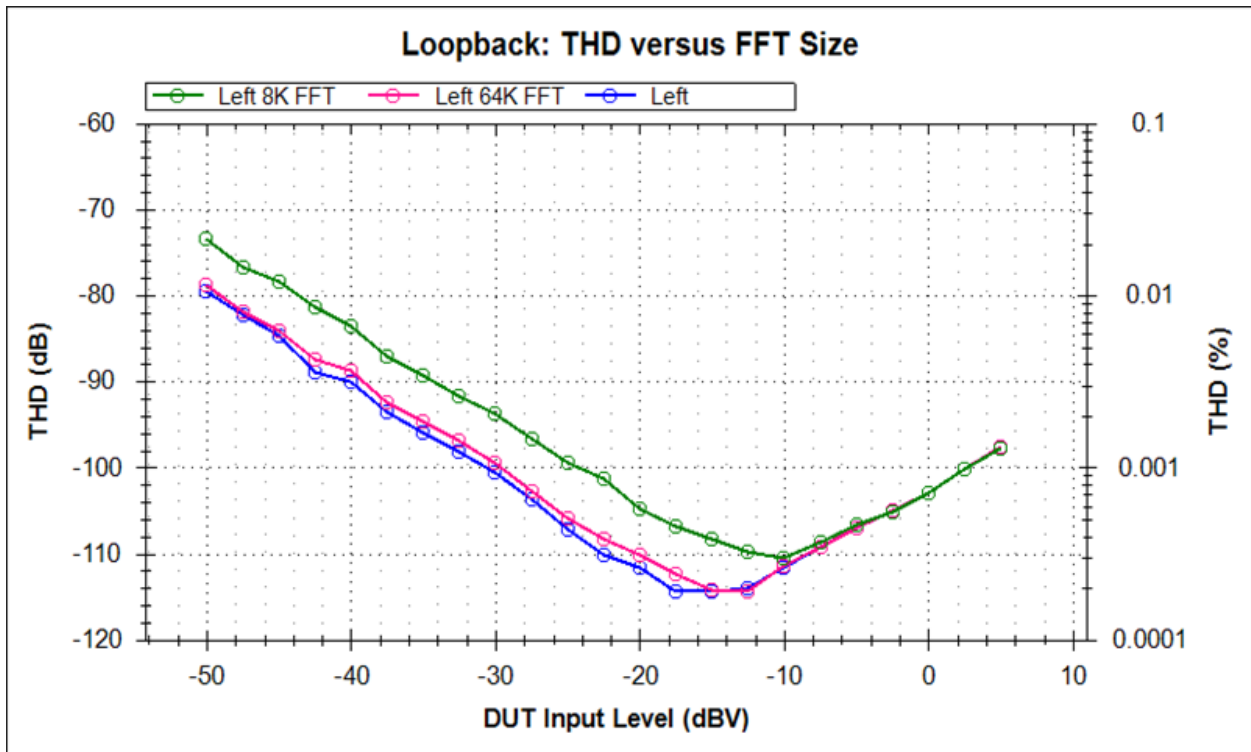

DAC: NOISE AND DISTORTION VERSUS OUTPUT LEVEL

The options appear as follows:

Options

Start Level (dBFS)	<input type="text" value="-60.0"/>
End Level (dBFS)	<input type="text" value="0.0"/>
Increment Level (dB)	<input type="text" value="5.0"/>
Plot Right Channel	<input type="checkbox"/>
Graph Title	<input type="text" value="N+D"/>
Test Frequency (Hz)	<input type="text" value="1000.0"/>
Input dBV corresponding to 0 dBFS	<input type="text" value="6.0"/>
Output dBV corresponding to 0 dBFS	<input type="text" value="6.0"/>

The output appears as follows:

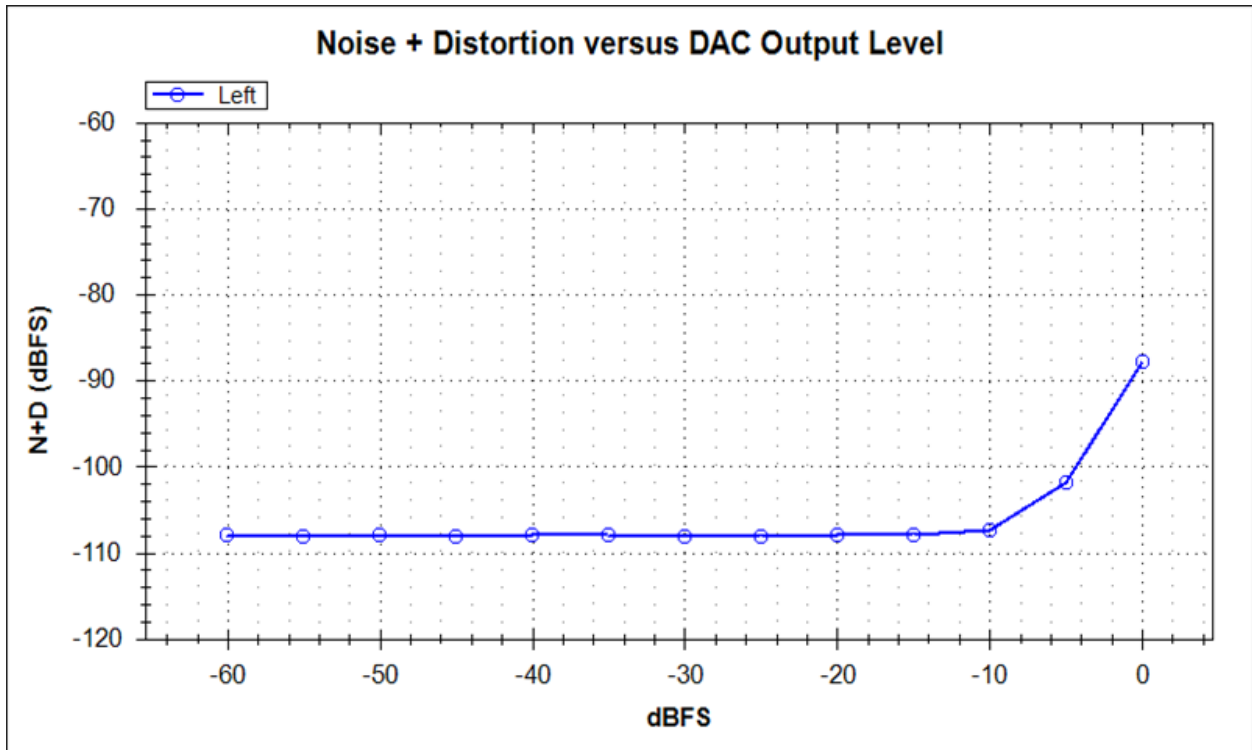

DAC: OUTPUT IMPEDANCE VERSUS FREQUENCY

The options appear as follows:

Options

Output Level (dBFS)

Start Frequency (Hz)

Stop Frequency (Hz)

Log Step

Point Per Octave

Hz per Step

Load Impedance (ohms)

Plot Right Channel

Graph Title

Output dBV corresponding to 0 dBFS

The output appears as follows:

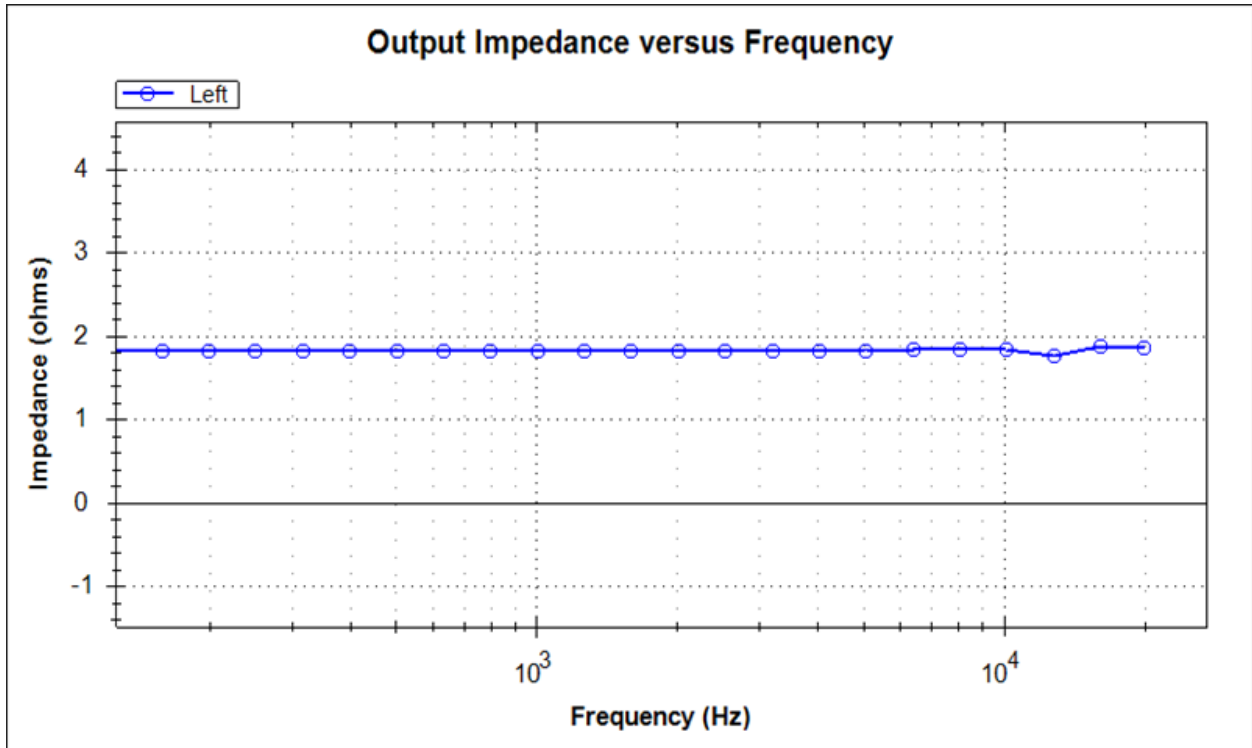

DAC: THD(N) VERSUS OUTPUT LEVEL

The options are as follows:

Options

Measure THD+N instead of THD

Start Level (dBFS)

Stop Level (dBFS)

Increment (dB)

Test Frequency (Hz)

Distortion Measurement Stop (Hz)

Plot Right Channel

Graph Title

The output is as follows:

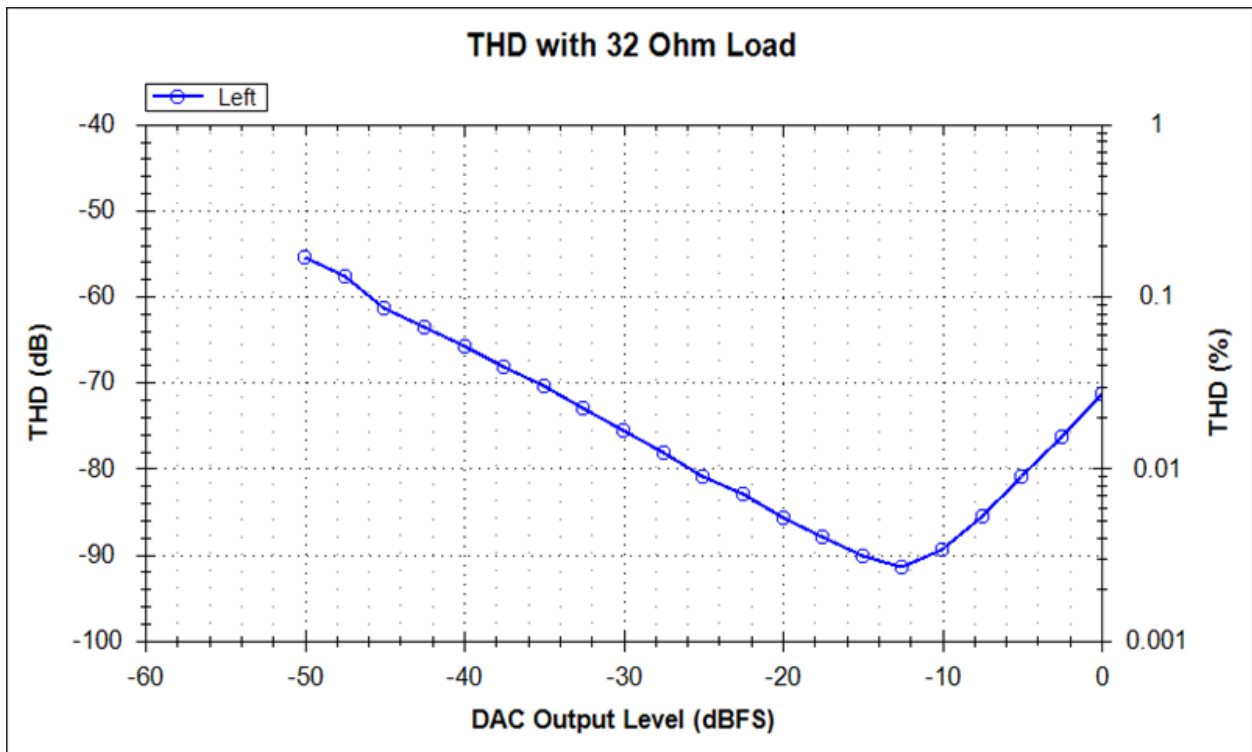

MIC: CompareToReference

This plug-in allows you to compare the response of two microphones—one connected to the left channel and another connected to the right channel. The left channel mic is generally the microphone that has been verified to work in an anechoic chamber by engineering. The right channel is connected to the mic

QuantAsylum QA401 User's Manual

being evaluated (DUT). A difference between the two will be graphed. A mask can be applied to that difference, making it easy to determine on an assembly line if the DUT mic operates as expected.

Generally, you'd want to ensure both microphones are located near each other and then subject both microphones to an identical chirp stimulus from a single speaker.

The settings options for this plug-in appear as follows:

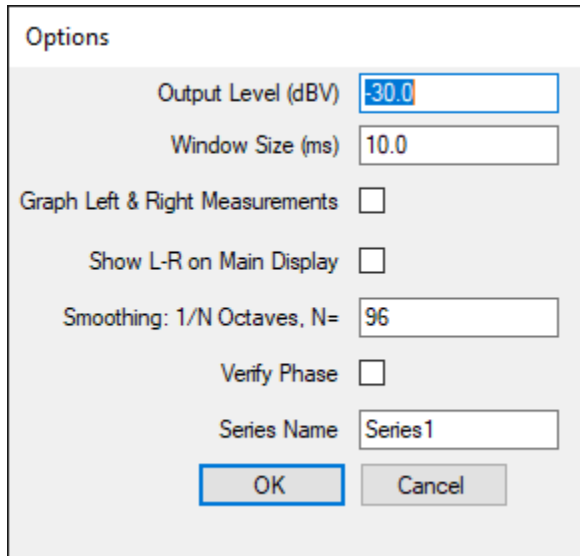

Options

Output Level (dBV)

Window Size (ms)

Graph Left & Right Measurements

Show L-R on Main Display

Smoothing: 1/N Octaves, N=

Verify Phase

Series Name

The Output Level sets the level of the chirp. The Window Size can be set to compensate for reflections in the test setup. In round numbers, if your nearest source of reflection is 3 feet away, then you might specify a window size of 6 ms ($\text{distance}/1000 * 2$). And 5 feet would yield 10 ms. See the section [Frequency Response](#) for more discussion on Window Size.

If you opt to graph left and right measurements, then both the left and right measurements will be displayed on the main screen. The difference between these measurements, which is L-R, will always be displayed. This can be useful if you want to verify the expected sensitivity of the reference mic in the test setup.

Smoothing is specified in terms of 1/octaves. For example, if you wanted 1/12 octave smoothing, then you'd specify the '12' here.

If you opt to verify phase, then a check will be made to ensure the time-domain excursions between the reference and DUT mics are the same. This measurement is made about 1/3 of the way through the chirp, which means the frequency will be well under 1 kHz. If the phase is found to be different between the mics, you'll see a note indicating a problem in the DUT mic.

In the plot below, you can see the inverted phase has been detected and that the reference mic and DUT mic agree with each other within a few dB. This test requires a careful study of your fixturing and the acoustic performance of the area nearby.

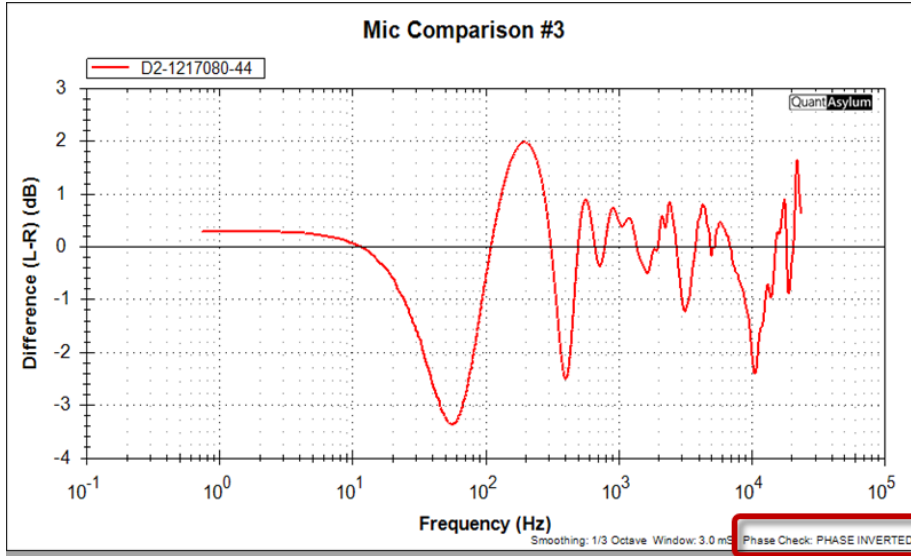

HEAD: Impedance with QA490

The options are as follows:

Options

Output Level (dBV)

Octaves Smoothing, 1 / N, N =

Plot Phase

Plot Right Channel

This plug-in relies on the QA490 hardware to make an impedance measurement of IEMs that are connected to the QA490. The output appears as follows:

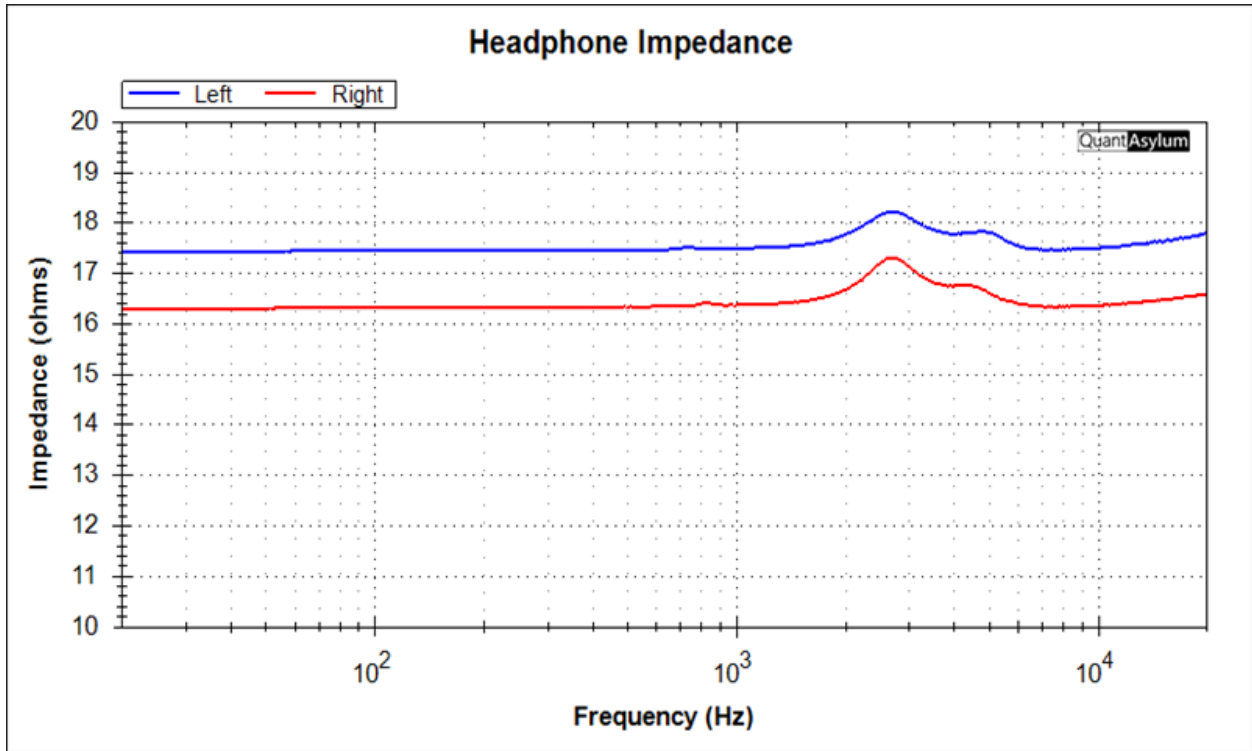

PWR: IMD VERSUS OUTPUT POWER

The options are as follows:

Options

Help

Start Level (dBV)	<input type="text" value="-30.0"/>
Stop Level (dBV)	<input type="text" value="-20.0"/>
Increment (dB)	<input type="text" value="2.0"/>
Load Impedance (ohms)	<input type="text" value="8.0"/>
External Gain (dB)	<input type="text" value="-6.0"/>
Plot Right Channel	<input type="checkbox"/>
Graph Title	<input type="text" value="Title"/>
Trace Name	<input type="text" value="Trace Name"/>
Enable Early Abort	<input type="checkbox"/>
Abort Minimum Power Level (Watts)	<input type="text" value="0.1"/>
Abort Maximum IMD (dB)	<input type="text" value="-80.0"/>

QuantAsylum QA401 User's Manual

The checkbox "Enable Early Abort" is discussed in more detail in the plug-in [below](#).

The output is as follows:

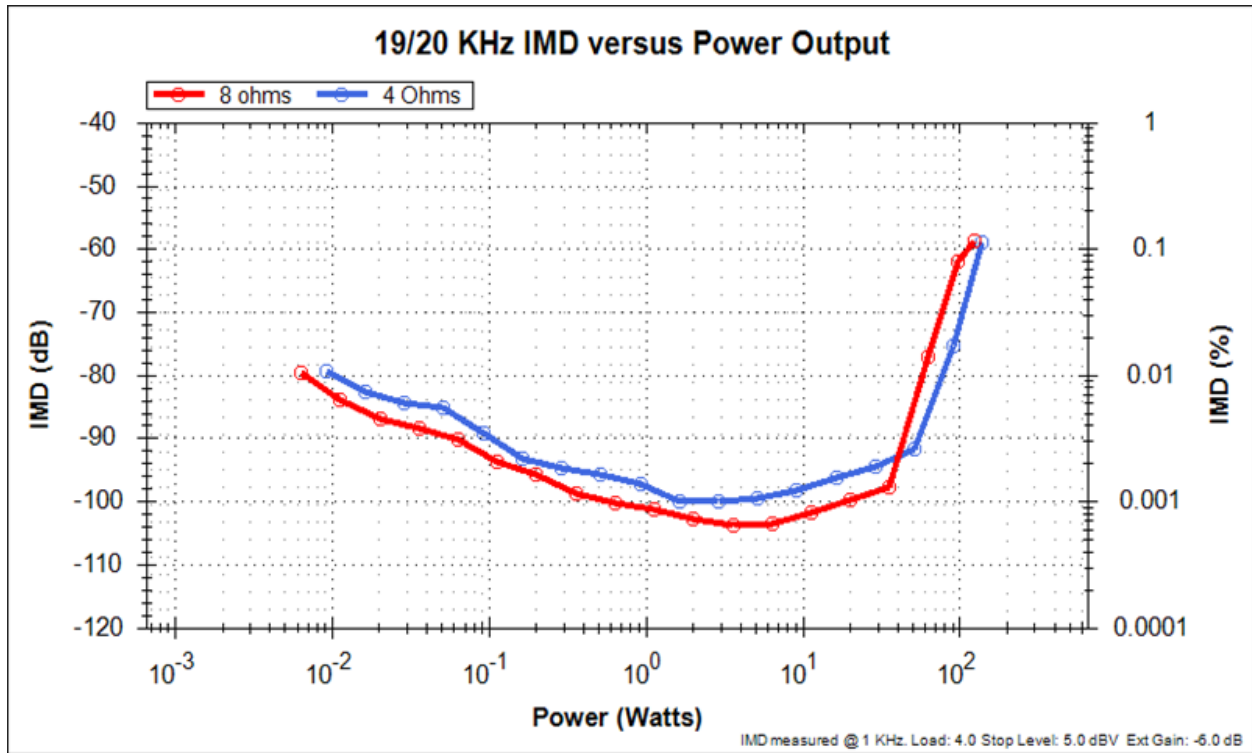

PWR: OUTPUT IMPEDANCE VERSUS FREQUENCY

The options are as follows:

QuantAsylum QA401 User's Manual

Options

Test Level (dBV)	<input type="text" value="-20.0"/>
Start Frequency (Hz)	<input type="text" value="20.0"/>
Stop Frequency (Hz)	<input type="text" value="20000.0"/>
Log Step	<input checked="" type="checkbox"/>
Point Per Octave	<input type="text" value="3"/>
Plot Right Channel	<input type="checkbox"/>
Hz per Step	<input type="text" value="500.0"/>
Load Impedance First Pass (ohms)	<input type="text" value="8.0"/>
Load Impedance Second Pass (ohms)	<input type="text" value="4.0"/>
Graph Title	<input type="text" value="Output Impedance \"/>
<input type="button" value="OK"/> <input type="button" value="Cancel"/>	

The output is as follows:

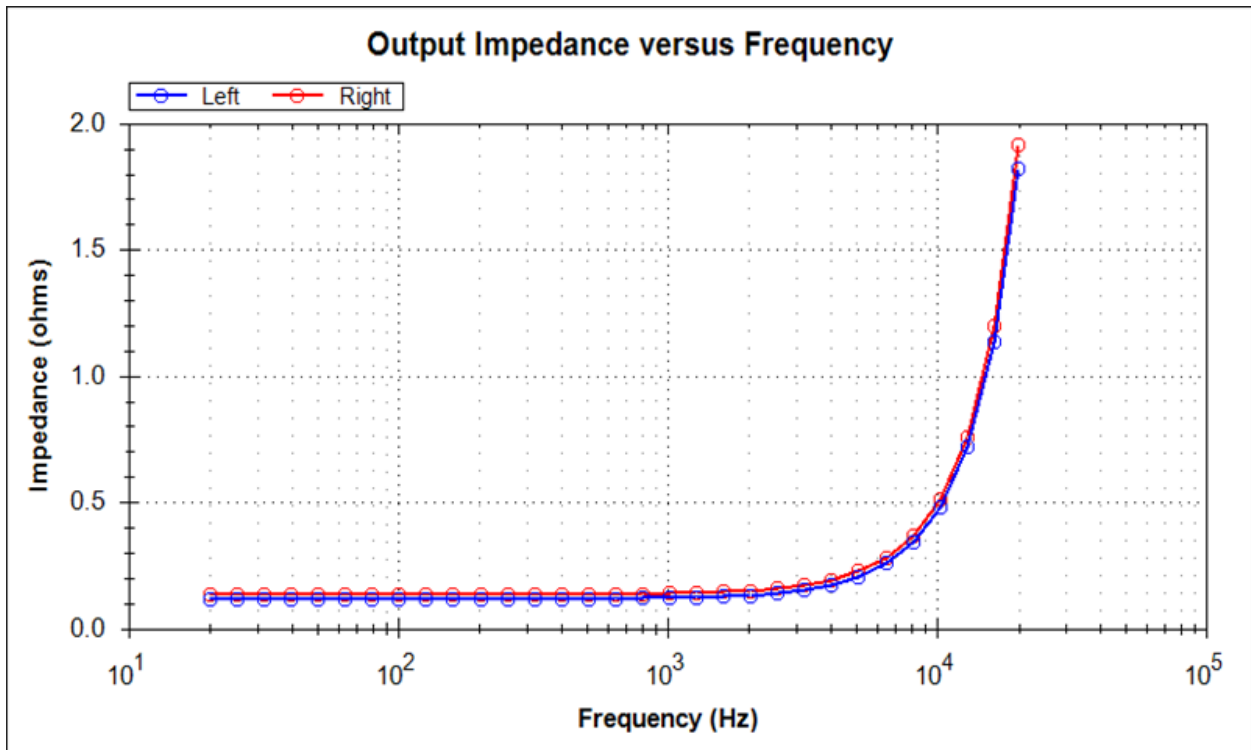

PWR: OUTPUT IMPEDANCE VERSUS FREQUENCY 450

This test is similar to the previous impedance test above, but it assumes a QA450 is connected. The impedance test will complete after automatically switching between four and eight ohms automatically. In the impedance test above, the user must manually change the loads.

The options for this test appear as below:

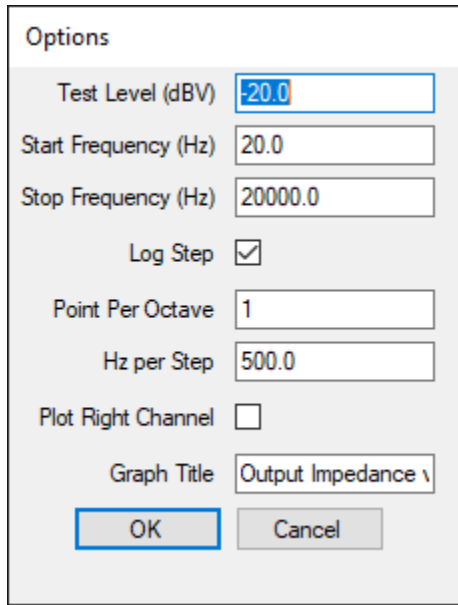

The screenshot shows a dialog box titled "Options" with the following fields and controls:

- Test Level (dBV):
- Start Frequency (Hz):
- Stop Frequency (Hz):
- Log Step:
- Point Per Octave:
- Hz per Step:
- Plot Right Channel:
- Graph Title:
- Buttons: and

PWR: THD VERSUS OUTPUT POWER

The options are as follows:

QuantAsylum QA401 User's Manual

Options

Help

Measure THD+N instead of THD

Start Level (dBV)

Stop Level (dBV)

Increment (dB)

Test Frequency (Hz)

Load Impedance (ohms)

External Gain (dB)

Distortion Measurement Stop (Hz)

Plot Right Channel

Graph Title

Trace Name

Manage Attenuator Automatically

Enable Early Abort

Abort Minimum Power Level (Watts)

Abort Maximum THD (dB)

When you tick “Manage Attenuator Automatically” then the QA401 will always make the first measurement with the attenuator enabled. It will use that measurement to understand the gain and the level into the QA401, and from then on the attenuator will be enabled or disabled based on measured level. For THD+N, you want to leave the attenuator disabled until a few dB below ADC overload. For THD, you want to leave the attenuator disabled until 10-15 dB below ADC overload.

Early Abort will terminate a sequence of measurements early IF the minimum specified power is exceeded AND the maximum specified THD is exceeded.

The output appears as follows:

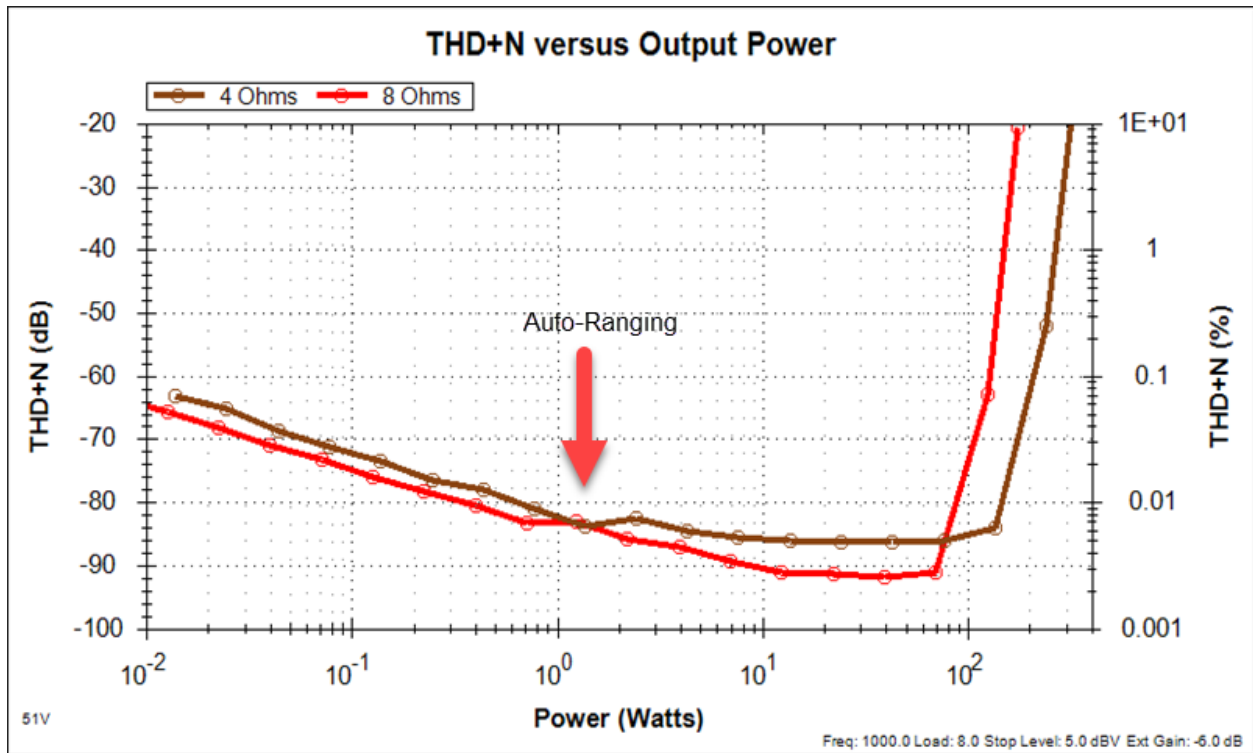

SPKR: CHIRP COMPRESSION

The options appear as follows:

QuantAsylum QA401 User's Manual

Options

Start Level (dBV)	<input type="text" value="-10.0"/>
Stop Level (dBV)	<input type="text" value="0.0"/>
Increment (dB)	<input type="text" value="2.0"/>
Sweep Delay Time (sec)	<input type="text" value="1.0"/>
Octaves Smoothing, 1 / N, N =	<input type="text" value="96"/>
Window Size (ms)	<input type="text" value="10.0"/>
External Input Gain (dB)	<input type="text" value="20.0"/>
Mic Sensitivity (dBV @ 94 dB SPL)	<input type="text" value="-40.0"/>
Mic to Speaker Distance (m)	<input type="text" value="1.0"/>

A chirp specified by the current FFT size will be emitted at increasing levels, ranging from Start Level to Stop Level at the specified increment.

A delay may be specified between bursts. This can be increased to allow reverberations from the chirp to decay before starting the next automated measurement. Without this, very loud chirps in very reverberant rooms might interfere with each other.

The smoothing may be specified. You are specifying the denominator here. So, a value of "48" indicates 1/48th of an octave smoothing is applied. This value will override the value specified in the FR settings.

The [Window Size](#) may be specified. This value will override the value specified in the FR settings.

The plug-in will display sweep amplitude in dB SPL. To accurately plot this, you must specify your microphone's sensitivity. You should also specify any external gain present, such as that provided by a mic preamp.

If the mic-to-speaker distance is > 1, then the displayed output will be increased at 6 dB/doubling in order to refer the output to a 1m measurement. For very large speakers (12" or more), the validity of a measurement at 1m might be a bit uncertain as the speaker will be leaving the near field region and entering the far-field region at 1m. For these large speakers, you might wish to measure at 2m instead.

If you specify 2m for the mic distance, then the displayed output will be increased by 6 dB.

QuantAsylum QA401 User's Manual

A loopback measurement can be made to understand the test in more detail. If you specify a -10 start and stop point, then a single sweep will be made at -10 dBV.

If you have 0 dB of external gain specified and a -40 dBV mic sensitivity, then it will appear that the incoming mic level is 30 dB above the 94 dB SPL point (because -10 dBV is 30 dB above -40 dBV). This should give a displayed value of 124 dB. If you specify a mic distance of 2m, then the graphed value should be 130 dB SPL at 1 kHz.

While still in loopback, if you then ran the plugin and changed the mic gain to 20 dB, then it would appear that the incoming signal was 20 dB weaker than it actually was and the reported value would be 20 dB below the 124 dB measured above.

Be aware that input and output gains specified in the dBV context menu will change the reported results accordingly. That is, you could specify additional mic gain in either the plug-in settings OR the dBV context menu.

SPKR: SPEAKER IMPEDANCE

The options appear as follows:

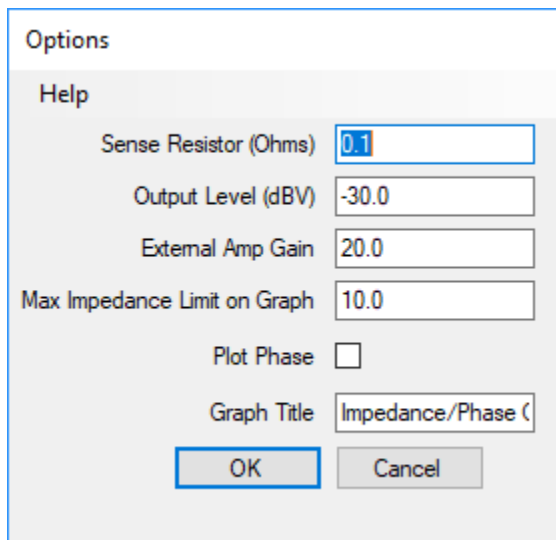

Options	
Help	
Sense Resistor (Ohms)	0.1
Output Level (dBV)	-30.0
External Amp Gain	20.0
Max Impedance Limit on Graph	10.0
Plot Phase	<input type="checkbox"/>
Graph Title	Impedance/Phase (
OK Cancel	

The output appears as follows:

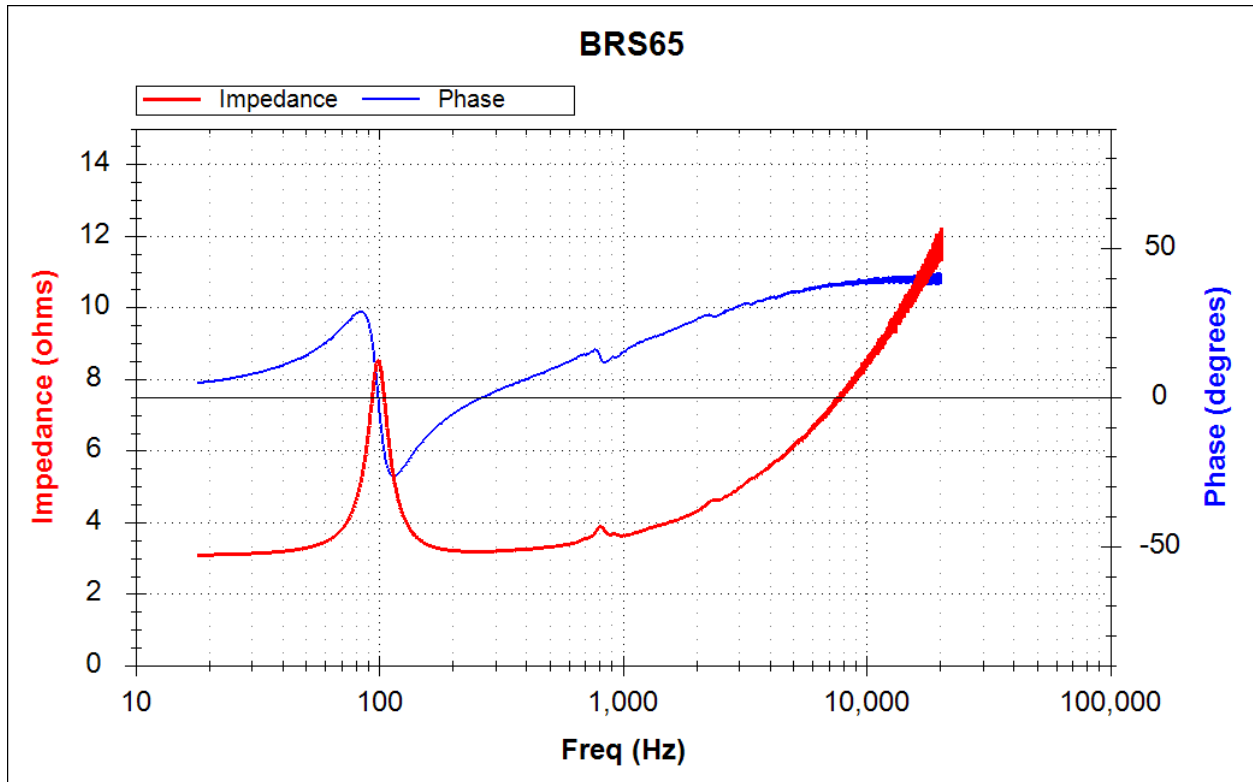

The system setup for measuring speaker impedance must be as shown below:

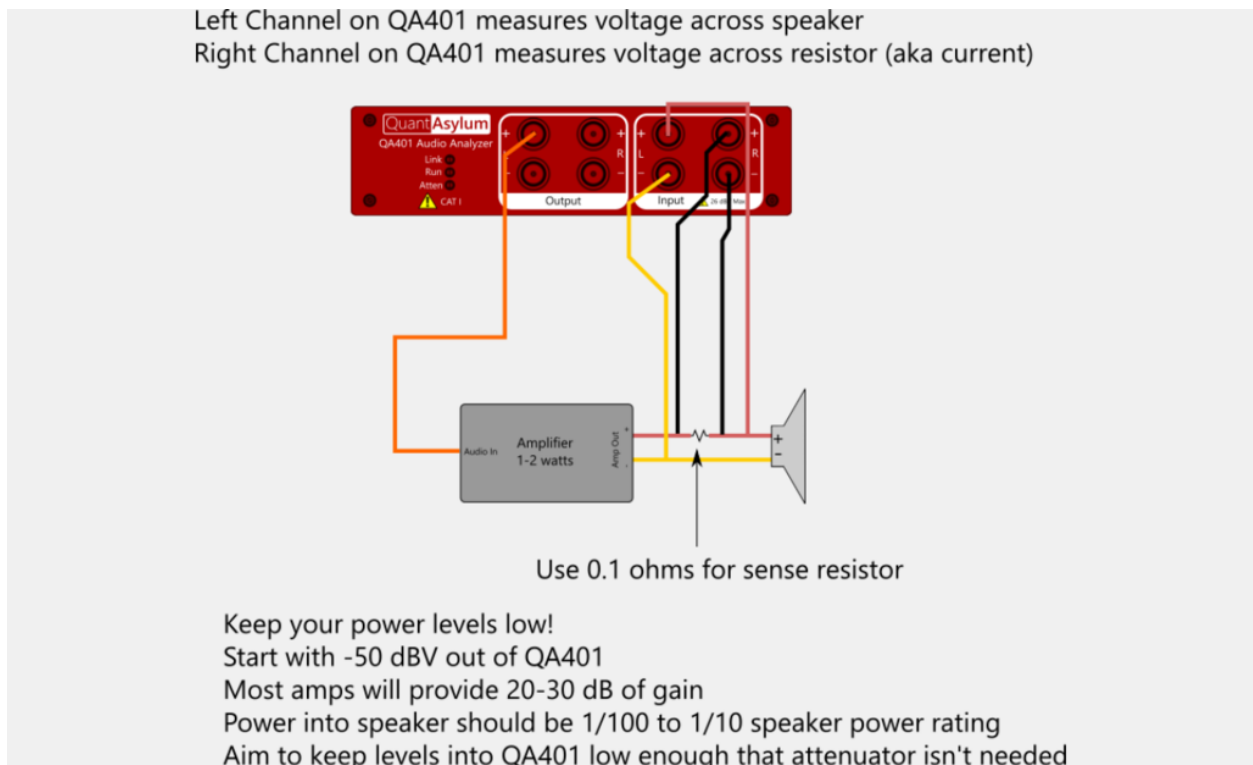

A blog posting going through the process of speaker measurements is located [here](#).

SPRK: Rub and Buzz

The options appear as follows:

Options

Output Level (dBV)

Normalization Frequency

Tracking HPF Multiplier

Mute Left

Mute Right

Series Name

Plot Debug Info

The Rub and Buzz measurement looks at higher order harmonics present in the output from the speaker. The HPF (High Pass Filter) Multiplier specifies the corner frequency of the high-pass filter relative to the current sweep frequency of the chirp. For example, when the HPF Multiplier is set to 10, then when the chirp sweep frequency is passing through 500 Hz, the high pass filter will be set to 5000 Hz, and all energy above 5000 Hz will be reported in the output plot.

A speaker that is functioning correctly will have very little distortion in the regions far beyond the fundamental. A speaker that is suffering from a manufacturing defect will exhibit a lot of energy in this region.

See the blog post [here](#).

Keyboard Shortcuts

The following shortcuts are available to speed certain operations.

The following keys will be useful during your normal work with the analyzer for starting and stopping the analyzer, adding markers, etc. Note that in order for the soft keys to work, the program must have focus. This means that the window is the active window on the desktop. The best way to ensure this is just click at the top of the window and drag it just a bit.

Key	Action
M	This will set a marker at the current peak near the mouse pointer. This can also be achieved by clicking on a peak

QuantAsylum QA401 User's Manual

D	This will delete all visible markers. Deleting an individual marker can also be achieved by clicking on the marker
Space	This is the same as the Run/Stop button. Pressing this will toggle that state.
<CTRL> Space	If currently stopped, this key sequence will run for a single acquisition cycle.
C	Captures the currently displayed analyzer display to the clipboard
L	Captures the left trace and displays it as the Left Snapshot buffer . This is a toggle. Pressing it again will turn off the snapshot display.
R	Captures the right trace and displays it as the Right Snapshot buffer. This is a toggle. Pressing it again will turn off the snapshot display.

Appendix 1: Troubleshooting

This section covers common issues that might be encountered while using the analyzer. In addition to the information here, please also rely on our forum to quick answers to questions you might encounter.

Connectivity Issues

USB, when it works, is a great thing. Plug and Play, when it works, is also a great thing. But figuring out why a USB device isn't working can be a very frustrating experience. The steps below will walk you through all the steps required to figure out why your analyzer isn't working.

Step #1: Make sure you are connected to a high-speed (480Mbps) USB hub

The analyzer requires the additional bandwidth provided by high speed to meet its performance requirements. If you are seeing messages such as shown below, and you are sure you are connected to a 480Mbps hub, then it's possible that another device on the hub is slowing the hub down OR a hub as become stuck at a slower rate. Remove all other devices from the hub and reboot the computer.

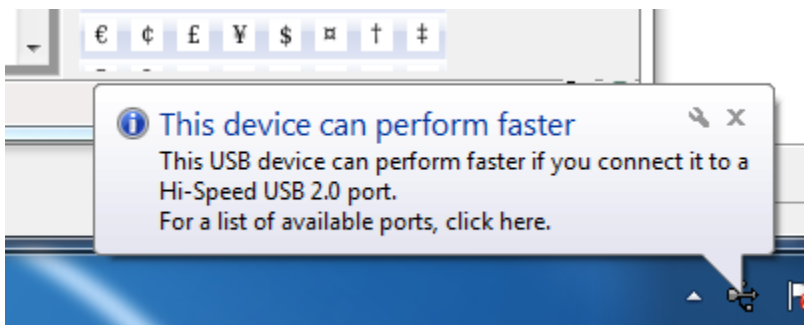

Step #2: Make sure no QuantAsylum applications are running, and then plug in the analyzer and confirm the driver is loading properly.

When you plug in the analyzer, you should hear an audio indication that the analyzer has been plugged in. If you do not, plug in another USB device that is known to work and see if that device gives an audio indication. If it does not, your audio settings might be too low or muted.

With your selected hub able to support high-speed (480Mbps) USB, then next step is to plug in the QA401 device while the application is not running. After plugging in the QA401, check the Device Manager (type devmgmt.msc at the Start -> Run Menu or Start text prompt) and then expand the Universal Serial Bus Controllers section.

This should show a reference to the QA401 Analyzer as highlighted below (although the "development" text might not be present. That is fine).

QuantAsylum QA401 User's Manual

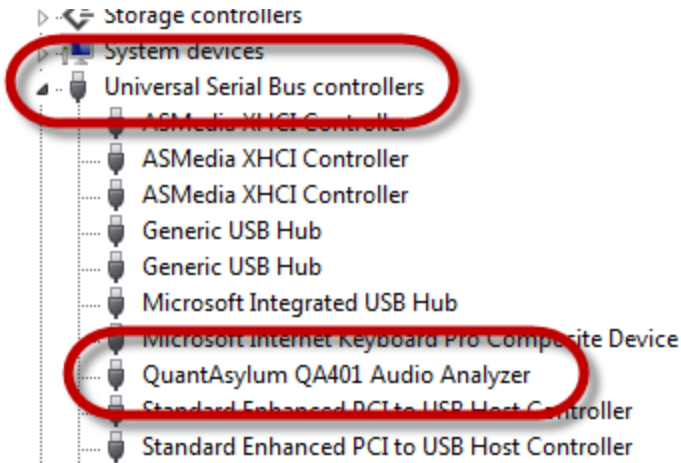

If you see something similar to the above, then the drivers has installed correctly. At this point, you can move to Step #3.

If the driver has not installed, then you might have heard some tones indicating there was an issue, or a message might have popped up explaining the problem.

You should see the device listed in the “other devices” section in the device manager. In this case, right click on the “unkown device” and verify that this in fact the expected device by inspecting the USB ID.

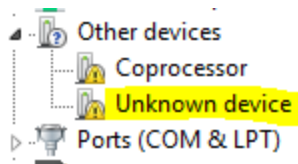

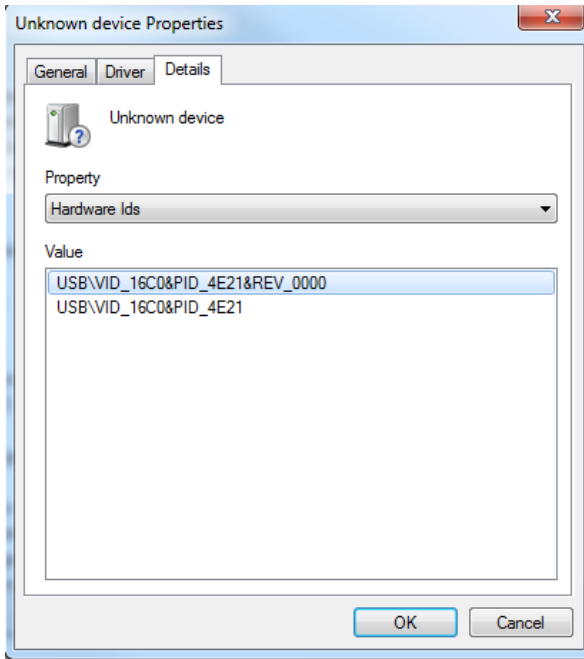

Note you should see the characters “16C0” and “4E22” as shown in the text above. Once you have confirmed this, you can move to manually install the driver. Here, you want to tell Windows to let you pick the driver, and point it to the USB Driver directory of the installed location. At this point, the driver should install itself.

Step #3: Run the application and confirm it can connect

At this point, you have confirmed the drivers have been correctly installed, and you can see the Analyzer appearing in the device manager as shown below.

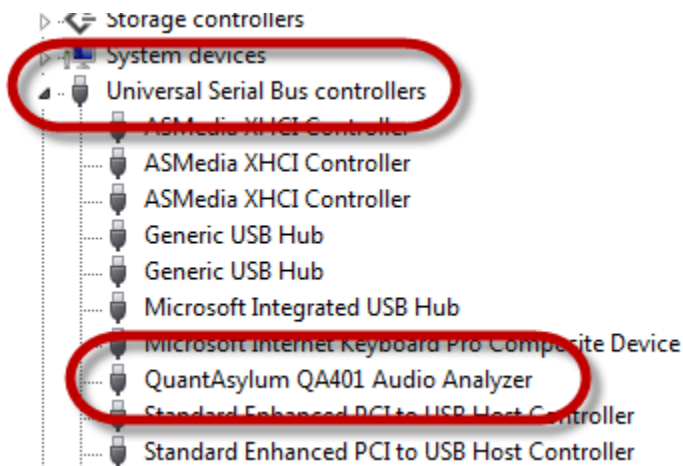

Now, start the QA401 application. You should hear the USB connect indications, followed by an indication from the Analyzer Application that it has connected to the hardware. If this does not occur, unplug and

QuantAsylum QA401 User's Manual

re-plug the QA401. If it still doesn't connect, then re-boot your machine. For problems beyond that, please contact QuantAsylum support.

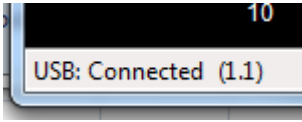

Appendix 2: Visualizers

Content in this section is taken from <http://www.quantasylum.com/content/Home/tabid/40/EntryId/34/Visualizers-and-Examining-the-Residual.aspx>

Please refer to that post on line for more detail.

Background

Visualizers are plug-ins you can write that permit the author access to the acquired data for additional processing. These plugs ins reside in a directory off the main installed directory called “Visualizers”.

When you add a visualizer DLL to that directory, the Visualizer will shows up in the Visualizer menu menu list as shown below.

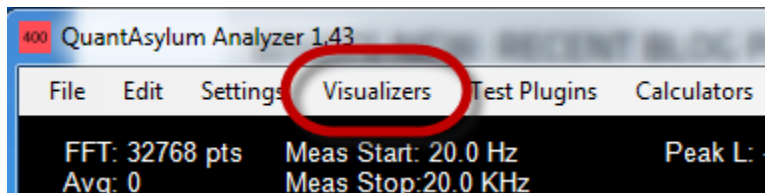

There is a DotNet interface embedded in the QA 401 executable that appears as below:

```
namespace QA400NS
{
    public interface IVisualizer
    {
        string GetMenuName();
        void Start(Form parent);
        bool ShowData(VisSettings settings, double[] dataOutL, double[] dataInL, double[] dataOutR, double[] dataInR);
    }

    public class VisSettings
    {
        public double SampleFreq;
        public double Gen1Freq;
    }
}
```

The visualizer writer must implement three functions:

GetMenuName() is the name of the interface that appears on the visualizer menu drop down.

Start() is called when the interface is first loaded. This allows the visualizer to do whatever it needs to get setup. Usually, this will include creating a dialog box and positioning it as needed.

QuantAsylum QA401 User's Manual

ShowData() is called every time the host acquires a new frame of data.

The basic steps to realize a visualizer are as follows:

- 1) Using Visual Studio, create a new project that is a DLL
- 2) Add a reference to the QA400 application
- 3) In your DLL class, inherit from the QA400NS.IVisualizer
- 4) Implement the required functions. We'll discuss that more below.
- 5) Create and render whatever UI you want

See the post referenced at the start of this section for full code samples.

Appendix 3: Software API

Overview

The QA401 application can be remotely controlled via an external application, making it easy to use the QA401 in an environment where repetitive testing can be automated. The underlying technology used is DotNet Remoting, which is Microsoft's way of allowing applications to communicate with each other in a discoverable and type-safe way over a networking connection. This means the test application and the PC running the QA401 application can be located on the same machine, or they could be located on separate machines across the world. In both cases, the software would be identical.

In the software distribution, there is a file in the API directory called "remotingtest.zip." Unzipping this file will reveal a test application that shows how the remote connectivity is achieved.

The C# interface for the QA401 (version 1.07) is shown below.

```
public interface QA401Interface
{
    /// <summary>
    /// Returns the friendly name of the host hardware. In the case of the QA401, this will be "QuantAsylum QA401 Audio Analyzer" without
    /// quotes. This function will succeed whether or not the hardware is attached to the PC, but the QA401 application must be running
    /// for this to succeed.
    /// </summary>
    /// <returns></returns>
    string GetName();
    /// <summary>
    /// Gets the version number of the software
    /// </summary>
    /// <returns></returns>
    double GetVersion();
    /// <summary>
    /// Returns true if the hardware is connected and functioning.
    /// </summary>
    /// <returns></returns>
    bool IsConnected();
    /// <summary>
    /// Sets the analyzer to a known default state. If fileName is an empty string (which means "", which isn't the same as NULL), then
    /// the internal default is used. Otherwise, the indicated settings file is loaded. If indicated file name was successfully loaded,
    /// then true is returned. If the filename is empty then true is always returned and default is always loaded.
    /// </summary>
    bool SetToDefault(string fileName);
    /// <summary>
    /// This is the same as pressing the RUN button on the front panel when the analyzer is stopped.
    /// </summary>
    void Run();
    /// <summary>
    /// This is the same as pressing the RUN button on the front panel when the analyzer is running.
    /// </summary>
    void Stop();
    /// <summary>
    /// This will set the Generator 1 to active, to an amplitude of amp1, and a frequency of freq1 and then a measurement will be made
    /// with the new generator settings. A single acquisition will be performed. After the acquisition finishes, the analyzer will
    /// automatically stop. The collected data can then be pulled over using the GetData() function. Note that this function only starts
    /// the acquisition. The function will return immediately, and then the acquisition state must be polled via GetAcquisitionState() to
    /// know when the acquisition has finished.
    /// </summary>
    /// <param name="amp1"></param>
    /// <param name="freq1"></param>
    void RunSingle(double amp1, double freq1);
    /// <summary>
    /// Performs a single acquisition with all of the current settings. After the acquisition finishes, the analyzer will
    /// automatically stop. The collected data can then be pulled over using the GetData() function. Note that this function only starts
    /// the acquisition. The function will return immediately, and then the acquisition state must be polled via GetAcquisitionState() to
    /// know when the acquisition has finished.
    /// </summary>
    void RunSingle();
    /// <summary>
    /// Performs a single frequency response sweep.
    /// </summary>
    /// <param name="amp"></param>
    void RunSingleFR(double amp);
    /// <summary>
    /// Returns the state of the analyzer. The state will either be STOPPED or BUSY
    /// </summary>
    /// <returns></returns>
    QA401.AcquisitionState GetAcquisitionState();
    /// <summary>
```

QuantAsylum QA401 User's Manual

```
/// Retrieves the last collected data. If this is called while the analyzer is busy, the result is undefined. The returned data
/// is a PointF array of spectrum data, and each point contains the data amplitude (expressed linearly, and referenced to full
/// scale) and data frequency. Typically, you will want to convert this data into dB.
/// </summary>
/// <param name="channel"></param>
/// <returns></returns>
PointF[] GetData(QA401.ChannelType channel);
/// <summary>
/// Retrieves the last collected time-domain data. If this is called while the analyzer is busy, the result is undefined. The
/// returned data is a PointF array of time data, and each point contains the data amplitude (y value, ranging from -1 to 1) and time
/// </summary>
/// <param name="channel"></param>
/// <returns></returns>
PointF[] GetTimeData(QA401.ChannelType channel);
/// <summary>
/// Given a previous data acquisition, this will compute the power of the provided data. Note the provided data is in linear form,
/// but the returned result is in dB
/// </summary>
/// <param name="data">array for data consisting of linear amplitude and frequency data</param>
/// <returns>Computed power in dB</returns>
double ComputePowerDB(PointF[] data);
/// <summary>
/// Given a previous data acquisition, this will compute the power of the provided data. Note the provided data is in linear form,
/// but the returned result is in dB
/// </summary>
/// <param name="data">array for data consisting of linear amplitude and frequency data</param>
/// <returns>Computed power in dB</returns>
double ComputePowerDB(PointF[] data, double startFreq, double endFreq);
/// <summary>
/// Finds the peak and computes the power in presently selected units. Note the data is presented in linear form, but the result
/// is returned in dB
/// </summary>
/// <param name="data"></param>
/// <returns></returns>
double ComputePeakPowerDB(PointF[] data);
/// <summary>
/// Given a previous data acquisition, this will compute the THD of the provided data. The fundamental parameter specifies the target
/// fundamental, and the max frequency specifies the upper harmonic (in Hertz) that will be considered.
/// </summary>
/// <param name="data">array for data consisting of linear amplitude and frequency data</param>
/// <param name="fundamental">The desired fundamental frequency. The level at this frequency will be suppressed in the calculation,
/// while harmonics of this frequency will be used to determine the THD</param>
/// <param name="maxFreq">Determines the max frequency that will be used for the THD computation</param>
/// <returns>THD level in %</returns>
double ComputeTHDPct(PointF[] data, double fundamental, double maxFreq);
/// <summary>
/// Computes the phase between a reference signal and a second signal and returns the phase between those signals in degrees
/// (-180 to +180). The input signals must be sine waves of the exact same frequency. The expected use of this function is as
/// follows: In situations where you are measuring a DUT using a single sine generated from the GEN1, the output and input time
/// data series can be retrieved using the GetData() call. Once you have the output and input time data, calling this function
/// will compute the phase between these signals. If 'applyCompensation' is true, then the routine will account for internal
/// delays in the QA401. This will ensure that in loopback mode the phase will be reported as 0 degrees for any frequency
/// between 0 Hz and Nyquist.
/// </summary>
/// <param name="reference">The reference waveform</param>
/// <param name="signal">The second signal. If this signal occurs slightly after the reference, this the phase will be indicated
/// as lagging</param>
/// <param name="applyCompensation">If true, then the routine will compensate for delays inside the QA401. If false, the phase
/// calculation will not. The frequency of compensation must be specified if true, otherwise 0 may be used.</param>
/// <returns></returns>
double ComputePhase(PointF[] reference, PointF[] signal, bool applyCompensation, double compensationFreq);
/// Given a previous data acquisition, this will compute the THDN of the provided data. The fundamental parameter specifies the
/// target fundamental, and the max frequency specifies the upper harmonic (in Hertz) that will be considered. As this also contains
/// a noise calculation, the lower frequency bound must also be specified. It is expected that the minFreq less than fundamental which
is
/// less than maxFreq
/// </summary>
/// <param name="data">array for data consisting of linear amplitude and frequency data</param>
/// <param name="fundamental">The desired fundamental frequency. The level at this frequency will be suppressed in the calculation,
/// while harmonics of this frequency will be used to determine the THD</param>
/// <param name="maxFreq">Determines the max frequency that will be used for the noise and THD computation</param>
/// <param name="minFreq">Determines the min frequency for the noise calculation</param>
/// <returns>THD level in %</returns>
double ComputeTHDNPct(PointF[] data, double fundamental, double minFreq, double maxFreq);
/// <summary>
/// Sets the generator to the specified amplitude and frequency. The current units are used.
/// </summary>
/// <param name="gen">Generator 1 or 2</param>
/// <param name="isOn">Sets on/off state</param>
/// <param name="amp">Sets amplitude</param>
/// <param name="freq">Sets frequency. This might be rounded, depending on the host settings</param>
void SetGenerator(QA401.GenType gen, bool isOn, double amp, double freq);
/// <summary>
/// Sets the input and output offsets used in all calculations.
/// </summary>
/// <param name="inputOffsets"></param>
/// <param name="outputOffsets"></param>
void SetOffsets(double inputOffsets, double outputOffsets);
/// <summary>
/// Sets the units for data
/// </summary>
```

QuantAsylum QA401 User's Manual

```
/// <param name="type"></param>
void SetUnits(QA401.UnitsType type);
/// <summary>
/// Sets the length of the in and out sample buffers. The buffer length must be a power of 2 and must be a supported buffer
/// length. If not a power of two, it will be rounded up to the next power of 2.
/// </summary>
/// <param name="samples"></param>
void SetBufferLength(uint samples);

void SetMuting(QA401.Muting muteState);

/// <summary>
/// Generates a continuous tone on the QA401 hardware at the currently selected sample rate. The tone is generated
/// for 'durationMS' milliseconds, and the call blocks during that time
/// </summary>
/// <param name="amp"></param>
/// <param name="freq"></param>
/// <param name="timeMS"></param>
void GenerateTone(double ampDBV, double freq, int durationMS);
}
```

Appendix 4: Regulatory Notice

Overview & Safety

This device is test equipment, designed to be used in a laboratory setting. It is used to examine the signal characteristics of non-lethal voltages in other equipment, powered from low-energy circuits.

It is the responsibility of the user to understand what they are measuring, how it might interact with the test equipment and what voltages might be generated by their measurements.

Environmental

This device is manufactured using RoHS certified parts from leading vendors, assembled in the USA using RoHS certified assembly procedures. The case is powder-coated aluminum. This device should be disposed of as you would dispose a personal computer or any other electronic device in your community.

Power Supply

This device does not operate from line or mains voltage. It is designed to be powered from a low-voltage/low-power USB connection. Maximum internally generated voltages do not exceed 12V in magnitude

Shock Hazard

This device does not pose a shock hazard when used as recommended. This device is not intended to be used for measuring devices that pose a shock hazard. If you measure something that does pose a shock hazard, assume the QA401 will provide little assistance in isolating you from that shock hazard.

FCC

This is a Class A Device (For Commercial Use - Not Residential).

This device complies with part 15 of the FCC Rules. Operation is subject to the following two conditions: (1) This device may not cause harmful interference, and (2) this device must accept any interference received, including interference that may cause undesired operation.

This equipment has been tested and found to comply with the limits for a Class A digital device, pursuant to part 15 of the FCC Rules. These limits are designed to provide reasonable protection against harmful interference when the equipment is operated in a commercial environment. This equipment generates, uses, and can radiate radio frequency energy and, if not installed and used in accordance with the instruction manual, may cause harmful interference to radio communications. Operation of this equipment in a residential area is likely to cause harmful interference in which case the user will be required to correct the interference at his or her own expense.

EU Emissions

WARNING: This is a Class A product. In a domestic environment, this product may cause radio interference, in which case the user may be required to take adequate measures.

QuantAsylum QA401 User's Manual

EU Safety

The QA401 is an Extra Low Voltage (ELV) device per IEC 60038.

EU RoHS Directive 2011/65/EU (RoHS 2), 2015/863 (RoHS 3)

This product is CE marked and complies with the European Union's Directive 2011/65/EU of the European Parliament and of the Council of 8 June 2011 on the restriction of the use of certain hazardous substances in electrical and electronic equipment. EU Directive 2015/863 of 31 March (RoHS 3) amends Annex II to Directive 2011/65/EU of the European Parliament and of the Council as regards the list of restricted substances.

EU Waste Electrical and Electronic Equipment Directive

In accordance with the European WEEE Directive, this device needs to be recycled in accordance with local regulations.

Appendix 5: Specifications

See the QA401 Product Brief located on the QA401 product page on the QuantAsylum web site for the product specifications.