

**57" GRAYSON
CAST IRON
SLIPPER TUB**

Cat. No.
CTSN57



L: 57-3/8"
W: 29-1/2"
H: 22-3/4" & 30" (from floor to top of tub)
16-1/2" & 23-3/4" (from bottom of tub to top of tub)

Water Depth: 13-1/2" to overflow
Water Depth 16-1/2" at drain

Overflow hole: 1 -1/2" diameter

The following is recommended for CTSN57 tubs without deck holes:

- Faucets: part #4602
- Rigid, freestanding supplies: part #4502
- Leg tub drain: part #5599

Gallon Capacity: 35
Shipping Weight: 455 lbs.
Empty Weight: 275 lbs.
Filled Weight: 567 lbs.

Features:

- Inside finish is white enamel
- Cast Iron ball and claw reet available in 6 finishes
- Tub exterior is white (epoxy)
- No faucet holes
- Feet are attached and leveled before shipment
- Tub is thoroughly inspected before shipment

Foot Finishes:

- BP** Polished Brass
- CP** Polished Chrome
- SN** Brushed Nickel
- PN** Polished Nickel
- WH** White
- ORB** Oil-rubbed Bronze



Custom Colors Available (inside of tub is always white enamel):
Painted bathtubs are considered "special order" and are not returnable
\$160 Bisque or Black \$250 Designer Color

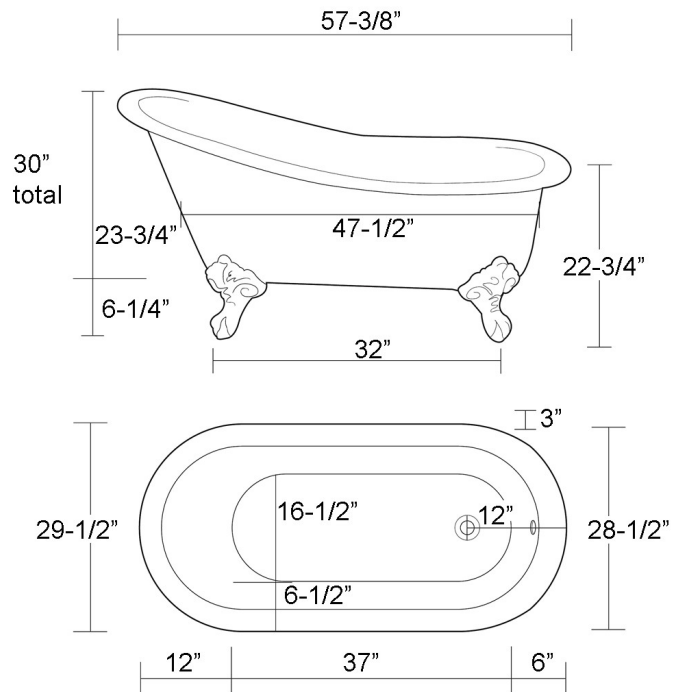

Dimensions of fixture are nominal and may vary within the range of tolerances established by ANSI Standard A112.19.1M. Dimensions and specifications subject to change without notice.