

**72" RANDALL
CAST IRON
DOUBLE SLIPPER TUB**

Cat. No.
CTDSN74B



L: 72"
W: 30"
H: 24-3/4" and 29" (from floor to top of tub)

Water depth: 13-1/2" to overflow

The following is recommended for CTDSN74B tubs:

- Faucet: part #4602, 7393 or 7410
- Rigid, freestanding supplies: part #4502
- Leg tub drain: part #5599E

Gallon Capacity:	53
Shipping Weight:	565 lbs.
Empty Weight:	340 lbs.
Filled Weight:	783 lbs.

Features:

- ▶ Inside finish is white enamel
- ▶ Tub is on cast iron pedestal
- ▶ Tub exterior is white (epoxy)
- ▶ No faucet holes with a continuous rolled rim
- ▶ Tub is thoroughly inspected before shipment



Custom Colors Available (inside of tub is always white enamel):
Painted bathtubs are considered "special order" and are not returnable
\$160 Bisque or Black \$250 Designer Color

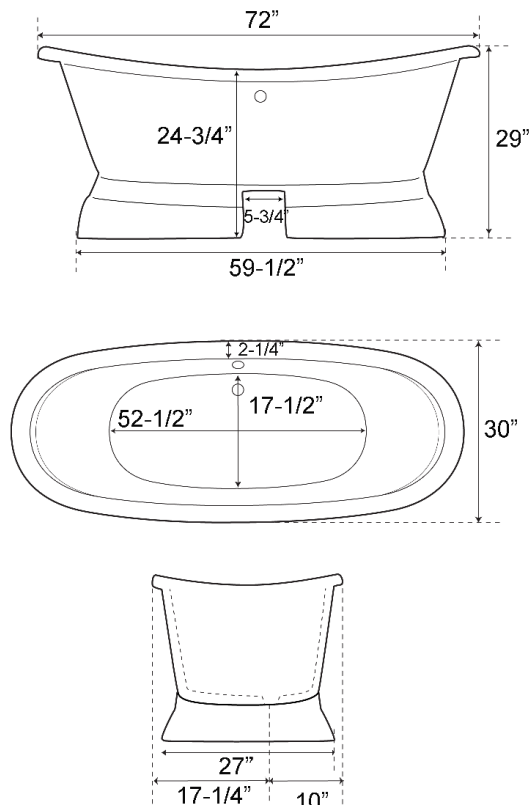

Dimensions of fixture are nominal and may vary within the range of tolerances established by ANSI Standard A112.19.2. Dimensions and specifications subject to change without notice.