

**73" NELSON
CAST IRON DOUBLE
SLIPPER TUB**

Cat. No.
CTDS7H73L



L: 73"
W: 30"
H: 30" (from floor to top of tub)

Water depth: 13-3/4" to overflow

The following is recommended for CTDS7H73L tubs:

- Rim-Mounted Faucet: **#4601 or 7529**
- Straight Bath Supplies: **#5577**
- Leg tub drain: part **#5599**

Gallon Capacity: 57
Shipping Weight: 525 lbs.
Empty Weight: 300 lbs.
Filled Weight: 776 lbs.

Features:

- ▶ Inside finish is white enamel
- ▶ Tub exterior is white (epoxy)
- ▶ 7" Centers in tub deck
- ▶ Pre-drilled overflow hole
- ▶ Built-in adjusters included
- ▶ Solid brass imperial feet available in 4 finishes
- ▶ Feet are attached and leveled before shipment
- ▶ Tub is thoroughly inspected before shipment



Foot Finishes:

BP Polished Brass
SN Brushed Nickel

CP Polished Chrome
ORB Oil-rubbed Bronze

Custom Colors Available (inside of tub is always white enamel):
Painted bathtubs are considered "special order" and are not returnable
\$160 Bisque or Black \$250 Designer Color

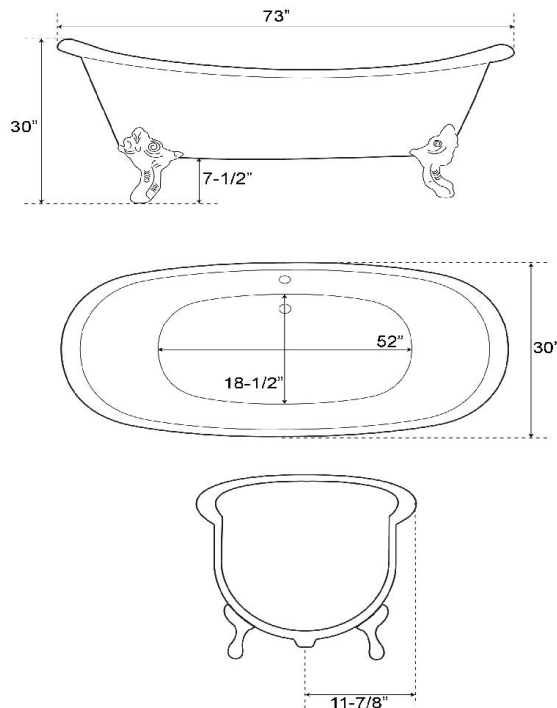

Dimensions of fixture are nominal and may vary within the range of tolerances established by ANSI Standard A112.19.2. Dimensions and specifications subject to change without notice.