

**61" MACON
CAST IRON DOUBLE
SLIPPER TUB**

Cat. No.
CTDS7H61



L: 61"
W: 29-3/4"
H: 29" (from floor to top of tub)

Water depth: 13-1/2" to overflow

The following is recommended for CTDS7H61 tubs:

- Rim-mounted faucet: part #4601 or 7529
- Straight bath supplies: part #5577
- Leg tub drain: part #5599

Gallon Capacity: 30
Shipping Weight: 410 lbs.
Empty Weight: 300 lbs.
Filled Weight: 551 lbs.

Features:

- ▶ Inside finish is white enamel
- ▶ 7" centers in tub deck
- ▶ Pre-drilled overflow hole
- ▶ Tub exterior is white (epoxy)
- ▶ Lion paw feet available in 8 finishes
- ▶ Feet are attached and leveled before shipment
- ▶ Tub is thoroughly inspected before shipment



Foot Finishes:

- BL** Black
- BQ** Bisque
- CP** Polished Chrome
- BN** Brushed Nickel
- ORB** Oil-rubbed Bronze
- PN** Polished Nickel
- PB** Polished Brass
- WH** White

Custom Colors Available (inside of tub is always white enamel):
Painted bathtubs are considered "special order" and are not returnable
\$160 Bisque or Black \$250 Designer Color

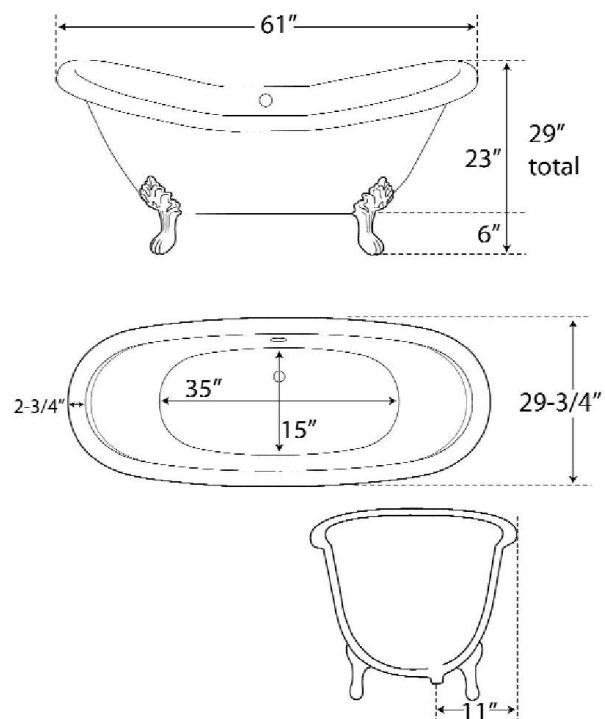

Dimensions of fixture are nominal and may vary within the range of tolerances established by ANSI Standard A112.19.2. Dimensions and specifications subject to change without notice.