

**66" BARNES
COPPER DOUBLE
SLIPPER TUB**

Cat. No.
COTDSN66B-AC



L: 66"
W: 31-1/2"
H: 23 3/4" - 29 1/4"

Water depth: 17-1/2" to top of tub
Water depth: 15" to Optional OF

Features:

- ▶ Constructed of 16 gauge copper
(Copper is a living finish and will patina over time)
- ▶ Hammered antique copper inside and out
- ▶ No faucet holes with continuous rolled rim
- ▶ No overflow
- ▶ Rim is 2-3/4"
- ▶ Hand polished
- ▶ Decorative base is included
- ▶ Hand-crafted construction makes each tub unique

Tub Finishes:

AC Antique Copper

The following is recommended for COTDSN tubs without faucet holes:

- Faucet: **Part #4602, 7393 or 7410**
- Freestanding bath supplies: **Part# 4502**
- Leg tub drain: **Part# 5599LT**



Overflow can be drilled.
With overflow drilled this tub requires drain **5599E**.
Tubs that have been drilled with overflow are "special order" and are not returnable.

Gallon Capacity without OF: 89
Gallon Capacity with OF: 68
Shipping Weight: 260 lbs.
Empty Weight: 150 lbs.
Filled Weight without OF: 895 lbs.
Filled Weight with OF: 718 lbs.

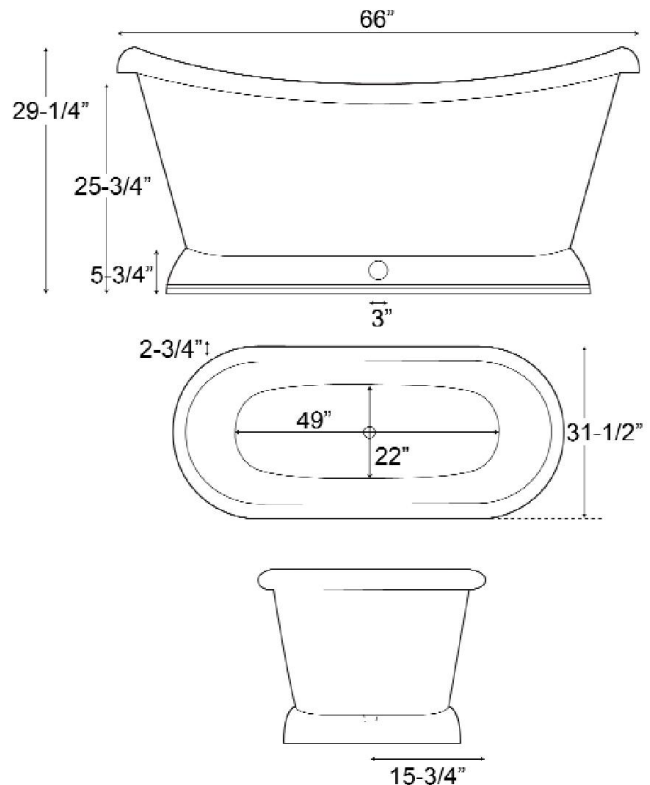

Dimensions and specifications subject to change without notice.