

**CYRANO
44" ACRYLIC
SLIPPER TUB**

Cat. No.
ATSN44



L: 43-1/2"
W: 22-3/4"
H: 21-1/2" - 28"

Water depth: 14-1/2" to top of tub
Water depth: 11-3/4" to OF

Compliance Certification
Meets or exceeds the following specifications: ASME A112.19.2 2013 and CSA B45.1-13 for ceramic plumbing fixtures.

The following is recommended for ATSN tubs:

- Tub wall-mounted faucets: part #4602, 7393 or 7410
- Freestanding bath supplies: part #4502
- Leg tub drain: part #5599LT



Overflow can be drilled .
With overflow drilled this tub requires drain 5599PD.
Tubs that have been drilled with overflow are "special order" and are not returnable.

Gallon Capacity without OF: 21
Gallon Capacity with OF: 17
Shipping Weight: 250 lbs.
Empty Weight: 100 lbs.
Filled Weight without OF: 275 lbs.
Filled Weight with OF: 242 lbs.

Features:

- ▶ Interior and exterior walls acrylic sheets
- ▶ Space between walls partially filled with fiberglass & resin
- ▶ Aluminum ball and claw feet available in 2 finishes
- ▶ No faucet holes
- ▶ No overflow
- ▶ Tub feet are attached and leveled before shipment
- ▶ Tub is thoroughly inspected before shipment

Feet Finishes:

BN Brushed Nickel
CP Polished Chrome



Custom Colors Available (inside of tub is always white enamel):
Painted bathtubs are considered "special order" and are not returnable
\$160 Bisque or Black \$250 Designer Color

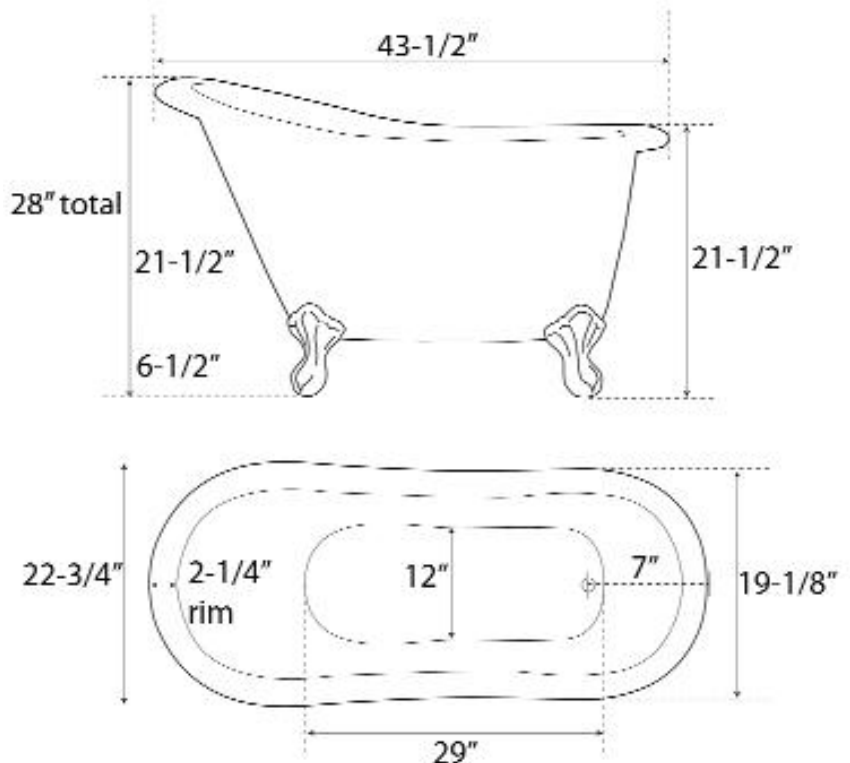

Dimensions of fixture are nominal and specifications subject to change without notice.