

**FOSTER
61" ACRYLIC
SLIPPER TUB**

Cat. No.
ATS7H61LP



L: 61"
W: 27-1/2"
H: 24" - 30-1/2"

Water depth: 14-1/4" to overflow

Compliance Certification
Meets or exceeds the following specifications: ASME A112.19.2 2013 and CSA B45.1-13 for ceramic plumbing fixtures.

The following is recommended for ATS7H tubs:
•Rim-mounted faucets: part #4601 or 7529
•Straight bath supplies: part #5577
•Leg tub drain: part #5599

Gallon Capacity: 39
Shipping Weight: 425 lbs.
Empty Weight: 200 lbs.
Filled Weight: 526 lbs.

Features:

- ▶ Acrylic construction for lighter weight
- ▶ Aluminum lion paw feet available in 4 finishes
- ▶ 7" centers in tub deck
- ▶ Tub feet are attached and leveled before shipment
- ▶ Tub is thoroughly inspected before shipment

Feet Finishes:

- BN** Brushed Nickel
- PB** Polished Brass
- CP** Polished Chrome
- ORB** Oil Rubbed Bronze



Custom Colors Available (inside of tub is always white enamel):
Painted bathtubs are considered "special order" and are not returnable
\$160 Bisque or Black \$250 Designer Color

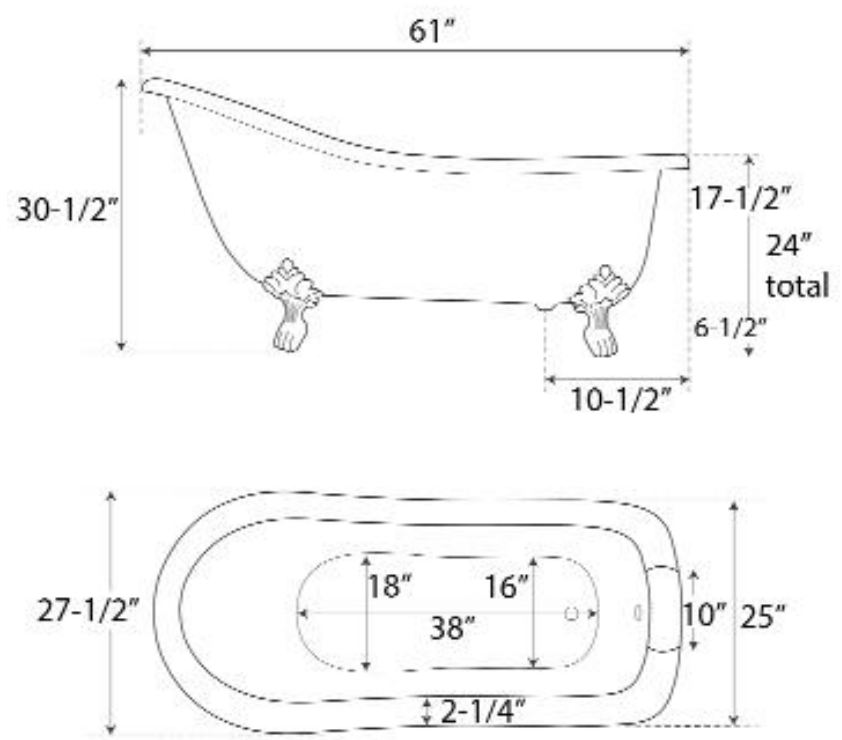

Dimensions of fixture are nominal and specifications subject to change without notice.